



Beef cattle feedlots: design and construction

AUTHORS: Peter J. Watts¹, Rod J. Davis¹, Orla B. Keane¹,
Mairead M. Luttrell¹, Robyn W. Tucker¹, Ross Stafford² and
Scott Janke³

¹ FSA Consulting

² Stafford Adamson and Associates

³ Thompson Longhorn Cattle & Livestock Stockyard Handling

Disclaimer

Care is taken to ensure the accuracy of the information contained in this publication. However, Meat & Livestock Australia cannot accept responsibility for the accuracy or completeness of the information or opinions contained in the publication. You should make your own enquiries before making decisions concerning your interests. Meat & Livestock Australia accept no liability for any losses incurred if you rely solely on this publication. Reproduction in whole or part of this publication is prohibited without prior consent and acknowledgement of Meat & Livestock Australia.

Contact:

Meat & Livestock Australia | Level 1, 40 Mount Street, North Sydney, NSW 2060
Ph: 1800 023 100 | www.mla.com.au

Published by Meat & Livestock Australia Ltd | ABN 39 081 678 364

© Meat & Livestock Australia Ltd, 2015 | ISBN 9781741919165

CONTENTS OF SECTIONS

This manual takes the feedlotter and consultants through the stages of selecting a suitable site, designing the feedlot and its facilities, their construction and the overall management of the project.

In this electronic version, 48 sections are divided into four main subject groups. Each section provides the relevant technical information, and is well illustrated with figures and photographs.

Each section can be selected as required with a click of the computer mouse. High resolution pdfs allow the reader to zoom into any image to investigate detail.

Site selection

1. [Site selection](#)
2. [Site layout](#)
3. [Water supply and sources](#)
4. [Water requirements](#)
5. [Water quality](#)
6. [Energy supply and source](#)
7. [Site investigations](#)
8. [Earthworks](#)

Site design

9. [Overall pen layout](#)
10. [Pen and drainage systems](#)
11. [Sedimentation removal systems](#)
12. [Holding pond design](#)
13. [Access and internal roads](#)
14. [Water reticulation system](#)
15. [Fences, gates and lanes](#)
16. [Shade](#)
17. [Pen and road surfaces](#)
18. [Pen and road stabilisation](#)
19. [Feeding systems](#)
20. [Water trough design and sewer systems](#)

Feedlot facilities

21. [Livestock handling](#)
22. [Receival and dispatch facility](#)
23. [Processing facility](#)
24. [Building over processing facility](#)
25. [Cattle crushes](#)
26. [Office and amenities](#)
27. [Truck weighbridges](#)
28. [Feed preparation and commodity storage](#)
29. [Grain processing equipment](#)
30. [Grain storage and handling](#)
31. [Commodity storage](#)
32. [Silage](#)
33. [Hay storage](#)
34. [Liquid feedstuffs](#)
35. [Feed mixing and delivery](#)
36. [Hospital and recovery pens](#)
37. [Stables](#)
38. [Fuel and gas storage](#)
39. [Chemical storage](#)
40. [Mechanical workshops](#)
41. [Cattle wash facilities](#)
42. [Vehicle wash down](#)
43. [Automatic weather stations](#)
44. [Covered housing systems](#)

Project management

45. [Feedlot construction delivery](#)
46. [Design drawings and technical specifications](#)
47. [Project tendering](#)
48. [Project management](#)



FEEDLOT DESIGN AND CONSTRUCTION

1. Feedlot site selection

AUTHOR: Peter Watts

Introduction

A feedlot must be appropriately sited to ensure its economic viability, environmental sustainability and management performance.

Poor site selection can complicate the approval process and lead to costly licence conditions. It may also significantly increase capital costs (e.g. through excess earthworks or high infrastructure costs) and operating costs through long distances for transporting commodities, livestock or finished cattle.

After a site has been selected, the feedlot layout must be planned. This is the main opportunity to maximise operational efficiency and livestock performance whilst minimising initial capital and ongoing maintenance costs. Plans should also allow for potential expansion.

Design objectives

Feedlot site selection should maximise

- economic efficiency of construction
- cattle health, welfare and performance
- social benefit

while minimising

- ongoing maintenance costs
- any adverse environmental impact

Important issues to be considered include

Regional issues

- prevailing climatic and seasonal conditions
- proximity to major arterial road networks, other feedlots or intensive livestock facilities, abattoirs, saleyards and other services
- available labour
- feedstuffs

Site-specific issues

- suitable topography for construction costs and site drainage
- distance to nearest receptors for odour, dust, noise or visual, aesthetic impact
- distance to nearest potable water supplies (i.e. artesian, reservoirs, water catchment areas)
- legal security of an adequate supply of potable water
- risk of impacts on groundwater
- risk of impacts on surface water quality
- access to construction materials (e.g. clay and gravel)
- absence of archaeological and heritage sites or artefacts
- likely impact on threatened or endangered species or ecological communities
- risk of flood or bushfire
- site access in respect to traffic and road safety
- availability of land and suitability of soil for by-product waste utilisation

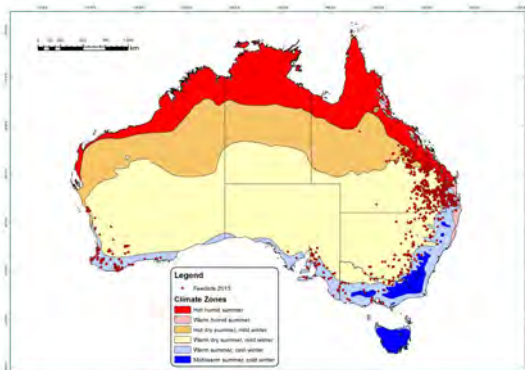

Figure 1. Distribution of feedlots in Australia in relation to climatic zones (2013)

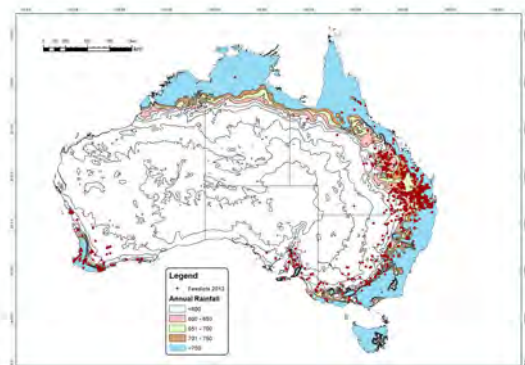

Figure 2. Distribution of feedlots in Australia in relation to mean annual rainfall (2013)

Mandatory requirements

Any feedlot development must comply with relevant Australian Commonwealth, state and local authority codes and regulations (see *National Guidelines for Beef Cattle Feedlots in Australia, MLA 2012*).

Some form of local or regional scale development plan is likely in most states. These plans normally include

- a degree of control on the types of developments allowed
- details of the level of planning and regulatory scrutiny applied
- provision for public comment on significant developments.

While some types of development are excluded in particular areas, most states identify areas where certain types of development such as feedlots are allowed.

However, various Commonwealth and state acts and regulations may influence feedlot site selection where they override local authority planning schemes. Examples include policies associated with

- native vegetation and clearing
- agricultural land conservation
- flora and fauna

All feedlot planning should comply with the *National Guidelines for Beef Cattle Feedlots in Australia (MLA, 2012a)* and with the *National Beef Cattle Feedlot Environmental Code of Practice (MLA, 2012b)*.

Site selection criteria

Climate

Climatic conditions affect both the environmental performance of a feedlot and the welfare and performance of the cattle in the facility. Environmental problems associated with wet conditions include odour, run-off and manure buildup while high summer temperatures with high humidity may result in animal welfare issues.

Sites with a high annual moisture deficit (low rainfall and/or high evaporation rates) are preferable, with an average annual rainfall of less than 750 mm recommended. Figure 2 shows the distribution of feedlots in Australia as related to mean annual rainfall, with most being in areas with less than 750 mm of rainfall. Summer-dominant rainfall is also preferable as pens under with winter-dominant rainfall tend to remain wet throughout the winter months. This can lead to excessive odour, reduced cattle performance and the formation of muddy dags on slaughter cattle. Figure 3 shows the distribution of feedlots in Australia in relation to seasonal rainfall.

Excessive heat load in cattle can be an issue in areas of high temperature and high humidity. Figure 1 shows the distribution of feedlots in relation to climatic zone, with few feedlots in critical areas. Excessive heat load in cattle can be managed through appropriate diet and the provision of shade (see *Section 16 – Shade*).

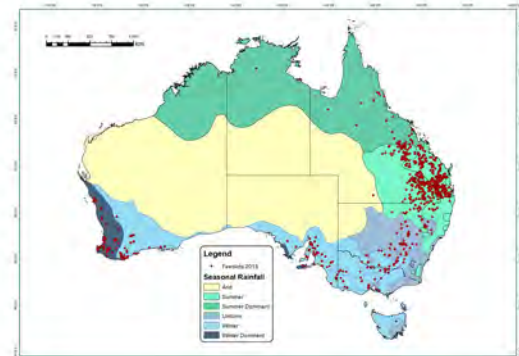

Figure 3. Distribution of feedlots in Australia in relation to seasonal rainfall (2013)



Winter-dominant rainfall with a low evaporation rate can result in wet pens and potential odour nuisance.

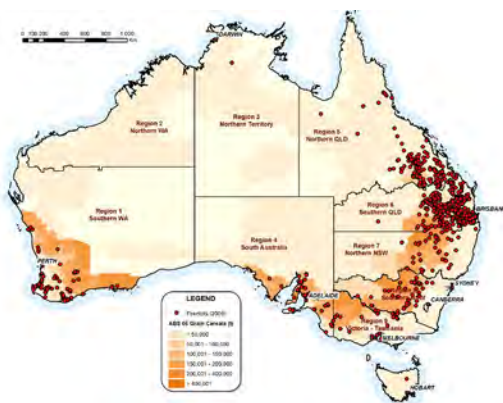

Figure 4. Distribution of feedlots in Australia in relation to grain growing zones (2013)

Access to feedstuffs

Reliability of supply of feed commodities such as grain and roughages (hay, silage) is critical. The existence of other major intensive livestock and industrial users of grain combined with high inter-annual variability in seasonal conditions can affect this reliability, so proximity to major bulk storage and rail facilities can be a worthy consideration. Most feedlots are sited within major grain growing regions as shown in Figure 4. Roughage is also an important component of feed and can be expensive to transport long distances. If the feedlot site is not suitable for producing silage, close access to grain or cotton by-products is important.

Site topography

Sites with a uniform natural slope of two to four percent will help minimise the cost of earthworks by providing the fall required within the drainage system. It will be more difficult (and expensive) to design and implement adequate drainage on a low gradient, but practical feedlot construction can be accomplished with sufficient earthworks.

There should be sufficient depth of soil to accommodate the excavation (cut and fill and borrowing) necessary for earthworks during construction. This applies particularly to areas where sedimentation basins and holding ponds might be located.

Local topography

As feedlot odours drift downhill under still weather conditions it is undesirable to site a feedlot at the top of a confined valley with sensitive receptors below. Sites should be avoided where katabatic drifts can carry offensive odour to receptors. Katabatic drifts can travel many kilometres in the relatively still conditions of early morning or late evening where little or no odour is dispersed.

Native vegetation

Clearing native vegetation can be subject to various regulatory controls. State and local council requirements must be checked before commencing any feedlot development that may involve vegetation clearing. Although clearing may be possible under certain conditions (e.g. with offset plantings), it may be necessary or easier to consider an alternative site. Retention of native vegetation can provide a benefit in minimising the environmental impacts of a new development as well as providing a sensitive and secure visual amenity buffer to the local community.

Sufficient land

Sufficient land is needed for the feedlot complex (pens, cattle handling, feed mill and commodity storage, effluent ponds and manure storage) and should include provision for potential expansion.

A reasonable rule of thumb for the feedlot complex area should be at least three times the pen area. The pen area is the maximum number of cattle multiplied by the stocking density. Hence, a 5000 head feedlot at 15 m²/head requires 7.5 ha of pens and the total feedlot complex would require about 22.5 ha of land. Additional land will almost certainly be needed for effluent irrigation and some solid manure disposal, along with a buffer zone between the development and nearby sensitive receptors.



A natural slope of 2–4% allows for drainage and minimal earthworks for site development. Steeper slopes may encourage erosion.



Local topography may cause fog and odour to drift down a valley undispersed.

Threatened and endangered species

To protect threatened and endangered species, the following potential direct or indirect issues may need to be assessed

- endangered or threatened ecological communities or ecosystems
- critical habitat for endangered or vulnerable species
- wildlife corridors
- wetlands of international, national or state importance (e.g. RAMSAR, High Ecological Significance in Great Barrier Reef catchments)
- migratory species

Some of the above matters are covered by the relevant Commonwealth and state legislation (e.g. the Commonwealth Environment Protection and Biodiversity Conservation Act 1999, the EPBC Act) under bilateral agreements. This means compliance with federal and state legislation can generally be assessed simultaneously by the relevant state agency. In general however, it is not desirable to locate feedlots near National Parks as these are sensitive areas and have frequent visitors.

Water supply

Security of an adequate water supply is vital. A feedlot requires a secure, highly reliable water supply that is correctly licensed, of sufficient capacity and of suitable drinking quality for livestock. That security must be in both a legal (i.e. a legal right to the required volume) and a physical sense (i.e. the physical ability to pump, store and deliver the required volume of water). In areas where water usage is regulated this usually necessitates having an industrial or similar high security water licence, allocation or entitlement. A secondary or emergency water supply is also desirable to enable ongoing supply in the event of a failure of the primary supply.

Water uses at a feedlot include

- drinking water for cattle (and horses)
- dust suppression
- feed processing
- cattle and vehicle wash down
- general cleaning
- landscaping
- staff and office amenities
- dilution of feedlot effluent before application on land.

More information about water requirements for feedlots is provided in *Section 4*.

Protection of water resources

Feedlot developments are required to demonstrate that surface water quality and riverine ecosystems can be protected. In determining water access, developments that alter environmental flow regimes, particularly in regard to the transfer of licences or allocations, should be considered in consultation with the relevant authorities that have regulations and policies to deal with these issues.



Nearby vegetation can provide a visual buffer for a feedlot, but could constrain areas for liquid and solid waste utilisation and limit expansion.



A feedlot site with sufficient land for infrastructure development and for potential expansion.



Security of water, both in quantity and quality, is critical for feedlot development.



Feedlots should be sited outside of the 1 in 100 year flood coverage area and have road access during major flooding.



Geotechnical information of the site is gained by excavating test pits, sampling and analysing the engineering properties of the soil material.

Flooding

Feedlot sites should generally be above a 1 in 100 year average recurrence interval (Q_{100}) flood height. In some cases it might be possible to protect the site using levees or similar structures. However, as levees will affect the hydraulic characteristics of streamflow (in particular flood heights) their installation may not be allowable. Some state and local governments also have guidelines which stipulate that waste utilisation areas need to be above specific flood heights (e.g. Q20 or Q50 floods). These local guidelines should be consulted. Consideration should also be given to all-weather road access during periods of severe flooding.

Geotechnical qualities

It may be possible to use soil and gravel materials available on the site or materials borrowed from sites close by for construction purposes. This particularly applies to clay that might be used as a lining material in feedlot pens, the feedlot drainage and effluent storage systems, composting pads and silage storage bunks. The suitability of soil for earthworks is assessed on the basis of its geotechnical qualities. This is discussed in more detail in *Section 7*.

Manure and effluent utilisation areas

Unless pen runoff can be disposed of totally by evaporation (see *Section 12*), suitable land will be needed for the irrigation of effluent.

Depending on the local demand for manure, suitable land may also be required on the property for spreading the solid manure. The utilisation area(s) should be arable agricultural land with

- soil without any serious limitations on plant growth (such as plant nutrients, available water capacity and structural issues)
- an area large enough to sustainably utilise the nutrients likely to be applied, without risk to surface or sub-surface water supplies
- a climate capable of reliably producing dryland crops, or with reliable access to water for irrigation (expansive waste utilisation areas may be required where it is only possible to undertake dryland cropping).

It may be possible to use land of lesser quality (i.e. land with some significant limitations) but a higher level of management (and monitoring) will generally be required to overcome the constraints. Grazing of effluent disposal areas removes only small quantities of some nutrients such as phosphorus and is therefore generally not a preferred strategy in an effluent disposal program. Additionally, there are withholding periods of up to three weeks before stock graze pastures that have received effluent application, to protect both people and animals from potential pathogen transfer.

Manure and compost may be used off-site, in which case land availability for manure utilisation is of less importance than the availability of land for effluent reuse. Further details on managing the sustainable utilisation of the nutrients in manure and effluent are described in the manual for *Beef cattle feedlots: waste management and utilisation*.

Conservation of agricultural land

State legislation and/or the local authority planning policy may consider the conservation of agricultural land. For example, in Queensland Good Quality Agricultural Land (GQAL) and Strategic Cropping Land (SCL) are agricultural lands that are protected from most non-agricultural developments. While effluent and manure disposal areas should be on arable agricultural land, the converse is true for the actual site of the feedlot complex. When siting a feedlot, consideration should be given to its likely effects on agricultural land conservation.

Salinity and groundwater

The lining of feedlot structures with clay or similar liners will generally result in the feedlot complex posing a minimal risk to landscape salinity or groundwater contamination. The application of feedlot effluent and manure to land may increase soil salinity, especially in low rainfall zones, and this may directly or indirectly increase deep drainage and groundwater recharge. Accordingly, areas that may not be suitable as manure and effluent utilisation areas, or that may require expensive or intensive management and mitigation measures, include the sites with one of more of the following

- shallow water tables or springs
- existing salinity problems
- highly permeable soils.

The guidelines for feedlot developments also recommend a minimum separation distance from bores. The significance of the above is generally higher in areas where seasonal rainfall is frequently higher than soil evaporation (e.g. winter rainfall areas in southern Australia). Where possible, sites with any of these problems should be avoided.

Community amenity

Community amenity is afforded by maintaining the environmental attributes that contribute to physical or material comfort of community members. Nuisance is caused by the unreasonable loss of amenity and can be related to odour, noise, dust and increased traffic associated with the operation of the feedlot on local roads. Central to whether loss of amenity is reasonable or not is the frequency, duration and magnitude of the events that might threaten amenity. A secondary, but important, consideration is the context in which the threat occurs and the prior experience of those being exposed.

Air quality

Feedlots can be a source of fugitive odour and dust emissions. These emissions are termed fugitive since they are not emitted from a readily controlled point (e.g. a duct, vent, chimney or stack) and it is therefore impossible to readily capture or contain them.

Once emitted into the atmosphere, the significance of these fugitive emissions (or the likelihood of their causing a nuisance) is largely dependent on the atmospheric dispersion and dilution that takes place between the source of the emission and the potential receptor. For coarser particulate emissions, such as feedlot dust, some degree



Manure and effluent utilisation area adjacent to a feedlot site.

of settling will take place between the source and the receptor. Vegetation buffers can be useful in diminishing the impact of odour and dust emissions.

The amount of dispersion, dilution and settling after emission is a function of distance – the required distance varying with the prevailing atmospheric stability. Ways of determining the required distance (or distances) include

- fixed separation distances
- odour and particulate dispersion modelling
- variable separation distance formula (where the applicable distance is a function of the scale of the operation, the level of feedlot management applied, the atmospheric conditions commonly experienced at the site and the nature of the surrounding terrain).

Fixed separation distances are typically absolute minimums and may not be considered adequate for larger feedlots. Dispersion modelling and variable separation distance formulas have a more robust scientific basis, but require a substantial body of information to estimate and characterise the emissions. It is often not well suited at an investigatory or preliminary stage. In such cases, the use of variable separation distance formulas can provide a reasonably conservative guide as to what are the likely required separation distances. Separation distance guidelines can be found in Appendix B of the *National Guidelines for Beef Cattle Feedlots in Australia (MLA, 2012a)*.

Noise

Ambient noise levels in rural areas are usually low (<30 dB), particularly at night. As a consequence any new, unusual or particularly loud noise is likely to be noticed, measurable and therefore have some potential to cause a nuisance – more so than if the same noise was to occur in a busy urban environment.

Factors affecting the amount of noise reaching a receptor include the

- nature of the surrounding terrain
- vegetative state of the buffer zone or surrounding terrain
- atmospheric conditions
- frequency and tonal qualities of the noise.

In beef cattle feedlots, common sources of noise emissions include

- stock handling activities (such as loading, unloading, moving, drafting)
- vehicle movements (including feed trucks, trucks delivering commodities and livestock transport trucks)
- feed milling and handling
- other plant and equipment.

For the ‘normal’ noise emissions from the feedlot complex, the separation distances typically required to mitigate air quality impacts will usually afford protection from noise impacts at these same receptors. Exceptions to this may include

- less common or intermittent noises (e.g. noise from construction activities)
- frequent or unusual nighttime activities (e.g. night-time milling and mixing of feed, livestock deliveries)
- traffic noise along roadways servicing the feedlot.

Confining noisier activities to daytime and, where unavoidable, evenings, will normally minimise the risk of adverse noise impacts. However, in instances such as the loading or unloading of cattle in summer (particularly where daylight saving applies) animal welfare considerations may preclude confining operations to such times. The design capacity of the feed mill and mixing facilities could be such as to avoid routine operation at night. Selective use of access routes to the feedlot can reduce specific off-site noise issues.

Visual amenity

In designing and siting a feedlot, due consideration should be given to its visual impact. Advantage should be taken of any natural screening provided by topography or vegetation. Highly visible sites should be avoided. Where a site is visible, buffers of trees or earth mounds can be developed between the site and nearby vantage points.

As with noise complaints, the separation distances required to address air quality impacts often provide for significant mitigation of visual impacts at nearby residences or townships, particularly in low-relief terrain. The ongoing maintenance and management of the feedlot and its associated infrastructure in a clean and tidy condition will generally assist the positive visual impact of the facility.

Roads and traffic

When selecting a feedlot site, the following impacts of traffic should be considered

- local road network
- internal road infrastructure
- traffic noise
- road safety.

Local and state governments generally have criteria by which they judge the significance of an impact on the road network. Typically these will involve a threshold increase in road traffic volumes or pavement loads that correspond to what would otherwise be expected with the 'normal' growth in the Australian economy (e.g. the average percent increase in national GDP).

National and state standards apply to road design in Australia. These standards cover a diverse range of matters, not the least of which is road safety. Owing to the volume of heavy transport they can generate, feedlot developments may require the upgrading of roads and bridges to comply with the standards. Common requirements include the need for all-weather access and the upgrading of turnoffs and road junctions servicing a development. Such upgrading work may particularly apply on major roads where the higher traffic volumes trigger the need to install slip and turning lanes. The feedlot may be required to contribute some or all of the cost of any upgrading work necessary.

Owing to low ambient noise levels in rural areas (particularly at night), traffic noise may require specific consideration. In such cases, noise-related conditions such as curfews on traffic movements or having designated access routes may be applied.

Consideration should also be given to enabling access to the facility by B-double, B-triple and road train transport where applicable. This will reduce the ongoing operating costs of the feedlot.

Proponents are encouraged to consult with the responsible authority early in the planning stages to identify any standards and road requirements, identify whether the proposal needs to be referred to a roads authority and the arrangements for upgrading public roads.

Mining leases

Searches should be undertaken to ensure that the proposed feedlot will not be located on an existing or possible future mining or gas lease.

Archaeological and heritage issues

Impacts on Aboriginal, European and natural heritage need to be considered during the assessment process for a feedlot development. Most state governments maintain registers of known sites and these should be consulted before selecting a development site. Notwithstanding the status of a property in these registers, it is still possible that a detailed site assessment will be required before gaining development approval or consent. Proponents are encouraged to consult with the responsible authority early in the planning stages to identify any requirements. The selection of sites with no heritage issues is an advantage.

Local plans or planning schemes

These plans are normally made and administered by a local government authority (e.g. a shire or local council). Typically these local plans establish zones or similarly designated areas where certain types of development are allowable after some relatively basic considerations. Other developments may require more intensive scrutiny and consideration (i.e. impact assessment).

Where local government areas encompass rural areas, there will normally be rural or agricultural zoning which allows most traditional agricultural activities (e.g. cropping or grazing) to take place with few, if any, approval requirements. Often, feedlot developments are allowable in these rural areas or zones after some form of impact assessment. However, in some cases (e.g. in a rural zone where the dominant land use is horticultural, such as orchards or vineyards frequented by tourists), a feedlot development may be a prohibited development (i.e. not allowable even with impact assessment).

Copies of local plans are usually available for perusal or purchase at the offices of local government authorities. Increasingly, these documents are freely available on the Internet. It should also be noted that these plans are subject to frequent revision, and the fact that a previous development was allowed does not mean a new one will be permitted.

Regional plans

Regional plans are normally a 'big picture' version of local plans. They are an increasing common strategic planning instrument, particularly where sensitive areas such as riverine wetlands overlap a number of local government areas.

It is common for local plans to be drafted to accommodate the requirements of any regional plan, and consequently compliance with a local plan will provide compliance with the regional plan. Nevertheless, some local plans predate regional ones and there may be some specific requirements, additional to those of the local plan, which need to be addressed. Local government planning departments can provide advice on these matters.

Catchment management plans

In some states, catchment management plans have a formal status in legislation and regulation. Like regional plans, catchment management plans usually cover a number of local government areas and their requirements may already be reflected in the respective local government plans. However, catchment management plans are generally a newer form of planning and their requirements may not always be addressed by local plans. Checking whether a catchment management plan exists and what is its official status is recommended to anyone considering developing a feedlot. For example in Queensland and Victoria, feedlots are excluded from Declared Catchment Areas which are the areas immediately surrounding municipal water supply dams.

Access to building materials

Consideration should be given to the on-site availability or nearby off-site access to the following

- suitable clay for lining of feedlot pens, drains, effluent holding ponds, manure storage and composting pads
- suitable gravel for construction and maintenance of feedlot pens, drains, composting pads, roads, cattle lanes and hard stand areas
- suitable materials for road base and sub-grade
- concrete aggregate (if mixing on-site) or ready-mixed concrete.

Clay pits and quarries for even moderately sized feedlots may themselves require a development approval and licence and as a result, an environmental impact assessment or similar report.

Labour availability

Feedlots can have a significant requirement for labour – about one person for every 750 to 1000 head of capacity. In larger operations where these requirements cannot be met by family or staff residing on-site, proximity to towns, villages or a nearby source of potential employees may be a significant consideration in determining the scale and location of the proposed development. Consideration may also need to be given to the provision of on-site accommodation if the feedlot is located some distance from major residential areas.

Electricity

Most feedlots require reliable, 3-phase power. Due to the cost of installing overhead supply it is desirable to locate a new feedlot where 3-phase power already exists.

Development staging

The staging of feedlot developments is quite common. Staging a development can help establish that

- predicted impacts of the final development are reliable
- impacts are capable of being properly managed
- success in managing the impacts can be reliably monitored.

This can be advantageous to both the developer and the regulatory agencies.

Further reading

Guidelines for the establishment and operation of cattle feedlots in South Australia, Department of Primary Industries and Resources (SA) and Environment Protection Authority, 2006, Adelaide.

Guidelines for the Environmental Management of Beef Cattle Feedlots in Western Australia, Bulletin 4550, 2002, WADo Agriculture (ed.), Western Australia Department of Agriculture, Perth, WA.

National Guidelines for Beef Cattle Feedlots in Australia – 3rd Edition, Feedlot Industry Accreditation Committee (ed.), June 2012, Meat & Livestock Australia, Sydney, NSW.

National Beef Cattle Feedlot Environmental Code of Practice – 2nd Edition, Feedlot Industry Accreditation Committee (ed.), June 2012, Meat & Livestock Australia, Sydney, NSW.

Skerman, A 2000, *Reference manual for the establishment and operation of beef cattle feedlots in Queensland*, Information Series QI99070, Queensland Cattle Feedlot Advisory Committee (FLAC), Department of Primary Industries, Toowoomba, QLD.

The New South Wales feedlot manual, 1997, NSW Agriculture, NSW Agriculture, Department of Land and Water Conservation, Department of Urban Affairs and Planning & Environment Protection Authority, Orange.

Victorian code for cattle feedlots, August 1995, Victorian Feedlot Committee, Department of Agriculture, Energy & Minerals, Melbourne.

Commonwealth of Australia 1999, Environment Protection and Biodiversity Conservation Act 1999 (the EPBC Act).



FEEDLOT DESIGN AND CONSTRUCTION

2. Feedlot site layout

AUTHOR: Peter Watts

Introduction

The principal objective of lot feeding cattle is to profitably produce beef of a specific, predictable and consistently repeatable quality for particular markets, both locally and overseas. Profitability is determined by

- cattle performance and meat quality
- the feedlot's
 - capital cost
 - operating cost
 - maintenance cost

However, the successful performance of a feedlot is now also measured by community acceptance. Thus it has to meet acceptable standards of

- environmental impact
- animal welfare
- community amenity
- workplace health and safety.

To meet these performance criteria, a feedlot must adopt a quality assurance program covering site selection, design, management and monitoring.

A feedlot is a production system incorporating several components that need to be carefully integrated. An overview of the various system components is given below. Detailed descriptions of the various components of a feedlot system are given in other sections.

This section describes the design of the overall layout of a feedlot to meet the profitability and community acceptance performance criteria.

Operational costs, including those of energy, have increased sharply in recent years while the availability of labour has declined.

Good site layout will integrate these components. If the layout is not ideal, components of the system can interfere, leading to operational inefficiencies.

Components of a feedlot system

Feeding system

Feed delivery, feed storage, silage pits, hay storage, feed processing mill, feed mixing/batching, feed trucks, feed alleys and feed bunks.

Watering system

Water source, pumps and mainlines, emergency storage, pen reticulation system, water troughs and sewer system.

Cattle handling system

Receival and induction facility, holding pens, cattle lanes, feeding pens, hospital pens, recovery pens and dispatch facilities.



Feeding system – storage, processing and delivery

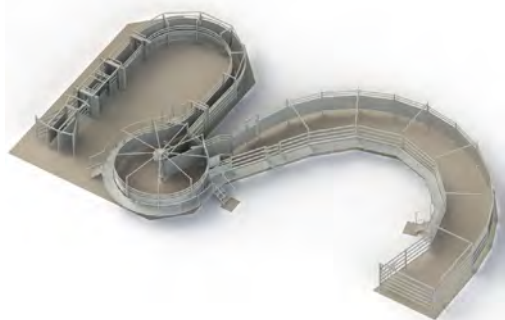

Cattle handling systems – receival and induction, feeding pens and lanes

Drainage system

Feeding pens, pen drains, main drains, sedimentation systems, holding ponds and effluent utilisation areas.

Manure handling system

Stockpile and manure screening area, pen manure cleaning equipment, manure composting and equipment, manure transport and processing equipment and manure utilisation areas.

Employee and visitor facilities

Offices, amenities, lunch rooms, car parks, horse stables and workplace health and safety facilities.

Maintenance facilities

Infrastructure for engineering, maintenance and repairs to equipment.

Security system

Perimeter fencing, gates, lighting, signage and security cameras to provide biosecurity and security to the site.

Design objectives

The design objectives for a feedlot site layout are to

- maximise operational efficiency
- maximise cattle performance
- minimise environmental impact
- minimise waste
- maximise workplace health and safety
- maximise cattle welfare
- minimise capital and operational costs.

Specific design issues for consideration

- Minimise travel distances and times for cattle, feed trucks and manure equipment within the feedlot system.
- Roads, drains and cattle lanes should not cross or traverse, and there should be no gates in the feed alley or road network system.
- Separate cattle lanes and drains are preferable. When using a single cattle lane/pen drain it may be difficult to get cattle to walk through a wet and muddy drain and cattle may also bog-up the drain, reducing its effectiveness. Using the drain for the access of manure cleaning equipment can further damage it. (See Sections 10 and 16.)
- Avoid narrow cattle lanes, gateways, tight corners and turning circles to ensure efficient movement of cattle, feed trucks and manure cleaning equipment.
- Avoid narrow gates. The use of 'herringbone' type gates in cattle lanes enables excellent cattle flow in and out of the feeding pens while increasing turning circles for vehicle entry and exit. A single gate and a fixed opposing panel are adequate if cattle and manure equipment always move in one direction, but two gates are required if movement in both directions in the lane is envisaged. (See Section 16 – Fences, gates and lanes.)



Manure handling system – pen cleaning, manure composting and utilisation

Consider Intersection Design Looking at Number of Conflict Points

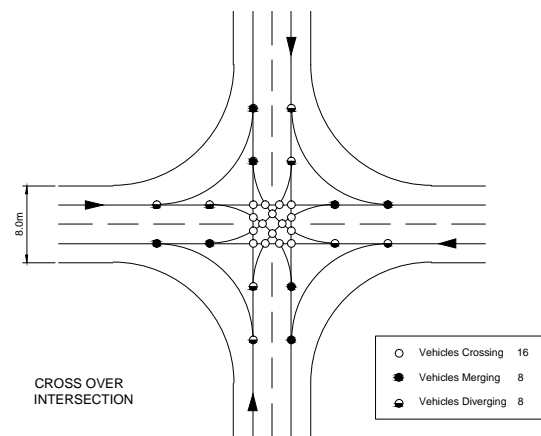

Access road intersections



Wide lanes and gates



Avoid drainage within or between pens.

- Orientate feeding pens to optimise the effectiveness of shade structures (if required).
- Avoid feed bunks and water troughs interfering with pen drainage.
- Avoid a pen layout that results in pen-to-pen drainage.
- Contain and collect all drainage from manure-affected areas. The receipt and dispatch facilities, feeding pens, hospital pens and manure stockpile (and ideally silage storage) should be located within the controlled drainage area.
- Minimise the size of the controlled drainage area to reduce runoff volumes, pond sizes and the areas required for effluent utilisation. With a compact but workable layout, the controlled drainage area should be no more than two to three times the pen area. If larger with three to four times the pen area, revise the layout or select a different site.
- Stables should be provided for horses used in pen riding and mustering on larger feedlots and are best located near the livestock handling yards. Facilities for horse feed and tack should also be considered.
- All vehicles should enter and exit the facility passing a single point or an office to maintain security. This is often a convenient site for a weighbridge. A security fence should encompass the whole site to keep stray stock in or out of the feedlot, while enhancing security.
- Layout should maximise buffers between the feedlot and the public or neighbours, taking advantage of natural topography and vegetation to screen the feedlot site.
- Design should cater for both staged construction and future expansion, with the feedlot able to operate efficiently at any stage of growth.



Horses used for pen riding need stables and facilities

Capital costs versus operating costs

A compromise between design objectives may sometimes be required. A design with a low initial capital cost will probably cost more to operate and maintain in the future. For example, capital costs can be reduced by installing gravel rather than concrete aprons around water troughs, but this may lead to high maintenance costs for repairs to the pen floor around the trough.

Installing cheap, gravel aprons often compromises the environmental performance of the feedlot since bog holes around the water trough increase odour emissions and may cause cattle welfare problems.

Capital cost savings by reducing 300 mm of feed bunk space per head to 200 mm per head may be offset in the future by decreased animal performance or increased occurrence of sick cattle due to shy feeding.

Mandatory requirements

Compliance with:

- Relevant Commonwealth, state and local authority codes, regulations and relevant Australian standards as applicable to feedlot development.
- *National Guidelines for Beef Cattle Feedlots in Australia (MLA, 2012a)*.
- *National Beef Cattle Feedlot Environmental Code of Practice (MLA, 2012b)*.

Technical requirements

A wide range of information is needed before an appropriate design of feedlot layout can be proposed.

Information and data requirements

Site plans

Aerial photographs, cadastral plans, road access, utilities.

Survey data

Cadastral survey (e.g. boundary, easements), feature and topographic survey (e.g. utilities, natural/man-made features). See *Section 7* for more detail on survey requirements.

Guidelines and Codes of Practice

Relevant design criteria for feedlot layout elements.

Land resource data

Overlays of soil types, vegetation, wetlands and natural features.

Topography and drainage

Topographic data, overlays of watercourses and floodplains.

Separation distances

Buffer distances from the feedlot complex to sensitive receptors including residences, portion boundaries, public roads, watercourses, bores and vegetation.

Visual impact

Assessment of the visual impact of the site from neighbouring residences and public roads. “Out of sight, out of mind” is a benefit of good feedlot site layout.

Design choices

Fundamental design choices that will influence the overall layout include

Stocking density

Stocking density has a significant influence on the environmental performance of a feedlot since it partly determines the average moisture content of the pad. Every day, cattle add moisture to the pen surface by depositing manure (faeces and urine).

The chosen stocking density that should achieve a balance between a pen surface that is, on average, too dry and one that is too wet depends on local climate and cattle size. (See *Section 9 – Overall pen layout* for more information on stocking density.)

The stocking density chosen will also determine the size and number of pens required and hence have a significant impact on construction and operational costs.

Feed bunk length per head

Feed bunk length can vary from 200 mm/head to over 300 mm/head. The 300 mm bunk requires 50% more volume of concrete per head than the 200 mm bunk, and hence influences capital cost. Bunk length per head, along with stocking density, determines the width and depth of the pens.

(See *Section 19 – Feeding systems* for more information on bunk length per head.)

Pen capacities

Pen sizes in commercial feedlots may range from 50 head to 300 head. In custom feeding operations a variety of pen sizes allows management to cater optimally for different sized customer consignments.

When large consignments of cattle are fed long term, poor performers may be drafted off during the feeding period. These cattle may start in 300-head pens and some will end up in 50- and 100-head pens.

Many managers prefer a 100-head pen to finish cattle as this matches consignment sizes for transportation and container sizes for carcasses and boxed beef. The smaller pens are generally located closer to the cattle receipt and dispatch facilities.

(See *Section 9 – Overall pen layout* for more information on pen capacity.)

Pen and drain slope

Good pen drainage is essential to prevent odour problems and boggy pen conditions for the stock. Pen slopes can range from 2.5% to 6% but a gradient of 3–3.5% appears optimal. Slopes under 3% do not drain well, particularly if there is a buildup of manure.

Slopes over 4% can result in high rates of sediment removal during heavy storms particularly in deep pens or poorly cleaned pens, and this can cause problems throughout the whole of the drainage system.

The slope chosen may depend on site topography. For flat sites where earthworks are required to artificially create slope, lower



Stocking density and pen capacity



Feed bunk design, space per head and stock barriers

pen slopes (2.5–3%) are often chosen. For steeper slopes such as hillsides, the natural topography usually determines the pen slope. In both cases, the orientation of the rows of pens should ensure adequate drain slope (0.5–1.5%).

(See *Section 10 – Pen and drainage systems* for more information on pen and drain slope.)

Shade

The need for shade is determined by feedlot site, climatic conditions, cattle breeds and other factors. If shade will be installed the orientation of the pens becomes important, as the preferred orientation of the shade is north-south.

As the sun moves during the day, the shade available to the cattle moves across the width of the pen. An east-west orientation of shading prevents movement of the shaded area over the pen surface during the day and this can lead to localised buildup of moisture and manure under the shade structure.

(See *Section 16 – Shade* for more information on shade.)

On-site road systems

The on-site road infrastructure is important to the overall layout. Factors such as the pitch, gradient and camber of roads affects vehicle stability, accurate feed delivery and road and vehicle damage over time.

Other factors include fitting the road to the natural contours of the land, road width, number of livestock lanes and feed truck turnarounds. The practicalities of feedlot access and safety also need to be considered. (See *Section 13 – Access and internal roads* for more information.)

Arrangement of facilities

There was a tendency to group the key feedlot facilities, particularly feed storage and preparation, cattle handling and the office, at one site in the middle of the feedlot but experience has shown that this arrangement rarely results in optimal functional performance. The preferred arrangement of facilities is to separate these three main systems.

All incoming and outgoing vehicles should travel past a single point or the main office where a truck weighbridge is located. This provides security and control over site entry as well as improved inventory control.

After passing the office, vehicles travel to either the feed receipt/processing area or to the cattle receipt/dispatch area. The cattle handling and feeding systems can be managed separately and both operate fairly independently with little operational interference. The practical examples of site layouts that follow demonstrate this independence.



Shade – orientation, shape and material

Feeding pen configurations

Feeding pens are typically grouped into rows, usually with

- *Back-to-back* configuration with a central feed alley servicing pens on both sides of the roadway. Both sets of pens drain away from the feed alley to a stock alley or effluent drain.
- *Sawtooth* configuration with the feed alley servicing a single row of pens falling away from the road to a cattle lane or effluent drain.

Back-to-back configurations are probably more efficient in terms of feed delivery, time and fuel usage, but are generally suited only to relatively flat sites (<2%). Sawtooth layouts are the only cost-effective layouts for steeper sites (>2%) where the pen slope matches the natural slope.

Pen rows should be straight. Curved rows were once advocated as this suited a curved hillside. However, pen dimensions and bunk length per head are rarely uniform in these layouts, and it is difficult to deliver feed to a curved feed bunk without feed spillage and/or damage to the bunk due to collisions with feed trucks.

Basic layout choices

The following practical examples show feedlot layouts for large and small feedlots that follow the design principles outlined above.

- Feeding pen rows should be straight.
- Pen rows should be either back-to-back configuration or sawtooth configuration.
- Feeding, cattle handling, manure removal and drainage systems should be independent.
- Feed roadways should not cross cattle lanes or drains.
- The controlled drainage area should be as compact as possible.
- Visitors, commodity, cattle and manure trucks should enter and leave the site via a single entry/exit point or by passing the office/weighbridge.

Examples of overall layout



*Overall site layout:
All vehicles enter from the lower left
of the photograph. After going past the
office, cattle trucks turn to the left while
feed delivery trucks continue straight on.*

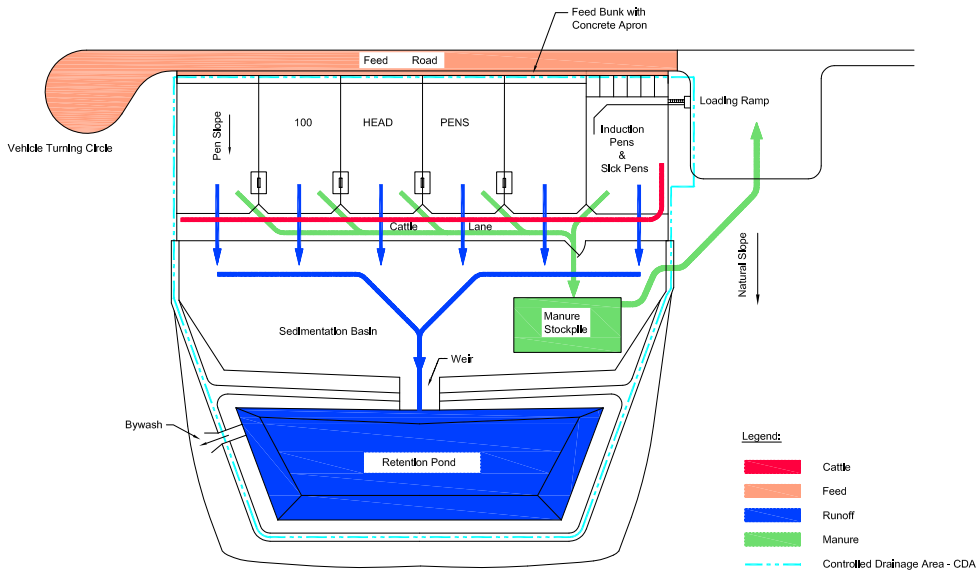

Small-size feedlot. Conceptual layout with single row of feeding pens.



Small feedlot with single row of equal-sized pens. This layout has sufficient area for expansion.

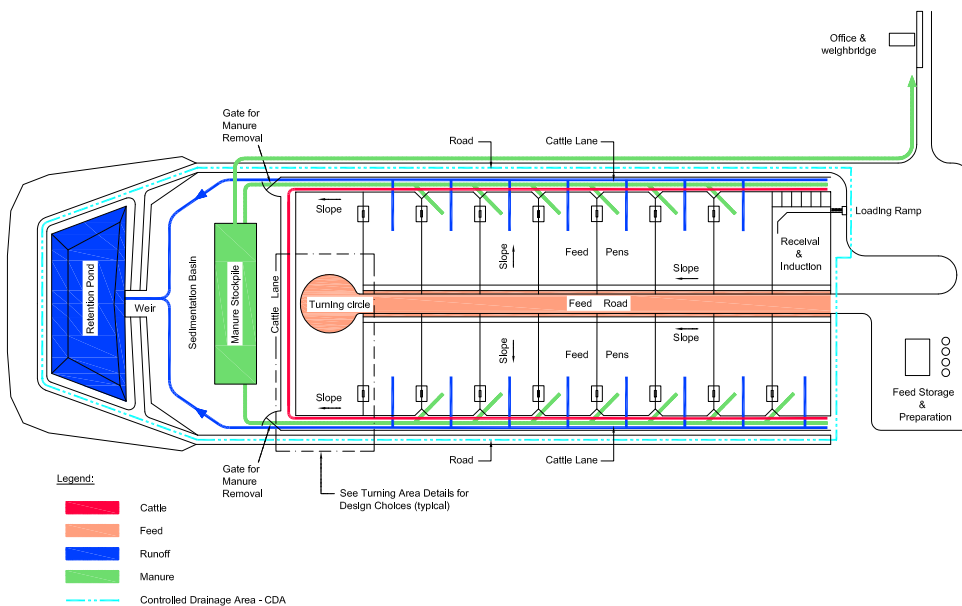

Medium-sized feedlot. Conceptual layout with back-to-back pen configuration.

Medium-sized feedlot. Conceptual layout with sawtooth pen configuration.

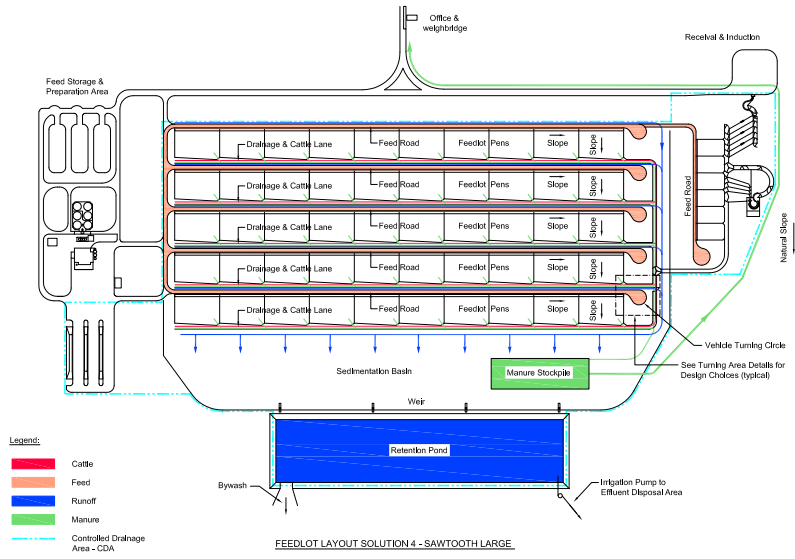

Medium-sized feedlot with sawtooth pen layout and straight rows. The cattle handling system is at the bottom of the site while the feed processing system is on the opposite side of the feedlot.



Sawtooth pen layout around the hill with central feed processing area. A curved layout is not desirable.



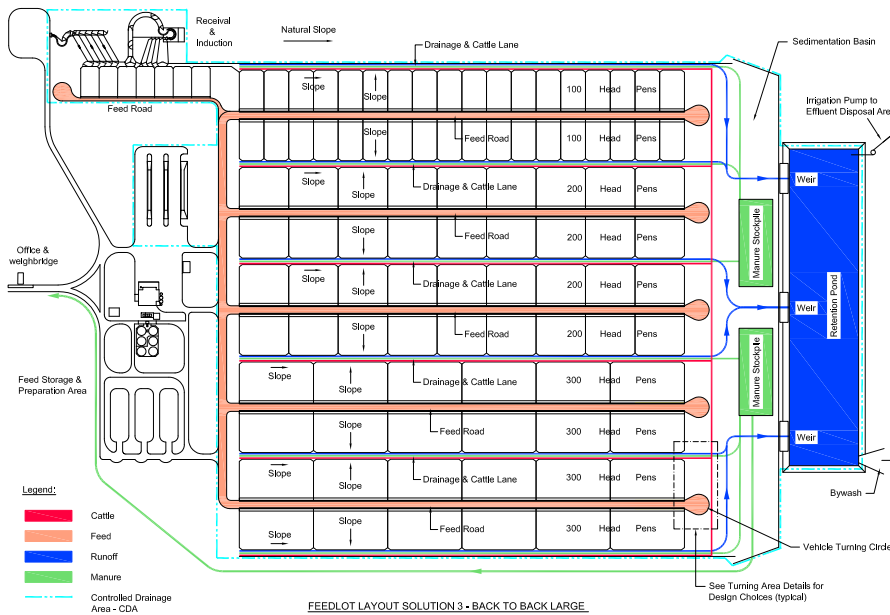

Large-sized feedlot. Conceptual layout with back-to-back pen configuration.



Back-to-back straight rows with feed processing and cattle handling located on one side.

Layout details

Subsequent sections in this manual provide detail on most aspects of feedlot design. However, some details are specifically related to overall feedlot layout.

Long feed roads

In some layouts, the rows of pens can become quite long (up to 1000 m). It is operationally inefficient for feed trucks to travel to the far end of each row if they are delivering feed only to the pens near the start of the row.

In addition to turning circles at the end of each feed road, turning circles can be installed in the middle of a row as it is generally unsafe to back feed trucks out of a feed road. Feed roads can be sealed with bitumen to minimise dust and damage to the feed truck. However, as a tight turning circle with a small mid-point can rapidly damage a bitumen surface, it can be left as compacted gravel.



Curved feed roads and curved feed bunks should be avoided. Feed is often spilled and the bunks damaged by the feed truck.

Use of areas adjacent to feed truck turning circles

At the end of each feed row, there is a turning circle for feed trucks (assuming that the feed trucks do not cross cattle lanes) and this inevitably creates a space either side of the turning circle with a slope similar to that of the pen. This 'vacant land' could be used for hospitals, hospital pens, short production pens and/or road access for manure trucks. The following figures show options for the use of this 'vacant land' in back-to-back pen layouts.

- Option A is a mid-lane turning circle for extended feeding roadways.
- Option B is a small production pen. This requires a bend in the feed bunk.
- Option C is a hospital treatment area.
- Option D is vacant or green space.
- Option E is an access point for manure trucks.

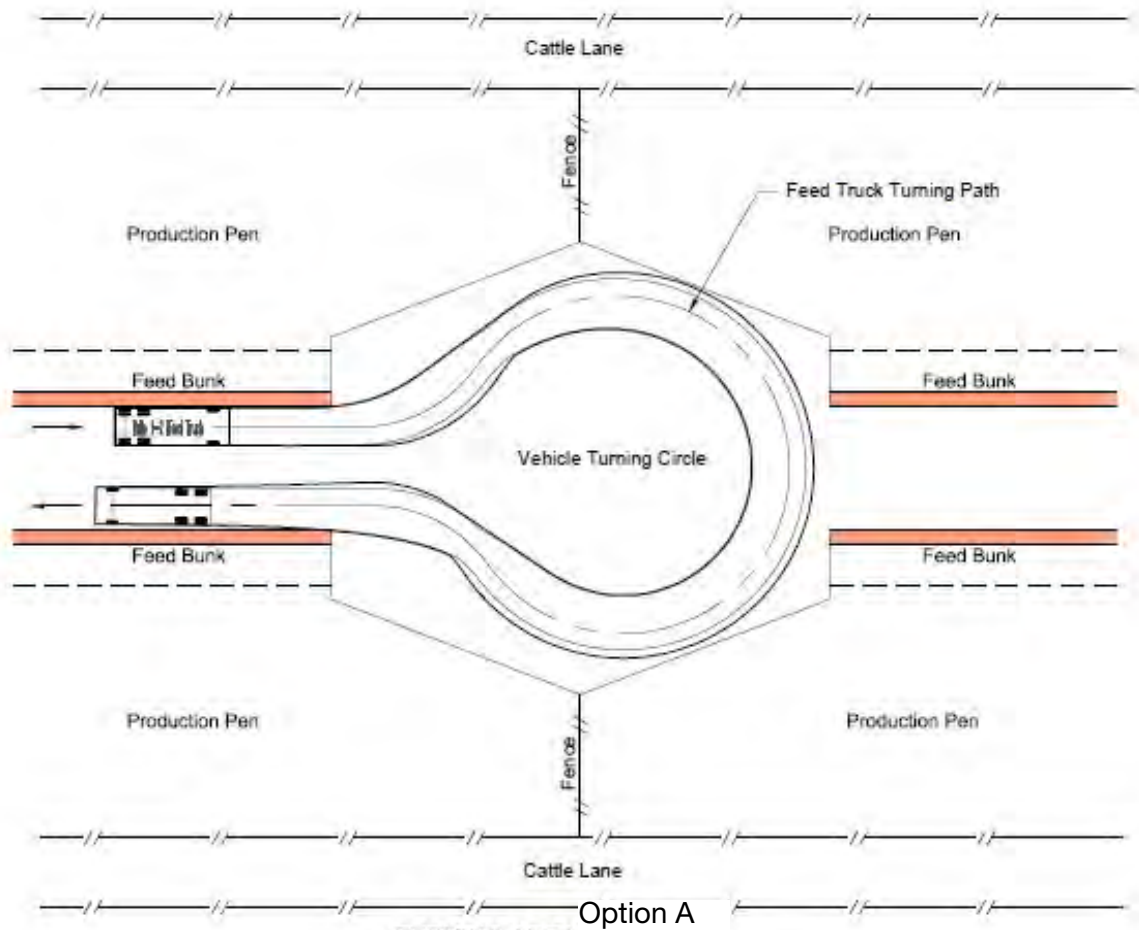

Option A - Mid-lane turning circle for extended roadways

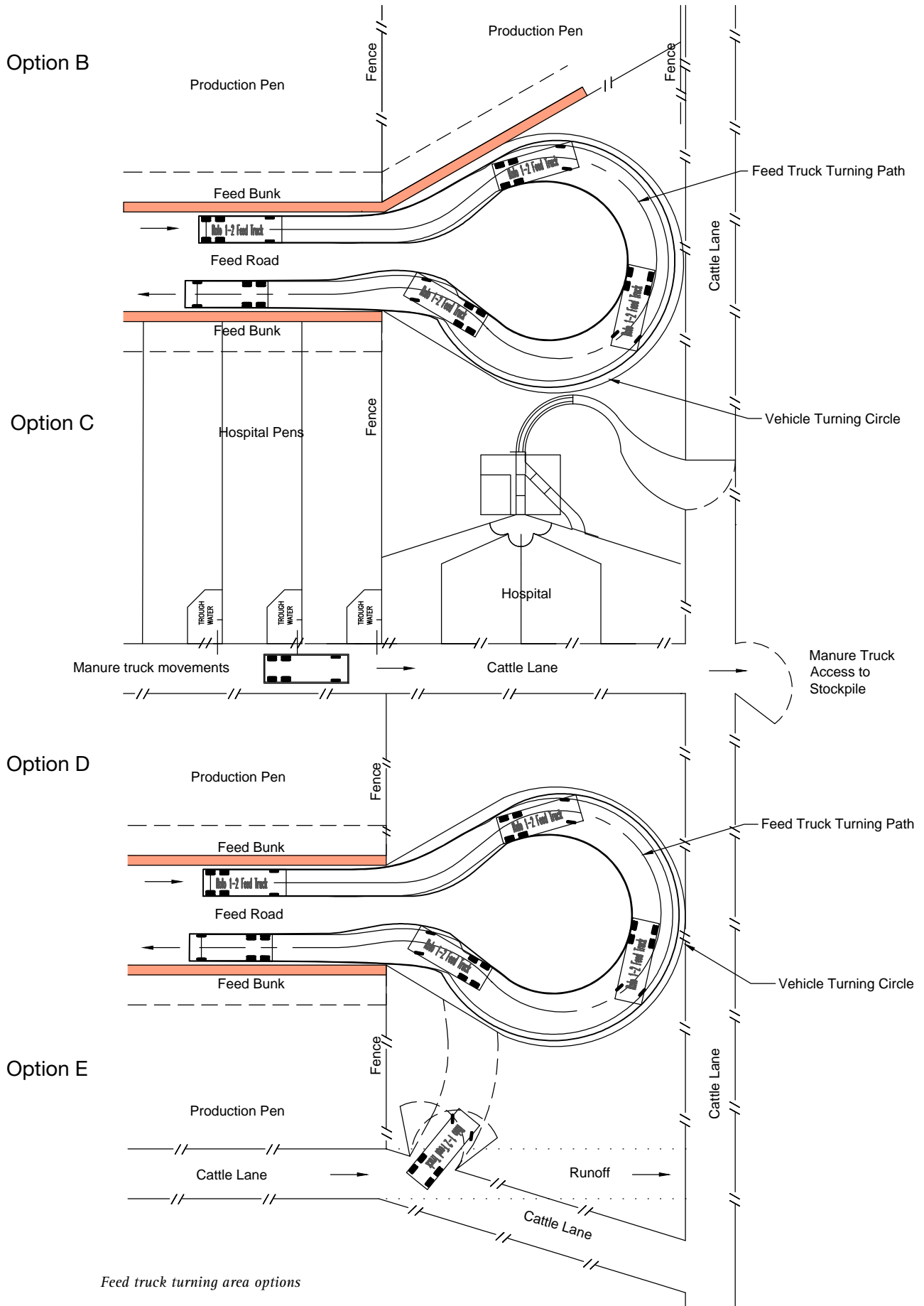

Feed truck turning area options



Gates giving vehicle and livestock access to pens from the feed alley



Gates at the top end of a cattle lane allow access for pen cleaning equipment and manure trucks

Manure truck access

Access to a pen for pen cleaning and manure removal equipment is generally through the cattle lane and is facilitated by herringbone gates. However, adequate access is also required at both ends of the cattle lane.

Manure truck movement in cattle lanes is usually one way (i.e. the manure truck cannot turn around) and manure trucks need a swept entry/exit radius (appropriate to the size of vehicle), wider gates and a firm road base when exiting loaded.

Adequate access means entry/exit road slopes that are trafficable by fully-loaded manure trucks with sufficiently wide gates to allow turning of trucks (and trailers if attached).

Gates in feed bunks

In the past, some feedlots have installed gates into pens giving access from the feed road, but moving cattle to the cattle handling facility using the feed roads is not efficient practice. However, gates off the feed road do give pen access to pen cleaning and manure removal equipment without the need to use the cattle lane/drain. This may be a viable option for manure truck access in some configurations.

Further reading

Guidelines for the establishment and operation of cattle feedlots in South Australia, Department of Primary Industries and Resources (SA) and Environment Protection Authority, 2006, Adelaide.

Guidelines for the Environmental Management of Beef Cattle Feedlots in Western Australia, Bulletin 4550, 2002, WADo Agriculture (ed.), Western Australia Department of Agriculture, Perth, WA.

National Guidelines for Beef Cattle Feedlots in Australia - 3rd Edition, Feedlot Industry Accreditation Committee (ed.), June 2012, Meat & Livestock Australia, Sydney, NSW.

National Beef Cattle Feedlot Environmental Code of Practice - 2nd Edition, Feedlot Industry Accreditation Committee (ed.), June 2012, Meat & Livestock Australia, Sydney, NSW.

Paine M, Teter, N and Guyer, P (n.d) 'Feedlot Layout', in *Great Plains Beef Cattle Handbook*, GPE-5201.

Skerman, A 2000, *Reference manual for the establishment and operation of beef cattle feedlots in Queensland*, Information Series QI99070, Queensland Cattle Feedlot Advisory Committee (FLAC), Department of Primary Industries, Toowoomba, QLD.

The New South Wales feedlot manual, 1997, NSW Agriculture, NSW Agriculture, Department of Land and Water Conservation, Department of Urban Affairs and Planning & Environment Protection Authority, Orange.

Victorian code for cattle feedlots, August 1995, Victorian Feedlot Committee, Department of Agriculture, Energy & Minerals, Melbourne.



FEEDLOT DESIGN AND CONSTRUCTION

3. Water supply sources and on-site storage

AUTHORS: Rod Davis and Peter Watts

Introduction

Water for feedlots can be obtained from a number of different sources. These may be surface water such as creeks, rivers, dams, channels and land surface diversions, or groundwater which can be shallow or deep artesian bores. Whatever the source, the suitability of water that the site has available and the predicted water required for the future will depend on its quantity, quality and reliability.

As intensively-fed beef cattle must have an uninterrupted supply of clean water, every feedlot should have contingency plans for pump or pipeline failure. Water supply may be interrupted for many hours or even days due to natural disasters (damage to infrastructure), electricity blackouts, pump or pipeline failure. A temporary emergency (back-up) water supply and suitably sized water storage close to the feedlot are essential.

Design objectives

The design objectives for water supply sources and onsite water storage for a feedlot are to

- have a legal right to the required volume for the intended use
- have a reliable supply of the required volume to sustain the operations of the feedlot
- provide a second source of water in the case of failure of the primary source
- be able to store an adequate quantity of water matched to duration and the number of cattle it will be expected to serve
- ensure adequate quantities of drinking water are available in the event of system failure, malfunction or some other interruption to supply
- provide a supply of water to cattle at all times
- store fresh, cool, clean, palatable and high quality water
- cater for daily variations in water supply and demand
- minimise water losses
- provide a safe working environment for people
- have a level of quality appropriate for the intended use.

Mandatory requirements

Compliance with

- Australian Animal Standards and Guidelines for Cattle (DAFF, 2013)
- National Guidelines for Beef Cattle Feedlots in Australia (MLA, 2012a)
- National Beef Cattle Feedlot Environmental Code of Practice (MLA, 2012b)
- quality standards for beef cattle drinking as outlined in the Australian and New Zealand Guidelines for Fresh and Marine Water Quality (2000) (ANZECC and ARMCANZ 2000).
- relevant state and local authority codes and regulations as applicable to feedlot development water licensing and supply.

Technical requirements

Sources of water

Water for feedlots can be obtained from surface water, groundwater or municipal supplies or a combination of all three.

Wherever possible, feedlots should have more than one water supply source (e.g. river plus bore or bore plus dam). If one source fails, the feedlot can change to the other.

Surface water

Surface water supplies from streams, rivers and runoff into farm dams can be highly variable seasonally and annually in many parts of Australia. Surface water supplies may also include diversions from both floodplains and upland areas.

Floodplain harvesting is the collection, extraction or impoundment of water flowing across floodplains.

Rainfall runoff harvesting and overland flow harvesting take rainfall runoff from local watersheds. These diversions are often stored in an excavated structure or gully dam or hillside dam.

Surface water is mostly good quality and is suitable without extensive treatment for most feedlot uses – except as boiler feedwater. See *Section 5 – Water quality* for more information on water quality required for boilers.

Groundwater

Groundwater supplies are generally less variable than surface water supplies and evaporation losses are negligible. Once the volume of water required for the feedlot and the recharge rate of an aquifer are known, the volume of water that will be available can be predicted with a degree of certainty.

However, uncertainty over the volume of groundwater may become an issue if groundwater sources are depleted because of overuse or extended drought. In these instances, licensing restrictions may be imposed.

Groundwater is usually good quality and suitable for most feedlot uses without extensive treatment. Again, the exception is boiler feedwater which will most likely require some form of treatment to remove impurities.

Groundwater is mostly sub-artesian pumped from an aquifer. Locating and drilling a bore that will provide adequate, high quality water is an expensive task that requires the assistance of a qualified hydrogeologist. There is no guarantee that groundwater is present in quantities necessary for the intended needs.

Artesian groundwater is found in the Great Artesian Basin and can flow naturally to the surface when tapped by a bore. Generally, artesian water has a temperature ranging from 30°C to 100°C.



Water supplies from creeks and rivers are variable across Australia. Water taken from creeks and rivers for use in intensive agriculture and/or irrigation is regulated in most areas.



Water taken from land surface diversions (LSD) is regulated in most areas. LSD are characterised by infrequent takes of high volumes of water.



Land surface diversions need off-stream storages. Losses from evaporation and seepage can be large.



The reliability of the water supply will need to be assessed.



Australia has many ephemeral creeks and rivers.

Municipal supply

Relatively few rural enterprises in Australia source their water from a municipal water system. However, for feedlots, the advantages of a municipal water system include

- generally high reliability with few supply interruptions
- water is treated to a higher standard than generally needed for livestock and boiler water
- water is delivered under pressure.

The main limitations of a municipal water system may include

- not available in all locations
- costly to extend the water supply line to the feedlot
- a long delivery line from the meter may result in a drop in pressure
- public water is expensive incurring connection fees, minimum monthly costs and costs for excess water use.

Legal right to use the water

In Australia, water rights allow water resources to be managed and used in a way that maximises their value to society.

Water rights limit the volume of water that any individual can take and places obligations upon the individual that protect the rights of others, and may also specify a range of other requirements such as when water may be used.

In some states, water rights are the personal property of water users; in others, they are vested in the state. Areas that may have unregulated water resources are unlikely to be suitable for feedlot development.

A secure water supply means the legal right to the required volume for the intended use. In areas where water usage is regulated, this usually requires an industrial or similar high security water licence, allocation or entitlement.

Bores that are licensed only for 'stock and domestic' use cannot be used for feedlots without a change to the licence and the granting of an annual allocation or limit. In some areas, there are restrictions on the capture of rainfall runoff.

Water quality

Feedlots depend on an adequate supply of suitable quality water.

Water quality refers to the characteristics of a water supply that will influence its suitability for a specific use. Quality is defined by certain physical, chemical and biological characteristics.

While an ideal situation is to be able to select from several supplies, normally only one is available. In this case, the quality of the available supply must be evaluated to see how it fits the intended use. *Section 5 – Water quality* provides more information on water quality requirements at feedlots.

Reliability of supply

When planning a feedlot, the reliability of the water supply must be assessed to ensure that the intended water source(s) are sufficient to meet both the average feedlot water requirements throughout the year, as well as the peak demand days and times of the day.

In most areas of Australia, the management of water resources is complicated by the seasonal variability in supply because of the year-to-year variability in rainfall.

Surface water

Rainfall and the hydrology of catchments determine the overall volume of surface water available. To improve the reliability of supply, rivers and streams are regulated using dams and weirs.

In most areas of Australia, river and/or stream extractions are regulated to satisfy both downstream consumptive demands and environmental flow requirements. The time of extraction may be dependent on maximum and minimum flows at specific times and locations, and this needs to be considered when assessing reliability.

For land surface diversions, the catchment yield and/or the flooding frequency will need to be assessed, preferably by a suitably qualified and experienced person such as a hydrologist or agricultural engineer.

The catchment yield and the proposed types of water use will usually determine the size of the storage. A shallow storage (i.e. less than four metres deep) will suffer larger evaporation losses than a deeper one with a similar volume. Typically, to cater for extended periods of dry weather and droughts, the size of a surface storage might need to be three to four times the annual feedlot water usage plus a provision for dam evaporation.

Groundwater

Bores are generally a much more reliable source of water than surface water, and so are preferred by lot feeders. However, in recent years, some areas have been affected by regulatory restrictions on nominal allocated licence volumes.

For groundwater, establishing a bore often involves a large financial outlay and its capacity to meet long-term demand must be properly tested.

Testing the yield of a bore should be carried out by people experienced in the hydrological behaviour of pumped bores. A proper analysis will also take into account details such as location of water beds and bore construction. The yield test for the bore should determine

- the stability of the aquifer
- its maximum capacity
- the design pumping rate for a particular scheme
- the optimum pump inlet level
- its long term reliability.

Bores that produce a sufficient volume of water but do not have the capability of meeting peak water demands will require a buffer storage. The water can then be gravity fed (or re-pumped) from the storage at a much faster rate to meet or supplement the peak demand periods.

The ability to supply cool drinking water is important during summer, particularly for artesian bore supplies where the ground water is delivered at temperatures in excess of 35°C.



A groundwater bore located several kilometres from the feedlot site. Water taken from underground is regulated in most rural regions.



Groundwater bores are usually drilled on feedlot properties where surface water dries up during extended dry weather. They can be a primary or secondary supply source.



Artesian water may need spray cooling.



Uncovered turkey nest storage next to a feedlot



Uncovered turkey nest storage near a feedmill



Growth of vegetation around open earthen storages can result in significant water losses due to extraction, and will enhance algae growth.

Onsite storage

Feedlots need an onsite water storage to overcome differences in supply and demand and to also provide an emergency storage for temporary supply failures.

Emergency water storages can be constructed from almost any material as long as they safely store water at a reasonable cost. Most emergency water storages are either steel or concrete above-ground tanks or earthen embankment storages. Ideally, the emergency water storage should be part of the normal feedlot water supply system, so that it can cater for diurnal variations in supply and demand and at the same time remain relatively full in the event of an unexpected supply failure.

Earthen embankment storages

Earthen embankment storages are often referred to as ring tanks or turkey nest storages depending on their size and/or location across Australia, and are filled by pumping water from some other source.

The ring tank is in the shape of a ring (or square or rectangle) bounded by a compacted earthen embankment and usually located on relatively flat ground. The material required for the embankment is excavated from inside the embankment, hence water can be stored above and below the natural ground level.

A turkey nest storage is similar to the ring tank but the embankment material is brought from the outside. As all water is stored above natural surface level it can be gravity fed to the point(s) of usage.

Each earthen embankment storage is unique in size, shape, capacity, location, soil and environmental characteristics and hence has to be designed individually. They are constructed using the same techniques as feedlot holding ponds. See *Section 12 – Holding pond design* and *Section 8 – Bulk earthworks* for information on design and bulk earthworks of embankments.

A ring tank or turkey nest may be covered using various forms of material to prevent contamination, wildlife, pests and other animals from accessing the water storage. Covers also reduce evaporation and algal buildup in the water distribution system and provide an even water temperature in the supply.

Above-ground tanks

Above-ground tanks are an alternative to earthen embankment storages. They can be constructed from various materials (e.g. concrete, polyethylene, corrugated iron), are available in various sizes and generally have an enclosed roof. Most steel or concrete tanks can be supplied with a cover.

When located on a stand or high point above the feedlot pens, gravity assists flow of water to the off-take points.

The cost per volume of storage of these tanks is much higher than from earthen storages.

Temporary supply

Trucking emergency water is expensive and requires intensive management. It should be considered only as a temporary solution or in extreme emergencies.

Size

Emergency or back-up water sources sufficient to meet the basic water requirements of cattle during peak demand days and the anticipated emergency period must be incorporated in the design and planning process. This supply or storage should be of sufficient capacity to supply water to cattle under summer conditions until breakdowns can be repaired.

The National Feedlot Guidelines state that the emergency supply should be capable of supplying basic water requirements (e.g. domestic and livestock water) for at least 48 hours in mid-summer.

Where some infrastructure (e.g. deep artesian bores) may take much longer than 48 hours to repair, a secondary water supply source or large temporary supply is essential.

For sizing the water storage, the drinking water consumption rates for cattle are outlined in *Section 4 – Water requirements*. The number of days of storage required depends on the anticipated time needed for pumping systems to come back online. The following formula can be used to determine the emergency storage volume.

Storage Volume (L) = Peak drinking water (L/head/day) × Pen capacity × No. of supply days.

For example a feedlot with 1000 head on feed needs a two-day emergency supply volume of
 = 40 L/head/day × 1000 head-on-feed × 2
 = 80,000 L

Industry data on the number of available days of temporary storage at feedlots ranges from 1 day to 500 days with an average of 34 days (MLA, 2014).

Location of storage

The emergency water supply should be located close to the production pens and at the highest practical point on the site. This allows gravity flow of water to the production pens during interruption or loss in electricity supply.

Covering of open storage

Covering open storages can reduce evaporation losses, reduce algae growth and maintain water at a constant temperature. Covers also exclude water birds that can defecate in the open water supply and potentially transmit disease. See *Section 4 – Water requirements* for calculation of evaporative losses. Most steel or concrete tanks can be supplied with a cover.

A major limitation to covering large open storages is the cost of the cover – both upfront and for potential ongoing maintenance.

Physical covers, such as floating or shade structures, are the most appropriate and effective and many products are available. Key



Concrete water storage tanks of various capacities may be cast in-situ. Most have concrete or galvanised iron roofs.



Steel or corrugated iron water storage tanks are available in a range of sizes and capacities.



This siren alerts management when water in the tank drops to a critical level.



Covering emergency water storages helps reduce water evaporation and prevent access by wildlife and pests.



Synthetic liner to minimise water seepage



Rope nets are an important safety feature in synthetic-lined storages to allow escape if people or animals fall in the storage.

factors in selection are the cost of water (e.g. town water supply versus underground), percentage water saving, capital, operating and replacement costs, impact on water quality and deployment and storage safety issues.

In some cases, covering temporary open storages is undesirable e.g. hot water from a deep artesian bore should be allowed to cool before being supplied to cattle, especially during seasons of high daily air temperatures. A spray inlet also assists with cooling.

Floating covers

Floating covers are well suited to storages with a small surface area but are difficult to install with surface areas greater than five hectares. In some cases, these covers can be deployed as a series of large rafts covering up to 1 ha each.

Fully covering a turkey nest with an impermeable continuous floating plastic cover can reduce evaporation by more than 90%.

Most of these products have a high capital cost and replacement life is typically between 10 and 20 years. Tensioning systems vary from wire rope to mechanical systems.

Water quality can be impacted by reduced dissolved oxygen, light penetration and change in water temperature, but this will reduce algal growth.

Disadvantages of floating covers are the relatively high capital outlay, difficulty in installation on large storages and potential high repair and maintenance costs, especially following storms and winds.

Supply and installation is usually carried out by accredited installers. This involves the supply and welding of the materials to correct lengths, with final joining and fastening taking place in-situ.

Shade structures

Shade structures reduce solar radiation and wind speed and affect evaporation, by trapping humid air between the structure and the water surface.

Shade structures are generally suspended above the water surface using a web-like structure of cables with shade cloth fitted between the cables.

The shade cloth can come in a range of UV ratings (See *Section 16 – Shade*).

Shade structures are generally less effective in reducing evaporation than floating covers, but evaporation savings of 70–80% have been demonstrated in trials.

Although shade structures allow free flow of oxygen to the water, algae growth may be reduced by the lower light penetration.

Most of these products have high capital and low maintenance costs, but all have a limited life. They are more appropriate to small storages given the need to suspend the shade cloth above the water with a cable structure.

Similar shade cloth and fixtures as used for pen shade may be used.

Storage lining

Failure to hold water is the most common problem with earthen water storages. Water seepage may be mitigated by lining with

- natural or engineered in-situ low hydraulic conductivity soils
- clay liners
- synthetic liners.

Section 8 – Bulk earthworks provides further information on clay and synthetic liner systems.

Safety considerations with water storage

Safety is always a concern around open water storages but slippery plastic covers can present an extreme danger to anyone who might fall in and be unable to clamber out.

Actions to minimise the risk associated with emergency water supply storages include

- educating employees and visitors about the hazards around emergency water supply storages.
- installing and maintaining appropriate safety signs, safety fence, gates, locks and barriers.
- using a safety harness when working near embankments of plastic-lined open storages.
- having rescue equipment, such as floatation devices and rope nets, available at plastic-lined open water storages.
- advising people not to enter enclosed spaces.



Livestock-proof or security fencing will keep livestock or visitors from open storages.



Restricted area sign near water storage

Quick tips

- All feedlots must have a secure water supply; this will have a primary and a secondary supply source.
- The site and proposed sources of water must be carefully assessed from both a physical and legal perspective.
- Surface water supplies are highly variable seasonally and annually. How much water is available and when it may be available must be reliably assessed.
- Review the regulatory requirements for reliably obtaining the required volume of water from a particular source.
- Assess the water quality concerns of water supply sources to determine if any additional treatment is needed before its intended use.
- An emergency water supply source and onsite storage should be provided to meet water demand in the event of unusual circumstances.
- As emergency water supply storage is expensive, its location (topography, gravity versus pumping, additional storage, soils suitability) and type of storage (e.g. concrete tank versus earthen storage) warrant careful consideration.
- Calculation of water demand incorporates evaporative (and seepage) losses for open earthen storages.

Further reading

DAFF, 2013, Australian Animal Standards and Guidelines for Cattle, Department of Agriculture, Forestry and Fisheries, Australian Government, Canberra, ACT.

MLA, 2012a, National Guidelines for Beef Cattle Feedlots in Australia. Meat & Livestock Australia, Sydney, NSW.

MLA, 2012b National Beef Cattle Feedlot Environmental Code of Practice. Meat & Livestock Australia, Sydney, NSW.

Addison, JS, Law, RJ and Eliot, GB 2003, Dam Design for pastoral stock water supplies, Bulletin 4576, ISSN 01448-0352, Agdex 754, Department of Agriculture, Government of Western Australia.

Bradshaw, B. 2002a, 'Dairy effluent: pond construction', AG0425, Dept. of Primary Industries, Melbourne.

EPA 2004, 'Wastewater and evaporation lagoon construction: EPA Guidelines', Environmental Protection Authority, South Australia, Adelaide.

Ham, J.M. 2002, 'Seepage losses from animal waste lagoons: a summary of a four-year investigation in Kansas', Transactions of the ASAE, 45(4), 983-992.

Horton, AJ and Jobling, GA 1984, Farm water supplies design manual / Farm Water Supplies Section, Irrigation Branch, Queensland Water Resources Commission; edited by A.J. Horton and G.A. Jobling.

United States Bureau of Reclamation 1977, Design of small farm dams, USBR, Washington DC.

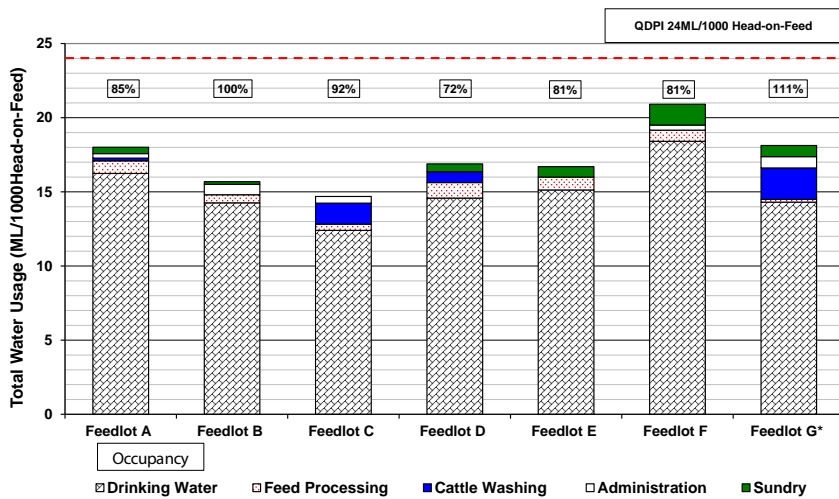

FEEDLOT DESIGN AND CONSTRUCTION

4. Water requirements

AUTHORS: Rod Davis and Peter Watts

Introduction

With the variable climate and greater stresses being placed on water resources, water availability and security cannot be taken for granted. Water is a vital resource for lot feeding and can also be a significant expense.

Most of the water used is for cattle to drink; it is also used for feed processing, cleaning yards, machinery and cattle washdown, other general practices around the feedlot and in amenities for people working on the feedlot. Water is also lost through evaporation and seepage from open storages. An accurate understanding of water usage in the industry is important for determining licence requirements for water supply.

Design objectives

The design objectives for a feedlot's water requirements are to

- meet the feedlot's total annual water requirement
- provide an unrestricted, reliable supply of water to livestock at all times of the year
- provide water that is clean, fresh and free from contamination for livestock
- meet the peak water intake requirement for feedlot cattle, especially during summer
- minimise losses and maximise water use efficiency
- ensure that the quality of the water (which includes temperature, salinity and impurities) does not affect livestock performance or welfare
- provide water that is clean, fresh and free from contamination for people.

Mandatory requirements

Compliance with

- Australian Animal Standards and Guidelines for Cattle (DAFF,2013).
- National Guidelines for Beef Cattle Feedlots in Australia (MLA, 2012a).
- National Beef Cattle Feedlot Environmental Code of Practice (MLA, 2012b). Performance measure 1.5.2 states that a feedlot has a water supply able to sustain the operations of the feedlot under normal conditions.
- relevant state and local authority codes and regulations as applicable to feedlot development water requirements and licensing.
- quality standards for beef cattle drinking are outlined in the Australian and New Zealand Guidelines for Fresh and Marine Water Quality (2000) (ANZECC and ARMCANZ 2000).

Technical requirements

To identify feedlot water supply and system requirements, the following steps should be conducted

- Determine the feedlot total water supply requirements. Read this section and *Section 28 – Feed preparation and storage* and *Section 41 – Cattle wash facilities*.
- Complete an inventory of all water sources, supplies and related problems (Refer *Section 3 – Water supply sources and onsite storage*).
- Identify any potential water shortages or water system problems (Refer *Section 3 – Water supply sources and onsite storage*).
- Identify solutions to improve water supply or water systems (Refer *Section 14 – Water reticulation systems*).

Total water requirements

A rough overall estimate of the daily requirement for watering stock is 5 litres per 50 kg liveweight, but this is greatly influenced by animal feed intake, ambient temperature and the weather. Traditionally, the total annual water requirement for feedlots has been based on the QDPI Reference Manual for Beef Cattle Feedlots value of 24 ML/1000 head on feed. This figure makes an allowance for uses other than cattle drinking requirements, such as trough cleaning, minor leakages and veterinary purposes, but not for significant other usage.

Total clean water usage is the combination of drinking water, feed processing, cattle washing (where this practice is undertaken), administration and direct sundry uses such as trough cleaning, dust control, vehicle and facility cleaning and indirect sundry ‘uses’ such as evaporation. This does not include water used for effluent dilution.

Figure 1 presents total water usage data from seven Australian feedlots between 2007 and 2009. The total water usage ranged from 14.5 to 20.5 ML/1000 head-on-feed; 90% of this was used for drinking when no cattle were washed, 84% during months when cattle were washed. Over a year, cattle drank an average of 40 L/head/day (31–46 L/head/day).

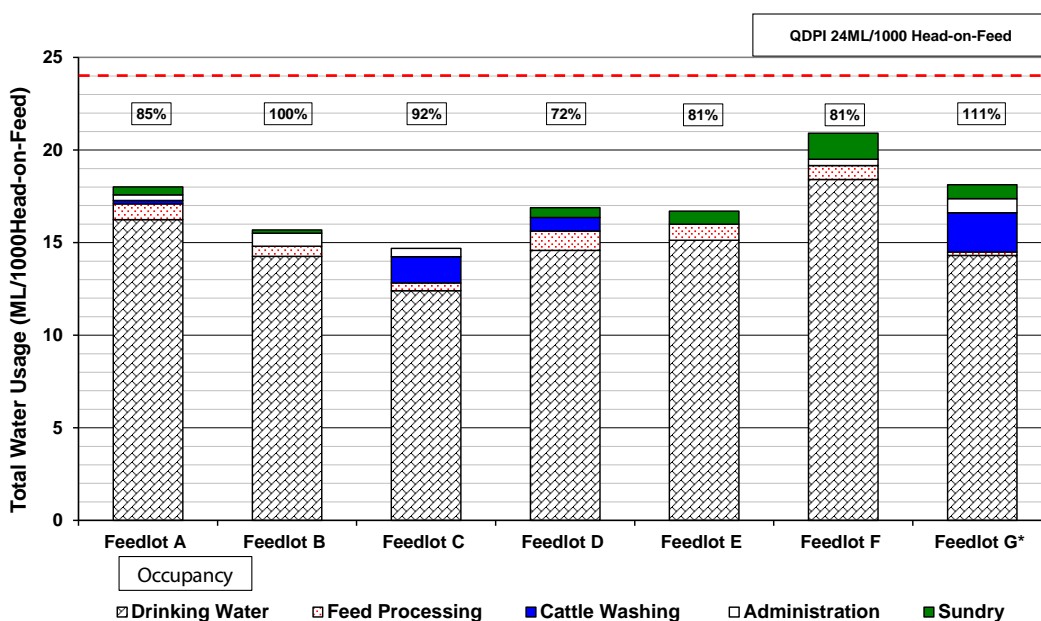

Figure 1. Total annual water usage (ML/1000 head-on-feed) for seven feedlots (Davis et al. 2009)

Livestock drinking water

Water is vital for livestock survival, but restricting water intake also immediately reduces feed intake and so cattle performance and production.

The water requirements of livestock are met by

- water consumed voluntarily (i.e. water that is drunk)
- water consumed in feed
- water retained within the body due to oxidation reactions involved in metabolism.

Factors affecting water consumption

The quantity of water consumed by feedlot cattle depends on environmental factors (e.g. ambient temperature and humidity), drinking water temperature, water quality, ration composition (nature of food and dry matter content), feed intake, size of the animal, rate and composition of gain, frequency of watering and individual variation between animals.

Environmental factors

Water intake increases with higher ambient temperature. Other environmental factors affecting the volume of water consumed by the animal include relative humidity, wind speed, solar radiation and rainfall.

Breed

Bos indicus cattle drink significantly less than the *Bos taurus* breeds.

Diet composition, feed intake and body size

The dry matter content and the nature of feed both affect water consumption. Cattle eating more, drink more.

Growing animals require more and better quality water than those that have finished growing and are being fattened, but heavily finished cattle need more water than leaner beasts.

Water intake

Over a year at seven Australian feedlots, cattle drank an average of 40 L/head/day. At a subtropical feedlot, they drank 44 L/head/day, while those at a feedlot that experiences cold winters, mild summers and high rainfall drank 30 L/head/day.

However, there appears to be no consistent relationship between heat load index, rainfall and temperature on drinking water consumption.

Seasonal variation in daily drinking water consumption

Daily water consumption patterns in lot-fed cattle vary with the season and can range from about 14 L/head/day to 75L/head/day. Daily drinking water consumption differs between summer and winter (Figure 2) and with significantly different patterns.

Pattern of consumption

During summer, cattle start to drink from the earlier sunrise, with consumption peaking between 10.00 and 14.00 hours. It then drops about mid-afternoon, peaks again between 16.00 and 17.00 hours, after which it gradually decreases until a few hours after the later sunset when it remains steady until midnight.

In winter, cattle also start drinking at the later sunrise with water consumption peaking at 13.00-16.00 hours. It then decreases from late afternoon until a few hours after the earlier sunset after which consumption remains steady until midnight.

Peak demand

The peak flow rate demands are much greater during summer than during winter. The average peak flow rate on summer days can be nearly 70% higher than on winter days, with a maximum peak flow rate being 50% higher. Water consumption varies through the day, and the peak reticulation rate must be incorporated into the design of the feedlot water supply.

Feedlots located in hot and humid climates should have their water supply system and capacity of the on-site water storage designed to accommodate peak demand in the order of 75 L/head-on-feed/day during summer months.

Feedlots located in climates with temperatures around 20°C can be expected to have an average demand for drinking water in the order of 30 L/head-on-feed/day.

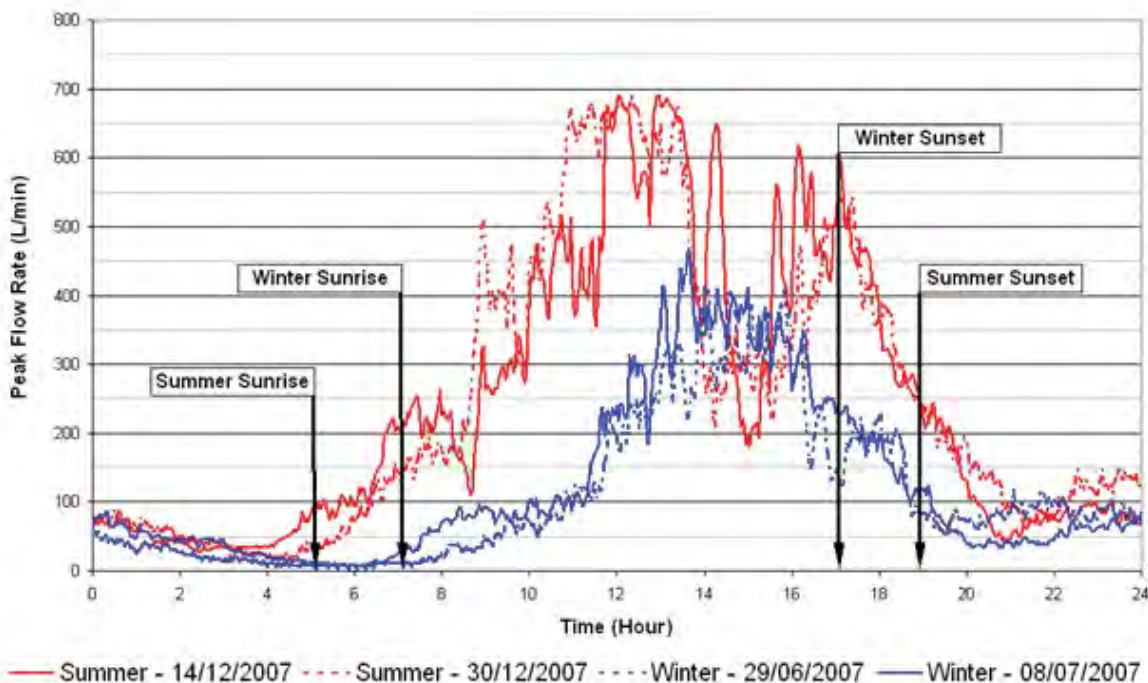

Figure 2. Comparison of daily consumption of drinking water between summer and winter

Diurnal variation in drinking water consumption

Drinking water consumption increases with increasing heat load (Figures 3 and 4) with peak drinking water consumption occurring about two hours after the peak heat load each day.

Water consumption varies throughout the day, and the peak reticulation rate must be incorporated into the design of the feedlot water supply. Peak drinking water consumption occurs about two hours after the peak heat load each day, with two distinct drinking periods throughout each day linked to the feeding periods.

During these periods, consumption peaked at 4.8–5.6 L/head/hour, thus peak flow rate needs to be about 25% greater than the average daily demand (litres/head-on-feed/day) and 100% greater than the average monthly demand (litres/head-on-feed/month). Hence, a water supply and reticulation system needs to be capable of delivering up to double the average monthly demand.

The flow rate to individual troughs should supply at least the daily peak consumption in a 4-hour period.

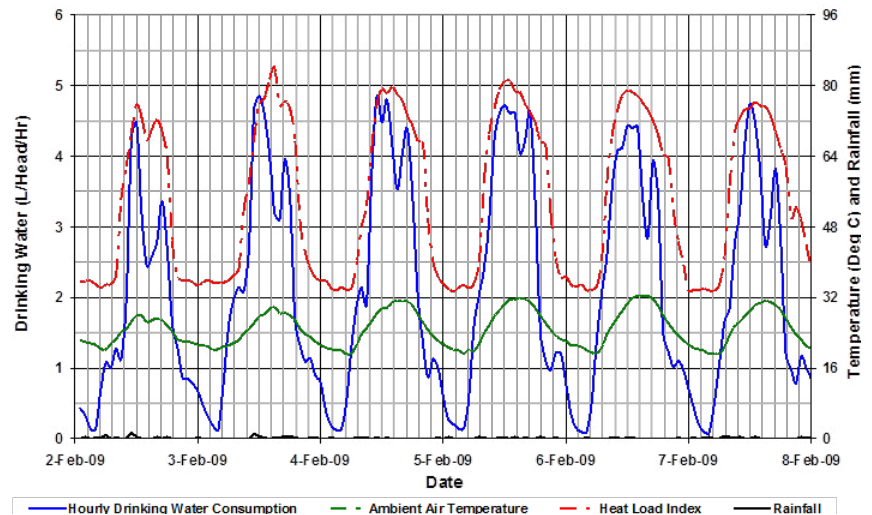

Figure 3. Diurnal variation in drinking water consumption (L/head/hour) at feedlot during a variable heat stress load (February 2009)

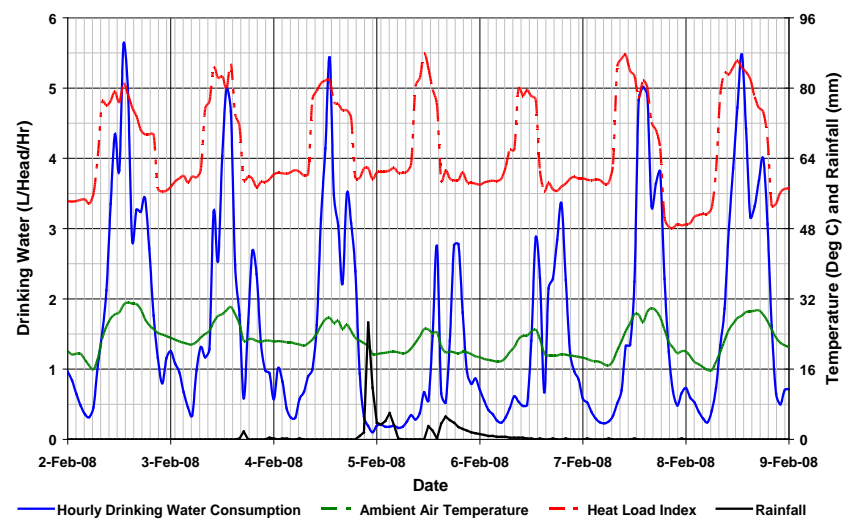

Figure 4. Diurnal variation in drinking water consumption (L/head/hour) at the same feedlot during a consistently high heat stress load (February 2008)

Feed processing

The amount of water used in feed preparation depends upon the feed preparation process used (Refer to *Section 29 – Grain processing equipment*). The different feed preparation processes can be broadly defined as ‘wet’ (e.g. steam flaking, reconstitution, tempering) and ‘dry’ processing (rolling).

– *tempering*

Tempering increases the moisture content of grain to 18–22% and requires the addition of 73–128 L of water per tonne of grain (0.073–0.128 L water per kg of grain).

– *steam flaking*

Steam flaking usually results in grain with a moisture content similar to that of tempered grain (18–22 %), but may require up to twice the volume of water to account for that lost as escaping steam.

– *reconstitution*

Reconstitution usually results in grain with a moisture content of 28–32%. Increasing the moisture content of one tonne of grain from 12% to 30% requires approximately 257 L of additional water (0.257 L water per kg of feed).

In Australian feedlots, average water for grain processing ranges from 90 to 390 L/t grain processed depending on the system employed, grain type, target moisture and management of the system. Water used in grain processing is about 4% of total water usage.

Table 1 can be used to estimate water requirements for grain processing.

Table 1. Estimation of water usage for grain processing

Final moisture content	Initial moisture content		
	10%	11%	12%
Water added per tonne of grain (L/T)			
18%	98	85	73
19%	111	99	86
20%	125	113	100
21%	139	127	114
22%	154	141	128
23%	169	156	143
24%	184	171	158

Cattle washing

Feedlot cattle may need to be washed before slaughter to reduce hide contamination (Refer to *Section 41 – Cattle washing*). The cattle most affected by dag formation are British breeds (*Bos taurus*) commonly found in areas with winter-dominant rainfall. Short-haired or smooth-coated cattle (*Bos indicus*) typically found in northern Australia require little or no washing, especially during the dry season.

The volume of water used to wash cattle will depend on the amount of manure accumulated on the cattle, the cleanliness standard required at the processing plant, number of cattle washed, level of wastewater recycling implemented and seasonal conditions.



Water used in steam generation for grain processing accounts for about 4% of total water usage.



Cattle washing is more prevalent in areas with winter-dominant rainfall and *Bos taurus* cattle.

The total water used for cattle washing ranges from an annual average per feedlot of 400 L/head washed to 2,500 L/head washed, but a monthly average water usage up to 3,500 L/head washed has been recorded. In Australian feedlots, water used in cattle washing is about 3.5% of total water usage.

Administration

Administration water usage comprises that used in offices and amenities and more importantly, for watering of lawns and gardens. Administration represents only 2–3% of the total water usage.

On average, each person working on the feedlot may use about 150 L of water per day through toilets, for washing, in the kitchen and laundry. A rule of thumb guide for the number of people required for a feedlot is about one person for every 750 to 1000 head of capacity. At 1 person per 750–1000 head of capacity, water used by people is equal to 0.18 L/head-on-feed/day.

Sundry uses

Minor water use activities may include

- water trough cleaning
- evaporative losses from open water storages (troughs, ring tanks, turkey’s nests)
- cleaning – hospital, receival/dispatch areas, feed processing areas, weighbridge
- vehicle and machinery washing bays
- dust control in pens and on roads
- drinking water for horses or other stock.

Water for sundry uses may range from 0.03 to 4.1 L/head-on-feed/day or about 3% of total water usage.

Cleaning water troughs

Water losses at troughs arise from the water lost (dumped) during trough cleaning, evaporation from the surface and sundry pipeline or float fault leakages. Losses associated with trough cleaning are therefore related to trough capacity, as water troughs are completely emptied during cleaning, and cleaning frequency.

Evaporation losses from open storages

Net evaporation loss is the net loss of water from open storages and troughs after accounting for rainfall. Evaporative losses can be significant depending on the area of open storages, particularly in the summer months, which is when demands for water are greatest.

Open-water evaporation is calculated by applying a ‘pan factor’ to the measured evaporation.

$$E = K_p \times E_{pan}$$

where

E = open-water evaporation (mm/day)

K_p = pan factor, constant determined by the pan siting, relative humidity and wind speed.

E_{pan} = Class ‘A’ pan evaporation (mm/day)



The volume of water used for cleaning troughs depends on trough capacity and frequency of cleaning.



Large open-water storage areas can lose over 800 mm/year through evaporation.

The net evaporation loss would be estimated as

$$E_N = E \text{ less rainfall}$$

The value of K_p can vary widely. From a farm lagoon containing animal waste, the ratio between lagoon and pan evaporation was typically between 0.7 and 0.8.

The net evaporation loss for Dalby, Queensland could be estimated as follows. Mean annual Class 'A' pan evaporation is about 2000 mm and mean annual rainfall is about 600 mm, with an open-water pan coefficient (K_p) of 0.74 (Weeks 1983).

$$\begin{aligned} E_N &= (0.74 \times 2000 - 600) \text{ mm/yr} \\ &= 880 \text{ mm/yr} \end{aligned}$$

The volumetric evaporation loss can be calculated from the equation below.

$$\text{Volumetric loss (m}^3\text{)} = \text{Net evaporation (m)} \times \text{Surface area of storage (m}^2\text{)}$$

Mean annual Class 'A' pan evaporation can be obtained from various sources, including the Bureau of Meteorology or SILO (www.longpaddock.qld.gov.au). SILO is an enhanced climate database hosted by the Queensland Science Delivery Division of the Department of Science, Information Technology, Innovation and the Arts (DSITIA). SILO contains Australian climate data starting in 1889, in a number of ready-to-use formats suitable for research and climate applications. Table 2 provides the Class 'A' pan evaporation for various lot feeding regions in Australia.

For example, consider a 10,000 head feedlot at Dalby, Queensland with an open water storage and surface area of 1,600 m². A net evaporation loss of 880 mm per year at this location represents a loss of 1.40 ML/year or 3,850 L/day on average. This is about 0.4 L/head-on-feed/day – much less than the drinking water intake in the order of 55 L/head/day.

Table 2. Mean annual Class 'A' pan evaporation at various locations

Location	Mean annual pan evaporation (Epan) (mm/yr)
Southern Queensland (Dalby)	2000
Southern New South Wales (Narrandera)	1970
Northern New South Wales (Moree)	2312
Victoria (Charlton)	1788
South Australia (Murray Bridge)	1734
Western Australia (Corrigin)	2060

Table 3 summarises the measured and estimated sundry water uses at seven Australian feedlots (between 2007 and 2009) on a per head on feed basis.

The three largest sundry water losses or uses, namely water storage evaporation, trough cleaning and road watering, depend on the total open water surface area, net evaporative losses, trough size and frequency of cleaning and cleaning method and road maintenance. Sundry losses depend on feedlot design, location (climate) and operational management.

Table 3. Sundry water uses for seven Australian feedlots

Feedlot	A	B	C	E	F	G	H
Water trough evaporation	0.6	0.7	5.1	0.4	0.3	0.3	0.4
Water trough cleaning	35.2	24.2	16.1	10.8	3.9	1.2	15.9
Hospital/Induction cleaning	15.5	0.0	7.7	13.4	2.2	8.4	7.0
Vehicle washing	4.9	0.0	14.5	0.6	0*	0.0	5.5
Road watering	43.8	9.5	3.1	40.6	0*	0.0	0.0
Water storage evaporation**	230	0.0	1450	910	4.3	161	0.0
TOTAL L/head-on-feed/year	330	34.5	1497	977	10.7	171	28.9
TOTAL L/head-on-feed/day	0.9	0.1	4.1	2.7	0.03	0.5	0.1

* Data unavailable **Data estimated (Davis et al. 2009)

Dilution of effluent

Runoff from the controlled drainage area is contained within a sedimentation and holding pond system. (Refer to *Section 10* for further information on controlled drainage systems.) The effluent may need to be diluted during application as its nutrient level can be too concentrated for complete plant absorption. This can lead to nutrient runoff and contamination of surface or groundwater sources.

The quantity of water used for supplementation or dilution of effluent for irrigation is highly variable between feedlots. Some feedlots use evaporation as the primary means of effluent disposal and do not require additional water for irrigation.

Where effluent is reused for irrigation of crops, the amount of additional clean water required depends on the 'strength' of the effluent being irrigated and the area of land to which it is applied. To illustrate generally, if 50 ML of effluent was to be reused through land irrigation with a 50% dilution rate, then 50 ML of clean water would be required.

Dilution ratio is site specific and should be based on matching nutrient concentration and crop requirements.

Quick tips

- Cattle must have an unrestricted, reliable supply of water at all times of the year.
- Total average annual water requirement for feedlots includes cattle drinking requirements, feed processing, cattle washing, administration and sundry uses (trough cleaning, minor leakages, other stock drinking water, cleaning, dust control) and dilution of effluent.
- The water supply must be appropriately licensed and reliable in times of peak demand.
- Water usage must be understood to maximise water use efficiency.
- Total water usage depends on cattle type and feeding regimes, environmental conditions, climate, feed processing system and management, number of cattle washed and level of wastewater recycling implemented and sundry uses.
- Data from Australian feedlots indicates that the average daily drinking water requirement is in the range of 30–50 L/head/day depending on feedlot climatic zone and cattle type.
- The average daily drinking water requirement in summer ranges from 50 to 65 L/head/day depending on feedlot climatic zone and cattle type.
- Peak hourly drinking water requirement in summer ranges from 4.8 to 5.6 L/head/hour depending on feedlot climatic zone and cattle type.
- Water consumed by cattle accounts for about 90% of the total water usage.
- Water used in feed processing is about 4% of total water usage.
- Water used in cattle washing is about 3.5% of total water usage.
- Water used for sundries is about 3% of total water usage.

Further reading

- ANZECC, 2000, Australian and New Zealand guidelines for fresh and marine water quality: Volume 1 - The guidelines. Australian and New Zealand Environment and Conservation Council Agriculture and Resource Management Council of Australia and New Zealand – 2000.
- ARC (Agricultural Research Council). 1980. The nutrient requirements of ruminant livestock. 2nd ed. Commonwealth Agricultural Bureau, Farnham Royal, U.K.
- Arias, RA and Mader, T 2008, Modelling Daily Water Intake in Cattle Finished in Feedlots, Nebraska Beef Report, pp 74-77.
- Australian Government, 2013, Animal Standards and Guidelines for Cattle, Department of Agriculture, Fisheries and Forestry. Canberra, Australia.
- Beckett, JL and Oltjen, JW, 1993, Estimation of the Water Requirement for Beef Production in the United States, J. Anim. Sc. 71: 818-826.
- Blackshaw, JK and Blackshaw, AW 1991, Effects of shade on production and welfare of feedlot beef cattle: roles of animal and environmental factors in heat strain. Unpublished report for the Meat Research Corporation, Sydney, Australia.
- Carter, WJ, 2008, Investigation of Lot Fed Cattle Drinking Water Consumption, Meat & Livestock Australia, P.PIP.0171, Final Report, Sydney, NSW.
- Chiew, F, Wang, Q., McConachy, F., James, R., Wright, W. and deHoedt, G., (2002). Evapotranspiration Maps for Australia.
- Church, DC 1979, Taste, appetite and repetitive regulation of energy balance and control of food intake. In: D. C. Church (ed.) Digestive Physiology and Nutrition of Ruminants. Vol. 2, Nutrition. O&B Books Inc, Corvallis, Ore.
- DAFF, 2013, Australian Animal Standards and Guidelines for Cattle, Department of Agriculture, Forestry and Fisheries, Australian Government.

- Davis, RJ and Watts, PJ, 2006, Environmental Sustainability assessment of the Australian Feedlot Industry – Part A: Water usage at Australian Feedlots, Meat and Livestock Australia, project FLOT.328 Final Report, Sydney, NSW.
- Davis, RJ, Watts, PJ and Tucker, RW, 2006, Environmental Sustainability assessment of the Australian Feedlot Industry – Part E: Review of Lot Fed Cattle Water Consumption – MRC Project No. DAQ.079, Meat and Livestock Australia, Project FLOT.328 Final Report, Sydney, NSW.
- Davis, RJ, Wiedemann, SG, and Watts, PJ (2009) Quantifying the water and energy usage of individual activities within Australian feedlots – Part A Report; Water Usage at Australian Feedlots. Meat and Livestock Australia, Project FLOT.0339 Final Report, Sydney, NSW.
- EA Systems Pty Ltd, 2004, Cooling water for lot-fed cattle, Final Report FLOT.322. Meat and Livestock Australia Ltd, North Sydney.
- EA Systems Pty Ltd, 2002, Measuring Microclimates variations in Two Australian Feedlots, Final Report FLOT.310. Meat and Livestock Australia Ltd, North Sydney.
- EA Systems Pty Ltd, 2003, Applied Scientific Evaluation of Feedlot Shade Design. Commercial-in-confidence, Final Report FLOT.315. Meat and Livestock Australia Ltd, North Sydney.
- Flamenbaum, I, Wolfenson, D, Mamen, M, and Berman, A, 1986, Cooling Dairy Cattle by a Combination of Sprinkling and Forced Ventilation and its Implementation in the Shelter System, *Journal of Dairy Sci.* 69: 3140-3147.
- Gaughan et al, 2001, Strategies to Reduce High Heat Load on Feedlot Cattle, Louisville, Kentucky (USA), ASAE.
- Gaughan J B, Goopy, J and Sparke, E J 2002, Excessive Heat Load Index for feedlot cattle. Final Report FLOT.316 Meat and Livestock Australia Ltd, North Sydney.
- Gaughan JB, 2004, Refinement of the heat load index based on animal factors. Final Report FLOT.319 Meat and Livestock Australia Ltd, North Sydney
- Gill, JY. 1984. Suitability of waters for stock – interpretation of water analysis results. *AgDex* 400/582. R14/Jul 84. Ag Chem Branch. QDPI: Indooroopilly.
- Ham, JM 1999, Field evaluation of animal-waste lagoons: seepage rates and subsurface nitrogen transport, Animal Waste Lagoon Water Quality Study. Kansas State University, Kansas State University, Manhattan, KS.
- Ham, JM 2007, 'Measuring the seepage rate from lagoons using an overnight water balance test', in International Symposium on Air Quality and Waste Management for Agriculture, Broomfield, Colorado, 16-19 September 2007, American Society of Agricultural and Biological Engineers, St. Joseph, Michigan.
- Hicks, RB, FN Owens, DR Gill, JJ Martin and CA Strasia. 1988. 'Water Intake by Feedlot Steers', Animal Science Research Report, Agricultural Experiment Station, Oklahoma State University, 1988, No. MP-125, 208-212.
- Ferguson, D, Colditz, I and Fisher, A, 2008, Animal welfare assessment in cattle feedlots – A Review, Final Report B.FLT.0347. Meat and Livestock Australia Ltd, North Sydney.
- Forster, SJ 2005 Beef cattle feedlots: Feed processing, Queensland Department of Primary Industries and Fisheries.
- Hofman, MP, Self, HL, 1972, Factors Affecting Water Consumption by Feedlot Cattle, *J Anim Sci* 35: 871-876.
- Luke, GJ 1987. Consumption of water by livestock. Technical Report No 60. Division of Resource Management: Western Australian Department of Agriculture, Perth.
- Lyndon, K 1994, The Water Requirements of Lot Fed Cattle Exposed to Hot Australian Conditions Final Year Undergraduate project, AG421 Department of Agriculture, University of Queensland.
- Mader, TL and Davis, MS, 2004, Effect of management strategies on reducing heat stress of feedlot cattle: Feed and water intake. *Journal of Animal Science*, 82:3077:3087.
- McDowell, RE 1972, Improvement of livestock in warm climate, W.H. Freeman and Co, San Francisco, California.
- Meyer, U, Stahl, W, Flachowsky, G, 2006, Investigation on water intake of growing bulls, *Livestock Science* 103: 186-191.
- Parker, DB, Perino LJ, Auvermann, BW and Sweeten, JM 2000, Water Use and Conservation at Texas High Plains Beef Cattle Feedyards, *Applied Engineering in Agriculture*, 16(1):77-82.

Parker, DB, Weinheimerm B, Auvermann, BW and Sweeten, JM, Perino, DVM, 1998 Water Use and Conservation at Beef Cattle Feedyards. 1998 ASAE Annual International Meeting, Sponsored by ASAE Disney's Coronado Springs Resort, Orlando, Florida July 12-16, 1998.

Sanders, P R., Lott, S C, Watts, P J, Tucker, R W, Casey, K D and Lyndon, K, 1994, Lot Fed Cattle Water Consumption, Report 12.A. Meat Research Corporation Project No. DAQ.079, Queensland Dept. of Primary Industries, Feedlot Services Report, Toowoomba, Queensland. July 1994.

SILO – www.longpaddock.qld.gov.au

Skerman, A. 2000. Reference Manual for the Establishment and Operation of Beef Cattle Feedlots in Queensland, Queensland Cattle Feedlot Advisory Committee (FLAC), Department of Primary Industries, Queensland, Information series Q199070.

Standing Committee on Agriculture, 1990, Feeding standards for Australian Livestock (Ruminants). CSIRO, Melbourne, pp193-208.

Sparke, EJ, Young, BA, Gaughan, JB, Holt, SM and Goodwin, PJ, 2001, Heat Load in Feedlot Cattle. Final Report FLOT.307,308,309. Meat & Livestock Australia Ltd, North Sydney.

MLA, 2012a, National Guidelines for Beef Cattle Feedlots in Australia. Meat & Livestock Australia, Sydney, NSW.

MLA, 2012a National Beef Cattle Feedlot Environmental Code of Practice. Meat & Livestock Australia, Sydney, NSW.

Utley, PR, Bradley, NW and Boling JA 1970, Effect of restricted water intake on feed intake, nutrient digestibility and nitrogen metabolism in steers. Journal of Animal Science. Vol 31. pp. 130-135.

Weeks, WD 1983, The calculation of Evaporation in Queensland. Qld Div Tech Papers, IE Aust. Pub, Brisbane. No QBG 1756.

Winchester CF and Morris MJ (1956), Water intake rates of cattle, Journal of Animal Science, 15:722-740.



FEEDLOT DESIGN AND CONSTRUCTION

5. Water quality

AUTHOR: Rod Davis

Introduction

The water supply for feedlots can come from a number of sources with different water quality. Water sources include surface water (dams, rivers, creeks, channels), groundwater (bores, wells) or municipal supply.

In evaluating a feedlot water source, emphasis is generally placed on the chemical and physical characteristics of the water as they relate to cattle drinking water.

Cattle are sensitive to water taste and odour and may drink less if the water is unpalatable. Newly arrived cattle may be reluctant to drink water that has an unusual odour or taste, causing short-term stress. Contaminated water sources can affect the animal's water intake and animal performance or health.

Problems with water quality may have a chemical basis (e.g. pH or concentrations of certain elements) or may be due to physical causes (e.g. turbidity when the water is cloudy with suspended solids) or biological (algae). Some problems may be obvious while others may require more extensive analysis and treatment.

Water from some sources may be of an unsuitable quality for an intended use. Specific uses may need different quality e.g. good quality river water may be used successfully for irrigation but because of its sediment load, be unacceptable for cattle drinking water or boiler feedwater. Similarly, groundwater of excellent quality for cattle drinking water may be too corrosive for boiler feedwater use without appropriate treatment.

Design objectives

The design objectives for feedlot water quality are to provide levels that

- do not affect livestock water intake
- do not affect livestock health
- do not affect livestock performance
- do not affect the health of people
- minimise maintenance requirements on water supply and distribution infrastructure
- can be suited to other uses such as boiler water, vehicle and machinery washing.

Mandatory requirements

Compliance with

- Australian Animal Standards and Guidelines for Cattle (DAFF, 2013)
- National Guidelines for Beef Cattle Feedlots in Australia (MLA, 2012a) which states that a feedlot water supply is suitable for quality for stock use
- National Feedlot Accreditation Scheme (AUS-MEAT, 2013)
- Australian and New Zealand Guidelines for Fresh and Marine Water Quality – quality standards for beef cattle drinking (2000) (ANZECC and ARMCANZ 2000)
- relevant state and local authority codes and regulations as applicable to feedlot development in regards to water quality.

Technical requirements

Evaluation of water quality depends on its specific use within a feedlot. Information related to drinking water quality requirements for livestock, other intended uses at a feedlot and water sampling and testing guidelines are outlined in the following sections.

Assessing water quality

Water quality should be assessed before and sometimes during use.

Water quality assessment is generally based on

- physical/organoleptic properties (odour, taste, turbidity, temperature)
- physiochemical properties
- excess nutrients
- toxic substances
- microbiological agents

Physical/organoleptic properties (odour, taste, turbidity, temperature)

Physical properties include temperature and turbidity; organoleptic properties are those aspects experienced by the senses including odour, taste and colour.

Physiochemical properties

Physiochemical properties deal with the physical properties and the chemical composition, and include salinity, sodicity, hardness, pH, total dissolved solids and total dissolved oxygen.

Excess nutrients

The excess of certain nutrients in water supplies can adversely affect livestock health and potentially the environment. Nitrogen in the form of nitrate, and sulphate in the form of calcium, iron, sodium and magnesium salts, can affect the performance of cattle.

Toxic substances

Toxic substances can be defined as a broad group of chemicals capable of causing a health hazard to livestock and/or people working at the feedlot. These substances include

- heavy metals, including aluminium, arsenic, mercury, lead, copper, zinc and cadmium
- organophosphates found in pesticides, insecticides and herbicides
- hydrocarbons
- chemicals e.g. fluoride.

Microbiological agents

Bacteria, viruses, parasites and algae can be found in water sources. While most microorganisms are harmless some, such as blue-green algae, can affect livestock health and reduce performance. A contaminated water source can spread a pathogen (disease-causing agent) quickly throughout the feedlot; for example, leptospirosis can be spread through water supplies.



Water quality should be assessed by collection and analysis of water samples.



Fountains help aerate and cool artesian water and/or storage water during hot weather.



Drinking water can become extremely hot if steel or plastic water pipes are exposed to solar radiation.

Surface water sources can become stagnant during extended periods of dry weather, drought or low flow. Nutrient enrichment and higher water temperatures can generate algal blooms that may contain blue-green algae (cyanobacteria). Livestock have become sick or died from drinking water containing toxins (microcystins) released by blue-green algae.

Evaluating the content of water is relatively straightforward. The major difficulty is establishing levels at which animal health, welfare and productivity may be affected. Advice on site-specific water quality issues should be obtained from a suitably qualified and experienced nutritionist or veterinarian.

Cattle drinking water

Factors that may affect acceptability of drinking water for cattle include

Temperature

Cattle generally prefer water at or below body temperature, and avoid warmer water. They need cool drinking water to help maintain their body temperature during periods of hot weather.

At higher ambient temperatures, cattle drink more water in relation to dry matter consumption. Typically, the optimum temperature of drinking water with regard to performance of the cattle should be about 16–18°C. When the water temperature is above 25°C, water consumption rises more sharply due to the initiation of sweating and increased respiration; above 30°C, cattle tend to drink more often, at least every two hours.

If the drinking water temperature is above 25°C, such as in artesian water, it may need to be cooled. Strategies for cooling water and then maintaining the cool temperatures include evaporative cooling of ponds, buried pipelines, covers on water storages, and smaller capacity water troughs with high water turnover. In evaporative cooling ponds, the water supply could be drawn from the bottom of the pond where it is coolest.

Acidity or alkalinity

Total alkalinity in water is a combined measure of bicarbonates, carbonates, and hydroxide ions as these increase the pH of water. The total alkalinity of water is always less than its total dissolved solids (TDS) or salinity, since TDS and salinity include the sum of the concentrations of all substances dissolved in water, not just bicarbonates, carbonates, and hydroxide ions.

Alkalinity is expressed either as pH or as titratable alkalinity in the form of bicarbonates and carbonates. Alkalinity measures do provide information about the various salt types present in the water, but may be measured and expressed as a concentration of CaCO₃ mg/L.

Alkalinity alone seldom limits the use of water for livestock; however, the precise level of alkalinity that causes problems is not well defined. A concentration level less than 500 CaCO₃ mg/L indicates good quality water, 500–1,000 CaCO₃ mg/L poor quality water that cattle can still tolerate, but over 1,000 CaCO₃ mg/L may cause physiological and digestive impediments in cattle. In order to offset the alkaline pH, acidic ions are required.

Water pH is a measure of concentration of hydrogen ions. A pH of 7 is neutral, a value less than 7 indicates acidity and a value above 7 indicates alkalinity (Figure 1). Drinking water with pH between 6 and 9 is assumed acceptable for cattle and has little influence on rumen pH. However, water sources with a pH below 6.0 or above 8.5 should be further evaluated where unexplained herd health or performance issues occur.

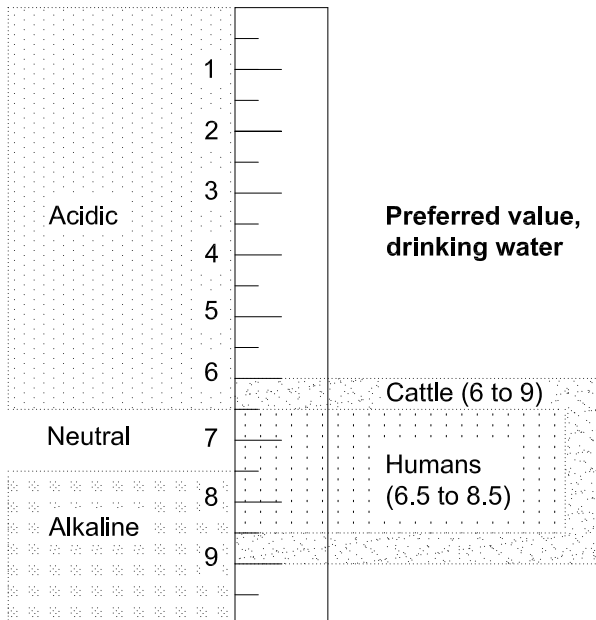

Figure 1. Guideline for pH value

Total Dissolved Solids and Salinity

Salinity refers to the mass of dissolved salts in a solution and is typically determined indirectly by measuring total dissolved solids (TDS). These dissolved salts are often mainly sodium chloride but may include carbonates, nitrates, sulphates of calcium, magnesium and potassium. Generally, surface waters are lower in salts than underground water.

Dissolved salts in water are expressed in milligrams per litre (equivalent to parts per million – ppm) or in terms of the electrical conductivity of the water, measured in decisiemens per metre (dS/m) or microsiemens per centimetre ($\mu\text{S}/\text{cm}$).

1 dS/m = 1000 $\mu\text{S}/\text{cm}$ = approx. 640 mg/L or 640 ppm.

Many factors influence the concentration of salts that cattle can tolerate in their drinking water. Cattle should be introduced to saline water gradually as they tend to become acclimatised to small changes in salinity but large increases can result in illness or even death.

Cattle can tolerate a TDS concentration up to 9,000 mg/L (13.6 dS /m) and for short periods, up to 10,000 mg/L (15.2 dS/m); levels above 10,000 ppm should never be used as water sources for beef cattle.

The ANZECC guidelines (ANZECC 2000) suggest that the desirable maximum TDS concentration for healthy growth of beef cattle is 4000 mg/L (6.25 dS/m), but it is generally recommended that the TDS concentration should not exceed 5,000 mg/L for cattle drinking watering purposes (see Table 1).



Only pH and EC water quality parameters may normally be assessed in-situ. All other parameters must be tested at a NATA-accredited laboratory.

Table 1. TDS concentration for drinking water for livestock (mg/L)

Stock	Desirable maximum concentration for healthy growth	Maximum concentration at which good condition might be expected*	Maximum concentration that may be safe for limited periods*
Beef cattle	4,000	4,000–5,000	5,000–10,000
Horses	4,000	4,000–6,000	6,000–7,000

* The level depends on the type of feed.

Adapted from Australian and New Zealand Guidelines for Fresh and Marine Water Quality 2000.

Cattle are less tolerant of saline water during hot or dry periods. In summer and during dry periods, evaporation increases the salinity of water in dams, troughs and rivers, so it is wise to check salinity if the water supply is naturally salty. Flushing troughs frequently should help to prevent salts from concentrating.

When formulating rations, the salt content of the water should be considered and the salt content of the ration may need to be reduced.

Hardness

Hardness, alkalinity and salinity are not the same. Hardness is the total concentration of calcium and magnesium in water, whereas salinity includes other dissolved solids. Hard water per se is not detrimental to livestock unless the water has a high level of salinity.

Water hardness is defined in terms of calcium carbonate (CaCO₃, also known as ‘lime’). Hardness is a measure of the concentration of divalent metallic cations (++ charged) dissolved in water and is generally expressed as the sum of calcium and magnesium concentrations expressed as equivalents of calcium carbonate. Other divalent metallic cations such as iron and manganese can contribute to hardness, but concentrations are usually much lower than calcium and magnesium.

Total hardness consists of temporary or carbonate hardness and permanent or non-carbonate hardness; the former is removed by boiling, the latter is not. The removal of hardness is referred to as water softening.

Table 2. Calcium and magnesium concentrations and hardness

Description of water	Hardness expressed as CaCO ₃ mg/L
Soft	0–50
Moderate	51–75
Moderately hard	75–150
Hard	150–300
Very hard	>300

Hard waters can cause problems in low-pressure and low-flow watering systems as accumulation of white mineral scale (insoluble calcium and magnesium carbonate deposits) can eventually restrict flow rates in pipelines. Water softeners are used to trap some of the calcium carbonate before it forms this white mineral scale.

Nutrients

(a) Nitrates

Water contamination with nitrates from manure, sewage or fertilisers becomes a serious concern when feed supplies contain high levels of nitrates.

Toxicity occurs when nitrates (NO_3) are converted to nitrites (NO_2) in the rumen of cattle. Nitrate poisoning is generally chronic and can result in reduced feed intake and in severe cases, death.

Nitrate-nitrogen levels in cattle drinking water of 10 mg/L (44 mg/L NO_3) or less are generally considered safe, levels between 10 and 100 mg/L are questionable, levels over 100 mg/L (443 mg/L NO_3) are generally considered unsafe (National Research Council, 1974).

The conversion is $1 \text{ gm/L NO}_3\text{-N} = 4.43 \text{ mg/L NO}_3$

(b) Nitrites

Ingestion of nitrite leads to a more rapid onset of toxic effects than nitrate.

Confusion can arise concerning guideline values for nitrite (NO_2), because similar to nitrates, concentrations are sometimes reported on the basis of their respective nitrogen contents, that is, as nitrite-nitrogen ($\text{NO}_2\text{-N}$). The conversions are as follows:

$$1 \text{ mg/L NO}_2\text{-N} = 3.29 \text{ mg/L NO}_2$$

Water with a concentration of nitrite exceeding 30 mg/L (NO_2) (10 mg/L nitrite-N) may be hazardous to cattle health.

(c) Magnesium

Magnesium is an essential element for animal nutrition. Drinking water from natural sources usually contains magnesium but levels may vary greatly with location and often with season. Magnesium is present in feedstuffs in variable amounts, especially in forages.

There is no current ANZECC guideline for threshold magnesium concentrations in livestock drinking water.

(d) Fluoride

Fluoride occurs naturally in geological formations and concentrations vary depending on the location. Water from some bores has high fluoride concentrations and this can be rapidly increased by evaporation.

Fluorine is a cumulative toxin; thus animals that live longer (e.g. breeding cattle) are more likely to develop chronic fluorosis.

ANZECC guidelines (2000) state that fluoride concentrations greater than 2 mg/L in drinking water for livestock may be hazardous to animal health. If livestock feed contains fluoride, the trigger value should be reduced to 1.0 mg/L.

(d) Sulphates

Sulphate is present in most water sources and is commonly found in the form of calcium, iron, sodium, and magnesium salts, all of which act as laxatives. Elevated levels of these salts can make the water taste objectionable to cattle.



Reeds around water storages may adversely affect water quality.

Sulphates measured as SO_4 should ideally be present in concentrations of less than 500 mg/L. Sulphates present at concentrations of 500–1,000 mg/L indicate poor quality water that cattle may adjust to. Water intake starts to fall at sulphate concentrations of 1,000–2,000 mg/L and continues to drop as sulphate concentrations increase beyond these levels. Levels of sulphate greater than 2,000 mg/L may cause chronic or acute health problems (ANZECC, 2000).

Toxic compounds

Many metal elements are essential nutrients for cattle health but, in excess, may cause chronic or toxic effects. Water from certain sources may contain toxic levels of some metal elements.

The recommended ANZECC guidelines for metal concentrations below which there is a minimal risk of toxic effects are provided in Table 3.

Table 3. Recommended safe levels of heavy metals and metalloids in cattle drinking water (ANZECC 2000)

Metal or metalloid	Upper-limit guideline* (mg/L)
Aluminium	5
Arsenic	0.5
Beryllium	0.1
Boron	5
Cadmium	0.01
Chromium	1
Cobalt	1
Copper	1
Fluoride	2
Iron	not sufficiently toxic
Lead	0.1
Manganese	not sufficiently toxic
Mercury	0.002
Molybdenum	0.15
Nickel	1
Selenium	0.02
Uranium	0.2
Vanadium	0.1
Zinc	20

* Higher concentrations may be tolerated in some situations.

Microbiological agents

A variety of microbial pathogens such as bacteria, viruses, protozoa and parasites can be transmitted to livestock from drinking water sources. The risk of contamination is greatest in surface waters that are directly accessible by livestock or that receive runoff or drainage from a manure source. Groundwater contamination by pathogens has generally been considered to be low.



Dirty drinking water can reduce animal performance.

A contaminated water source can spread a pathogen (disease-causing agent) quickly throughout the feedlot.

The pathogens of most concern include enteric bacteria such as *Escherichia coli*, *Salmonella* and to a lesser extent, *Campylobacter jejuni* and *Campylobacter coli*, *Yersinia enterocolitica* and *Yersinia pseudotuberculosis*. Other bacterial diseases known to affect livestock that may be transmitted through water supplies include *Leptospira* (leptospirosis), *Burkholderia pseudomallei* (melioidosis), *Pseudomonas*, and *Clostridium botulinum* (botulism), *Mycobacteria* (pulmonary disease) and *Cyanobacteria* (blue-green algal toxicosis) (ANZECC 2000).

Coliforms

Because pathogens are not easily detected in water, their presence is inferred by using indicator organisms such as *Escherichia coli* measured in colony-forming units (CFU) per mL.

Since *E. coli* bacteria occur from direct contamination by livestock or human waste, their occurrence is much more serious than total coliform bacterial contamination. *E. coli* bacteria can be found frequently in water troughs due to direct contact with cattle; troughs should be cleaned frequently.

ANZECC guidelines recommend less than 100 thermotolerant (faecal) coliforms/100 mL (median value) for livestock drinking water (ANZECC 2000).

Cyanobacteria (Blue-green algae)

Algae can grow in surface water supplies and water troughs that are not regularly cleaned. Algal blooms may contain a type of photosynthetic bacteria called cyanobacteria (blue-green algae) which produce a microcystin that can be toxic to livestock. If sufficient quantities of the toxin are consumed, paralysis and respiratory failure occurs rapidly. Dead animals are usually found close to the suspect water source.

Waters contaminated with microcystins will have a mouldy, musty or septic tank odour. Although odour is not a test that is typically conducted, waters with these contaminants will also have high TDS, nitrogen, and phosphorus concentrations.

ANZECC guidelines state an increased risk to livestock health is likely when cell counts of *Microcystis* exceed 11,500 cells/mL and/or concentrations of microcystins exceed 2.3 µg/L expressed as microcystin-LR toxicity equivalents (ANZECC 2000).

All algal blooms should be treated as possibly toxic. Removing animals from affected areas and withdrawing the water source until the algae are identified and the level of toxin determined is the only sure method of preventing poisoning. Care should be taken to limit the growth of algae in water for livestock consumption.

Water troughs should be cleaned on a regular basis to prevent algae buildup. Covers or chlorination can prevent algal blooms in temporary water storages.



Dirty water troughs can transmit some cattle diseases.



Algal growth in stagnant water. Some types of algae (e.g. blue-green algae) produce mycotoxins which are toxic to livestock.



Cattle drinking from trough with algal growth.

Boiler feedwater quality

A steam boiler plant must operate safely with maximum combustion and efficient heat transfer, and this is profoundly affected by the quality of the water used to produce the steam in the boiler.

Boilers need to operate under the following criteria

- Freedom from scale – hard water will cause scaling of the heat transfer surfaces and make frequent cleaning of the boiler necessary.
- Freedom from corrosion and chemical attack – water containing dissolved gases, particularly oxygen, will corrode the boiler surfaces, piping and other equipment.

If the impurities in the boiler feedwater are not dealt with properly, they will be carried over into the steam system and cause problems such as

- contamination of the surfaces of control valves and heat transfer surfaces
- restriction of steam trap orifices.

Water treatment for boiler feedwater

Typically on steam boilers, feedwater is treated before the boiler. External water treatment processes (Table 4) can be listed as

- reverse osmosis
- lime, lime/soda softening
- ion exchange.

The suitable water treatment process will depend on the quality of raw water.

Three types of impurities (suspended solids, dissolved solids and dissolved gasses) exist in all supplies and can cause a wide range of problems in boilers. Generally, groundwater contains more dissolved solids and less suspended solids and dissolved gases whereas surface water contains more suspended solids and dissolved gases and less dissolved solids.

Table 4. Common treatment processes

Issue	Suspended solids	Dissolved solids	Dissolved gases
Treatment options	Filtration	Ion exchange softening	De-aeration
	Clarification	De-mineralisation	De-gasification
		Reverse osmosis	De-alkalisation

The optimum pre-treatment scheme for each plant must take the entire system into account. Feedlots should consult boiler engineers for professional advice on the correct water treatment system required for the boiler to be used.

Table 5, Table 6, Table 7 and Table 8 provide water quality guidelines for high-pressure boilers from different organisations – Tables 5 and 6 from American Society of Mechanical Engineers (ASME 2013), Tables 7 and 8 from American Boiler Manufacturers Association (ABMA 2005).

Table 5. Recommended feedwater quality guidelines for water tube boilers (ASME 2013)

Boiler feedwater						
Drum pressure psi	Dissolved O ₂ ppm	Iron ppm	Copper ppm	Total hardness (CaCO ₃) ppm	pH @ 25°C	Oily matter ppm
0–300	7000	0.100	0.050	0.300	8.3–10.0	1
301–450	7000	0.050	0.025	0.300	8.3–10.0	1
451–600	7000	0.030	0.020	0.200	8.3–10.0	0.5
601–750	7000	0.025	0.020	0.200	8.3–10.0	0.5
751–900	7000	0.020	0.015	0.100	8.3–10.0	0.5
901–1000	–	0.020	0.015	0.050	8.3–10.0	0.2
1001– 1500	–	0.010	0.010	0.00	8.8–9.6	0.2
1501–2000	–	0.010	0.010	0.00	8.8–9.6	0.2

Table 6. Recommended feedwater quality guidelines for water tube boilers (ASME 2013)

Boiler feedwater			
Drum pressure psi	Silica (SiO ₂) ppm	Total Alkalinity (CaCO ₃) ppm	Specific Conductance (micro-ohms/cm) (unneutralised)
0–300	150	700	7000
301–450	90	600	6000
451–600	40	500	5000
601–750	30	400	4000
751–900	20	300	3000
901–1000	8	200	2000
1001– 1500	2	0	150
1501–2000	1	0	100

Table 7. Recommended feedwater quality guidelines for water tube boilers (ABMA 2005)

Drum pressure psi	Total dissolved solids (TDS) ppm	Total alkalinity (CaCO ₃) ppm	Total Suspended Solids ppm
50–300	3500	700	15
301–450	3000	600	10
451–600	2500	500	8
601–750	1000	200	3
751–900	750	150	2
901–1000	625	125	1

Table 8. Maximum allowable impurities in boiler water quality from ABMA (2006)

Boiler feedwater				
Sodium sulphite (Na ₂ SO ₃) ppm	Sodium chloride (NaCl) ppm	Sodium phosphate (Na ₃ PO ₄) ppm	Sodium sulphate (Na ₂ SO ₄) ppm	Silica oxide (SiO ₂) ppm
1.0	10.0	25.0	25.0	0.20

Further reading

- AUS-MEAT, 2013, NFAS Rules & Standards (July 2013), AUS-MEAT Limited, Brisbane, Qld.
- DAFF, 2013, Australian Animal Standards and Guidelines for Cattle, Department of Agriculture, Forestry and Fisheries, Australian Government, Canberra, ACT.
- Adams, R.S, and W.E. Sharpe, 1995, Water intake and quality for dairy cattle, Penn State Extension, DAS 95-8, 7 pp. <http://extension.psu.edu/animals/dairy/health/nutrition/nutrition-and-feeding/water-and-water-quality/water-intake-and-quality-for-dairy-cattle/view>
- ANZECC, 2000, Australian and New Zealand guidelines for fresh and marine water quality: Volume 1 - The guidelines. Australian and New Zealand Environment and Conservation Council Agriculture and Resource Management Council of Australia and New Zealand – 2000.
- Case, AA 1957, Some aspects of nitrate intoxication in livestock. J. Amer. Vet. Assoc. 130:323.
- MLA, 2012a, National Guidelines for Beef Cattle Feedlots in Australia. Meat and Livestock Australia, Sydney, NSW.
- MLA, 2012a National Beef Cattle Feedlot Environmental Code of Practice. Meat and Livestock Australia, Sydney, NSW.
- EA Systems Pty Ltd 2004, Cooling Water for Lot-fed Cattle. Final Report FLOT.322. Meat and Livestock Australia Ltd, North Sydney.
- Willams, WD, Kenzie, OR, and TA McAllister, 2002, Effects of water quality on cattle performance. Journal of Range Management 55:452-460.
- Lofgreen, G.P., Givens, R.L., Morrison, S.R. and Bond, T.E. (1975). Effect of drinking water temperature on beef cattle performance. J. Anim. Sci. 40:233.
- EPA Water Quality Sampling Manual, 1999 and AS/NZS 5667.1:1998 Water Quality – Sampling for more detailed guidelines on groundwater quality sampling.
- Beede, D.K. 2006. Evaluation of Water Quality and Nutrition for Dairy Cattle, 2006 High Plains Dairy Conference, 24 pp. <https://www.msu.edu/~beede/dairycattlewaterandnutrition.pdf>
- Jones, GM and CC Stallings, 1999, Reducing heat stress for dairy cattle. Virginia Cooperative Extension.
- American Society of Mechanical Engineers, 2013, Boiler and Pressure Vessel Code 2013 edition. American Society of Mechanical Engineers.
- American Boiler Manufacturers Association, 2005, Boiler Water Quality Requirements and Associated Steam Quality for Industrial/Commercial and Institutional Boilers. ABMA-Boiler 402. American Boiler Manufacturers Association
- American Society of Mechanical Engineers, *Consensus Document on Operating Practices for the Sampling and Monitoring of Feedwater and Boiler Water Chemistry in Modern Industrial Boilers* (CRTD-81).
- American Society of Mechanical Engineers, 2013, *Consensus for the Lay-up of Boilers, Turbines, Turbine Condensers, and Auxiliary Equipment* (CRTD-66).
- American Society of Mechanical Engineers, 2013, *Practical Guide to Avoid Steam Purity Problems in the Industrial Plant* (CRTD-35).
- American Society of Mechanical Engineers, 2013, *Consensus on Operating Practices for the Control of Feedwater and Boiler Water Chemistry in Modern Industrial Boilers* (CRTD-34).
- Parish, J, 2009, Quality Water for Beef Cattle, Cattle Business in Mississippi – August 2009, “Beef Production Strategies” Mississippi State University
- Olson, O.E. and D.G. Fox. 1981. Great Plains beef cattle feeding handbook. GPE-1401. South Dakota State University. Brookings, SD.
- NRC, Nutrients and toxic substances in water for livestock and poultry, Washington DC: National Academy of Sciences, 1974.
- Rasby RJ, and Walz TM, 2011, Water Requirements of Beef Cattle, Beef Feeding and Nutrition, University of Nebraska.

- Marx, T, 2005, Water Requirements for Livestock, Agri-facts Agdex 400/716-1, Alberta.
- NRC. 1996. Nutrient requirements of beef cattle. 7th Rev. Ed. Nat. Acad. Press, Washington, DC.
- National Research Council. 1974. Nutrients and Toxic Substances in Water for Livestock and Poultry. Washington, D. C. National Academy of Sciences.
- Patience, J. F. 1994. Water quality and quantity: importance in animal and poultry 203 production. Biotechnology in the Feed Industry. Proc. Alltech's 5th Annual Symposium 204 pp. 121-138.
- Sparke EJ, Young, BA, Gaughan, JB, et al 2001, Heat Load in Feedlot Cattle MLA
- Stemmer, R.A, Brasington, CF, Coppock, CE, Lanham, JK and Milam, KZ 1986, Effect of Drinking Water Temperature on Heat Stress of Dairy Cows, Journal of Dairy Science Vol 69, Issue2, pp 546-551.
- Yousef, M.K., G.L. Hahn, and H.D. Johnson.1968. Adaption of cattle. In: Adaptation of domestic animals. E.S.E Hafez ed., Lea and Febiger, Philadelphia, p233- 245.



FEEDLOT DESIGN AND CONSTRUCTION

6. Energy sources and supply

AUTHOR: Rod Davis

Introduction

The feedlot production system is highly dependent on energy for equipment used to provide feed and water to livestock, manage waste (including pen cleaning, manure treatment and effluent disposal) and for administration and operation of the facility.

Energy sources are predominantly petroleum-based liquid and gas fuels and electricity from fossil or renewable sources. Energy prices are volatile but, as they generally rise over time, energy usage is an increasing input cost.

Infrastructure for energy storage and supply involve large capital and investment costs, and are long life assets. It must satisfy certain requirements that include an adequate storage volume, reliable and robust enough to resist disruptions (natural or human) and ideally, it should impose minimal environmental costs and security and safety risks.

Design objectives

Energy sources and supply systems should be designed and constructed to

- provide an adequate supply of energy for the feedlot's requirements
- have a redundancy supply capability in the event of loss or interruption
- be energy efficient
- comply with relevant acts and regulations
- protect against any environmental harm
- provide a safe working environment for all people.

Mandatory requirements

The installation and services for electrical and liquid fuel and gas must conform with the requirements of the latest issue of

- the local electricity supply utility's conditions of supply
- the local building regulations and the Building Code of Australia
- respective state and territory electrical safety acts and regulations
- respective state and territory acts and regulations for storage of flammable or combustible substances
- current Australian standards on electrical installations, services and cabling
- current Australian standards on storage of flammable or combustible substances.

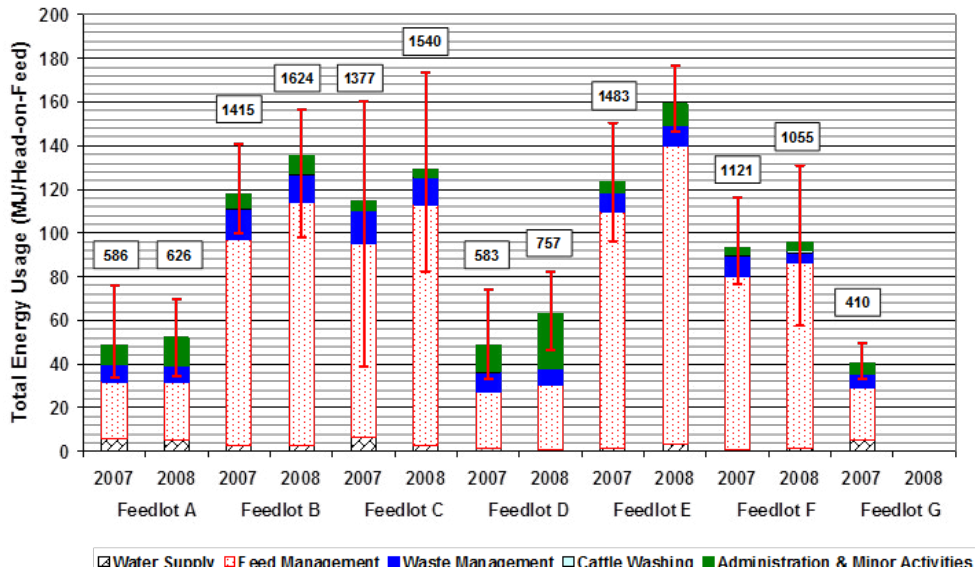

Figure 1. Average monthly total energy usage (MJ/head-on-feed/month).

Source: Davis et al. 2009

Design choices

Energy consumption

Energy consumption varies between feedlots depending on their size and levels of operational efficiency (Figure 1).

Total energy

Total energy usage within a sample group of Australian feedlots was measured from March 2007 to February 2008 (Davis and Watts 2006, 2009), along with the individual usage by water supply, feed management, waste management, cattle washing, administration and minor activities (cattle management and repairs and maintenance).

The average monthly total energy usage ranged from 40 MJ/month/head-on-feed to 124 MJ/month/head-on-feed. Feedlots with steam flaking averaged 100 MJ/month; those with grain tempering or reconstitution processing averaged 45 MJ/month/head-on-feed.

Energy for water

The energy usage for supplying water to the feedlot and for reticulation is a direct function of the system design (gravity or pumped), the pumping requirements (source of water and pumping head, distance), efficiency of the pumping system and power source (diesel or electric). The average monthly energy usage for water across all feedlots was 2.5 MJ/month/head-on-feed (0.04 MJ/month to 6.6 MJ/month). The total annual energy usage for water supply ranged from 12.3 MJ/year/head-on-feed to 77.7 MJ/year/head-on-feed.



Energy for water



Energy for feed processing



Energy for feed delivery



Energy for waste management



Overhead supply direct to on-site feed processing facility. This is located to avoid accidental contact with high machinery.

Energy for feed processing

The average electricity energy used for feed processing (excluding steam flaking) ranged from 20 to 50 MJ/tonne grain processed for seven feedlots. Variation in electricity energy usage may be attributed to monthly variation in grain delivery, movement, storage and milling efficiency (tonnes per mill). For steam flaking systems, the average gas energy usage ranged from 240 to 315 MJ/t grain processed, with some variation attributed to heating efficiency during winter months. Gas types included LPG, butane and natural gas.

Energy for feed delivery

At most feedlots, the energy usage for feed delivery totalled that for loading and for delivery.

The average monthly energy usage by loaders ranged from 7 to 22 MJ/t ration delivered, and depended on factors such as size of loader, bucket capacity, number of ingredients loaded and the other feed-related activities that the loaders may need to undertake. This may include transporting hay/straw from storage areas to tub grinders, silage from silage pits and high-moisture grain from storage areas.

The average monthly energy usage by feed delivery equipment ranged from 19 to 39 MJ/t ration delivered, and depended on factors including the number of trucks, volumetric capacity, engine capacity, commodity loading positions and pen layout.

Different feed mixing and delivery systems included stationary mixing, mixer/feed out trucks, bunker system, batch boxes and varying combinations in mobile equipment. Mobile equipment combinations included tractor/trailer mixer units, trucks with mounted mixers (various capacities and number, vertical, paddle and screw mixers), and varying loader sizes and number of ingredients loaded.

Energy for waste management

Typically, waste management contributes an average 14% of total energy usage (from 7% to 24%). Energy usage for waste management ranged from 6 MJ/head-on-feed/month to 15 MJ/head-on-feed/month with variation between feedlots attributed to the frequency of cleaning, equipment used and the volume of manure removed at each clean.

Energy sources

Electricity

Electricity is used to operate the various equipment, machinery and production processes.

The infrastructure associated with the electric power system includes supply side infrastructure such as overhead lines and transformers, equipment at the point of supply such as metering, switchgear and earthing, underground cable networks, feeder circuits, and switchgear associated with individual pieces of equipment.

Electric power is generally provided from overhead supply, but where there is no utility supply or the grid is not accessible, a prime power generator may be used. Power generators used as a primary power source (and not just for standby or backup power) can be defined as having an 'unlimited run time'. Prime generators are usually expensive in terms of capital and running costs.

Point of supply – overhead supply

One of the first determinations in the planning of a feedlot is the nearest point of supply from the local power authority. The local power authority will be able to provide information on supply options and costs, but will require information regarding on-site electrical demands.

Specialist advice regarding on-site electrical demands should be obtained from a designer (electrical engineer) suitably qualified and experienced in this area. Some of the variables can be single-phase or three-phase supply, peak demand versus average loading, and high voltage versus low voltage metering.

In a single-phase distribution system, all the voltages of the supply vary in unison. Single-phase distribution is used when loads are mostly lighting and heating, with few large electric motors. Single-phase motors need additional circuits for starting and are rarely larger than 10 or 20 kW in rating. Single phase line connections are generally available for small domestic requirements.

Three-phase electric power is used to power large motors and other heavy loads and is the most common requirement for feedlots. A three-phase system is usually more economical than an equivalent single-phase at the same voltage because it uses less conductor material to transmit electrical power.

In many country areas, a single-wire, earth-return (SWER) line may be the connection. SWER delivers single phase power and is an economical way of distributing power because it needs only one transmission line (active). There is no neutral – instead, the earth is employed as the 'return' conductor. If three-phase motors have to be used, a single-phase to three-phase power converter has to be installed.

The location of the supply metering dictates the way in which the feedlot will be charged for its electric power usage. With high-voltage metering, the power usage is measured on the input side of the step-down transformer (usually at 11,000V). The feedlot will have to purchase and own the step-down transformer but this form of metering generally results in cheaper power costs. Low-voltage metering is carried out after the transformer (usually at 415 volts) and in this case the transformer is supplied and owned by the supply authority.

Electrical meters and metering

All sites that use electric power will have power authority electricity meters. The most common unit of measurement on the electricity meter is the kilowatt hour, which is equal to the amount of energy used by a load of one kilowatt over a period of one hour, or 3,600,000 joules (3.6 MJ).

The most common type of electricity meter is the Thomson, or electromechanical induction watt-hour, meter.

Some newer electricity meters are solid state and display the power used on an LCD or can be read automatically. The solid state electricity meter may be able to display several different measurements, including voltage or current in the circuit and display the energy usage in each of the three phases separately or as a total.

Electrical energy can be metered by direct metering or current transformation metering.



Overhead electricity – supply with aerial transformer and sub-board



Overhead electricity – supply pole and transformer



Power Authority meter – solid state with LCD display



Power authority meters: electromechanical induction-rotating disc meter, with one meter for each phase

Typically, direct metering will be used in applications requiring less than 100 amps. Electromechanical or digital power meters are installed at the switch board with a separate meter for each phase. Hence, three-phase applications will have three meters.

In many feedlots, line currents may range from small to relatively large, such as in 150 A, so that the size of the conductor to measure the range and to produce an appropriately scaled output becomes prohibitive. In such instances, a current transformer is typically employed in conjunction with the electrical meter and the internal current sensing device of the meter. Conventional current transformers create a scaled output current, proportional to the line current which is supplied to the electrical load. The output current is sensed by the electrical meter and the power consumption of the associated electrical load is measured. Therefore, the transformation ratio (e.g. 80/5, 100/5) needs to be known to calculate the actual power usage.

Metering electricity at various points across the site is strongly recommended to provide data for energy efficiency assessments and management.

Network tariffs

Network tariffs are currently regulated by the Australian Energy Regulator. There are two main tariff components to an electricity bill

- retail component – to recover the purchase cost of energy from the generator
- network component – to recover the network costs (both distribution and transmission) of delivering energy to the site. This is a regulated charge levied by the distribution businesses to which the customer is connected, and by the transmission company that owns the transmission assets.

Retailers and transmission companies vary with each state and territory. In all except Victoria, electricity prices - the 'standing offer' tariff - are fixed by independent regulators. The WA and NT Governments directly regulate retail electricity prices while the Queensland Government can vary the regulator's pricing decisions.

Each retailer has various network tariff classes to which all customers are assigned. The type of network tariff class will depend on facility location, power consumption, use and time of use.

Victoria, Tasmania, NSW and Western Australia have introduced some form of kVa or power factor network tariff. The power factor is a measure of how effectively electrical power is being used by a system. A poor power factor indicates ineffective utilisation of electricity; a good power factor indicates effective electricity and asset utilisation. Enterprises should understand the implications of their power factor and power factor correction when negotiating supply contracts. Power factor correction devices can be installed next to large electricity consumption plant such as feedmills, and these devices will improve the power factor and hence the efficiency of power usage.

It is recommended that specialist advice on network tariffs should be obtained from a suitably qualified and experienced person.

Safety

Unsafe use of electricity and accidental contact with overhead powerlines are common causes of injuries and death. Electricity can jump gaps so a person or piece of machinery may be some distance from a powerline and still be in danger.

Safe clearance distances should be maintained from overhead powerlines for structures (buildings, and stacked farm material), machinery (spray equipment, mobile elevators and mobile machinery) and vegetation. Safe clearance distances depend on the voltage and the type of powerline conductors (wires and cables). As overhead powerlines swing in wind and sag when hot, this movement must be considered in any clearance distance. The various state electricity acts prescribe a range of safe clearance distances.

Photovoltaic systems (Solar energy)

The installation of a photovoltaic (PV) system (either stand-alone or grid-connected) may be used to meet all or part of the electric power demand of a facility. Whether a PV system will be viable depends on the power demand and cost of supply of more conventional sources of energy. PV systems can be used in a wide variety of applications and are commonly suited for stand-alone applications at relatively isolated sites e.g. water pumping.

The design of a PV system needs to be realistic and flexible, and not be over-designed or the energy requirements overestimated (e.g. overestimating water pumping requirements). This will increase the cost of the system while not all the power available can be used. Dust and heat can be a problem with PV units located at feedlots. PV systems operate at their peak efficiency at 25°C, and their generation efficiency decreases as the temperature of the unit rises above this. In hot climates it may be necessary to cool the units with water sprays. Similarly dust from feedlot activities can coat PV cells and reduce their ability to generate electricity. If the PV cells have been installed at the correct angle to the horizontal, regular washing with water will remove the dust, and permanently installed water sprays operating on a timer can resolve both heat and dust problems. However, the water used must be free from salts that can coat the surface of the panels and reduce their productive capacity.

Since a PV system can generate electricity only when the sun is shining, some provision (e.g. battery bank or grid connection) must be made to have electricity supply during cloudy weather and at night, if required.

Every installation must be carried out by an accredited installer to meet the relevant Australian standards.

Backup electric power supply

Backup generators are a common and effective way of protecting a feedlot against the economic, social and animal welfare consequences of electric power disruptions. Most backup generators run on diesel but gas (natural, liquid propane)-driven generators are also available. The ability of a backup generator to provide continuous power, as long as it has a supply of fuel, makes it well-suited for providing both long- and short-term power. As backup power generators typically



Diesel engine-powered backup generator housed inside shed



Self-contained backup generator on skid-mount

work for short durations and do not heat up as much as prime generators, they are generally fitted with smaller cooling systems. Some small-capacity standby power generators can be air-cooled, eliminating the need for water circulation.

The purpose of the generator must be clear before purchase, and it must be adequately designed and sized to cover the power needs of designated loads. Initially, a generator may be chosen for standby usage only. However, if power outages occur frequently or for long periods, it might be worth the extra investment in a prime or continuous-rated power generator to ensure uninterrupted supply of backup power for extended periods of time.

Operating standby generators for longer than the prescribed number of hours at one time is likely to lead to more frequent breakdowns and malfunctions.

All standby generators are designed to automatically provide power to designated loads in the event of an interruption in service. When power is lost, the generator automatically starts and the load is automatically transferred from utility company power to the generator. Once utility company power is restored the load is transferred back and the generator shuts down.

While generator systems are reliable, they are not maintenance-free and require regularly scheduled maintenance to perform as and when needed. The specific testing and maintenance procedures for generator units will vary in accordance with the make, size and operating conditions; however as a guide, generators should be tested at least once a week. The most important maintenance task is the regular exercising of the entire system. The generator should be run under the load that it would normally power for at least 30 minutes at each test. By operating the system under load, the generator is tested along with its starting system, cooling system, and all switchgear required to supply power to the loads.

In addition to the program of regular exercising, other routine maintenance tasks must be performed. The batteries used to start the generator should be checked monthly. Each time the generator is run or exercised, the fuel supply should be inspected to determine how much is present and to ensure that it is free of contamination. The cooling and exhaust systems should be inspected monthly.

Sizing

Proper sizing of the generator is crucial to the success of any installation. This requires a good working knowledge of electricity and its characteristics as well as the varying requirements of the electrical equipment comprising the load.

The electrical load must be analysed to determine total starting and running requirements in terms of watts, amps and voltage. It may be cost effective to have more than one generator, either in a bank or located alongside various power-using operations.

Typically, kVA is used as the primary value when referencing the output power of generator sets. The primary difference between kW (kilowatt) and kVA (kilovolt-ampere) is the power factor. kW is the unit of real power and kVA is a unit of apparent power (or real power plus re-active power). The power factor, unless it is defined



Main power supply - switchboard arrangement with switchover to backup generator

and known, is therefore an approximate value (typically 0.8) and the kVA value will always be higher than the value for kW. The standard power factor for a 3-phase generator is 0.8.

Generators with higher power factors transfer energy more efficiently to the connected load, whereas those with a lower power factor result in increased power costs.

Typically, the generator output for industrial applications should be selected at approximately 25% higher than the peak load. For example, if the load is about 40 kVa, select a 50 kVa generator. A higher-rated generator will operate comfortably at approximately 80% of its full capacity, and will provide a margin of flexibility if the load increases in the future.

Before installing a generator check for local authority codes that may dictate requirements regarding placement of the unit e.g. set back from building, electrical wiring, gas piping, fuel storage for gas or diesel tanks, sound and exhaust emissions.

For compliance with various state and national electrical regulations and for safety reasons, the backup power system must be installed, serviced and repaired by a qualified electrician who is familiar with applicable codes, standards and regulations.

Electrical services and cabling

Electrically powered equipment needs an appropriate power supply with switchboards, distribution boards, associated switchgear and cabling. Each control, switch, main switchboard and distribution board should be clearly labelled. All switchboards and distribution boards should be designed to be vermin proof with lockable doors.

All the cables should be installed on a cable ladder, in conduits or internal to walls or structure. Cables themselves must not be supported from roof structures nor left unsupported. Relevant standards must be put in practice in relation to cable supports.

All underground electrical services must be installed in accordance with the requirements of AS 3000. Layouts of underground services with quantity and size of cables and conduits should be marked and recorded accurately. Underground cable routes are to be marked with manufactured cable markers indicating the presence of underground cables.

Distribution boards should be located near electricity usage points so that the length of connection cable is kept as short as possible to reduce line losses.

All electrical installations must be carried out by an appropriately licensed electrical contractor.

Liquid fuels

Liquid fuel (diesel, petrol or gas) is required for mobile machinery and for some stationary plant. *Section 38 – Fuel and gas storage* details requirements for storage of these various fuel types.



Banked LPG storage tanks – with bollard protection



Diesel and petrol fuel storage with bowlers. Bunding behind and to each side of the facility is effective against spills; however it could fill with water after rain and has to be drained.

Renewable (bio) energy

There are four potential processes of energy recovery from biomasses such as feedlot manure. These include

Combustion

Combustion is the thermal reaction of oxygen with the carbon, hydrogen and sulphur in a fuel or solid waste yielding heat energy with the principal products of combustion being carbon dioxide, water and sulphur dioxide. When combusting sludge or manure, the amount of water (moisture content) and combustible material (volatile solids) present in the waste will significantly influence the quantity of usable energy which can be generated by the combustor or in fact, the amount of auxiliary fuel required to complete the combustion process.

There are currently no commercial facilities combusting feedlot manure in Australia but research and pilot-scale combustion trials have been conducted around the world. Research (Watts et al. 2013) has been conducted by MLA in this area.

Gasification

Gasification is a thermal process where a small portion of the waste (typically 5–15%) is combusted under starved air combustion conditions to raise the waste material to a temperature of about 900°C. The end products of gasification are a syngas comprising mainly carbon monoxide, hydrogen and carbon dioxide and an ash or char product, depending on operating temperature. Typically, gasification processes use air, oxygen and/or steam.

There are currently no commercial facilities gasifying feedlot manure in Australia. The high silica and ash content of feedlot manure means that existing biomass gasification systems may be of limited use. Gasifiers specifically designed to handle feedlot manure need to be developed with turnkey commercialisation if adoption is to occur within the industry.

Conventional gasifiers appear to be of limited use for the processing of feedlot manure.

Pyrolysis

Also called carbonisation, pyrolysis is universally regarded as a process where waste is heated indirectly, in the absence of oxygen, to a temperature of between 350 and 500°C. Under these thermal conditions the waste decomposes and 30–60% of the dry mass is volatilised to produce a crude syngas, with the remaining solids converted to a char product. In essence, pyrolysis is the thermal destructive distillation of organic materials.

Anaerobic digestion (Biogas)

Anaerobic digestion is a process that decomposes organic material (i.e. volatile solids) in the absence of oxygen. The mineralisation process is completed by microbial consortia composed of hydrolytic and fermentative bacteria as well as acetogens and methanogens. Bio-gas (CH₄) and CO₂ are produced as a waste product of digestion.

Research is also currently being conducted by MLA in this area. A few feedlots in the USA have installed anaerobic digestors.

Quick tips

- Determine available connection (e.g. single-phase, three-phase) of electric power from local power authority when planning a new development or upgrading an existing facility.
- Seek professional assistance when negotiating electric power supply contracts.
- Renewable energy systems such as solar or wind may be viable depending on the power demand and cost of supply of more conventional sources of energy. No bioenergy processes have yet been shown to be viable at Australian feedlots.
- Conduct a power supply risk assessment to determine contingency options for interruptions and/or loss of electric power.
- Generators are a common and effective way of protecting a feedlot against the economic, social and animal welfare consequences of electric power disruptions. Most backup generators are powered by diesel engines and should be checked every month.
- Obtain and keep a record of line diagram schematics and ratings of switchgear and cables of the electric power system.
- Record and keep layouts of underground services with quantity and size of cables and conduits.
- Installing meters for electricity and liquid fuel throughout the feedlot allows data to be collected for assessing energy efficiency.

Further reading

Standards Australia, 2009, Electrical Installations – Australian and New Zealand Wiring Rules (AS/NZS3000:2007), Sydney, NSW, Standards Australia.

Standards Australia, 2009, Electrical Installations - Selection of Cables - Cables for Alternating Voltages up to and including 0.6/1 kV (AS/NZS3008.1.1:2009), Sydney, NSW, Standards Australia.

Standards Australia, 2001, Conduits and Fittings for Electrical Installations (AS/NZS 2053-2001), Sydney, NSW, Standards Australia.

Standards Australia, 2004, The storage and handling of flammable and combustible liquids (AS1940-2004), Sydney, NSW, Standards Australia.

Standards Australia, 2006, Steel tanks for flammable and combustible liquids (AS1692-2006), Sydney, NSW, Standards Australia.

Standards Australia, 2006, Steel tanks for flammable and combustible liquids (AS1692-2006), Sydney, NSW, Standards Australia.

Standards Australia, 2007, Lightning protection (AS 1768-2007), Sydney, NSW, Standards Australia.

Standards Australia, 2012, Installation and safety requirements of photovoltaic (PV) arrays (AS/NZS 5033-2012), Sydney, NSW, Standards Australia.

Davis RJ and Watts PJ (2006), Environmental Sustainability Assessment of the Australian Feedlot Industry, Part B: Energy usage and Greenhouse Gas emissions at Australian Feedlots Project FLOT.328B, Meat and Livestock Australia Ltd, North Sydney, New South Wales.

Davis RJ, Wiedemann SG and Watts PJ (2009), Quantifying the Water and Energy Usage of Individual Activities within Australian Feedlots, Part B Report: Energy Usage at Australian Feedlots 2007-2009, Project FLOT.0350, Meat & Livestock Australia Ltd, North Sydney, New South Wales.

Watts, PJ, Bridle, T, McGahan, EJ and Ni Cheallaigh, A, 2013, Thermal Energy Recovery from Feedlot Manure – Pilot Trials, Project FLOT.0368, Meat & Livestock Australia Ltd, North Sydney, New South Wales.



FEEDLOT DESIGN AND CONSTRUCTION

7. Site investigations

AUTHORS: Peter Watts and Rod Davis

Introduction

Feasibility studies, planning, design and construction all require reliable and relevant data about the ground conditions of a potential site.

A site investigation is the overall process for the collection of information, appraisal of data, assessment and reporting.

This data must be gained competently, in a timely manner and to a degree which is adequate and appropriate to each stage of design and development. In this way risk and liability are minimised, the potential for economic and safe design is maximised and the project is more likely to be completed on time and within budget.

Inadequate site investigations may lead to the wrong choice of design, incorrect dimensioning, inadequate foundation solution, encroachment on neighbouring properties or easements (road reserves, pipelines, overhead supply lines), ill-judged or dangerous execution of ground construction work as well as damage to neighbouring buildings or other structures. The economic cost can be enormous.

The approach to be adopted for a particular site investigation, its extent and the techniques used will all depend upon the site-specific circumstances, and the experience and judgement of those involved.



RTK-GPS is commonly used survey equipment.

Design objectives

Site investigations should be conducted and managed to ensure that

- the design requirements are understood
- the lot feeder understands the importance of having an accurate knowledge of the site and sub-soil conditions
- competent advice is obtained from appropriately qualified personnel with relevant experience
- physical investigations are conducted to collect all relevant samples and data required for design and construction (e.g. geotechnical, environmental, topographic constraints)
- natural and manmade features are accurately recorded
- in-situ soils are adequately characterised.

Mandatory requirements

Conduct a 'Dial Before You Dig' search before any below-ground investigations at a site. This request is for plans of underground services at the location in which any ground penetration works are intended. The request will be referred to the relevant underground asset owners who will then forward plans of underground services, such as power cables, water and/or gas pipelines, and communication cables located on the site.

Design choices

There is no single way to carry out a site investigation and inevitably different approaches will be adopted for any particular development. The process of collection of information, appraisal of data, assessment and reporting will most likely be staged. The various stages for a site investigation include

Desktop study

A desktop study is one of the most valuable and cost-effective elements of a site investigation. At this stage the site is not visually appraised but a search is instigated for any information concerning the site, such as its environmental constraints, land resources, any previous investigations, former uses, any history of performance and any features in the area which may have influenced the site or which the proposed development may influence.

Information may be obtained from various sources such as maps and published documents, aerial imagery e.g. aerial photos, Google Earth, survey plans, state planning policy searches, online resources and from interviews and contacts.

In this stage, a preliminary assessment of the site's suitability can be assessed. For example, details about past and present land use, natural resources, geology, surface and groundwater environment, cultural heritage, archaeological values, contaminated land status and land use restrictions that may be relevant to the proposed development can be taken into account for future planning of the project.

Several sites can be evaluated in this way at minimal cost.

Site survey

Surveying is a process for accurately determining the placement of natural and manmade features of a site.

Typically, the survey consists of establishing controls (bench marks), recording natural surface features, terrain of the location and any manmade features of significance. Generally, at least two surveys— a preliminary survey and a construction set-out survey— are required before construction can start.

Preliminary survey

A preliminary survey may include one or more of the following activities

Cadastral survey – A cadastral or boundary survey locates the exact boundary of the property or lease area. A boundary survey will also show easements for utilities such as water, sewer, powerlines and telecommunication lines and identify any encroachments such as roadways, fences or buildings. For greenfield or brownfield sites, a boundary survey is important to ensure that the construction is done on the correct area of land.

A cadastral survey should be carried out by a suitably qualified land surveyor who is licensed to perform in the relevant state.

Feature and topographic survey – A feature and topographic survey details all information about the site. It is used to determine and locate the natural and manmade features and improvements on the site. This survey is used by designers to collate factors such as

- ground level and contours
- existing structures
- adjoining structures
- fences
- utility services



Permanent survey mark (PSM) and marker post.



The PSM should be accessible by GPS and able to have tripod mounted above it.



RTK-GPS survey base station and rover mounted on ATV

- drains
- trees
- drainage lines.

This can be important at existing feedlot sites where poor records are available, particularly for features such as water pipelines. The information is useful in determining the degree of ‘cut and fill’ required in the preparation of the feedlot site.

Control marks

Survey marks called bench marks (BM) for vertical and horizontal control should be installed. These can be temporary (TBM) or permanent survey marks (PSM) but should be sited in an area where they are least likely to be disturbed or removed during the construction phase of the project. They also need to be accessible for GPS units and to mount a tripod over. Further surveys can be based upon these benchmarks. Installing several benchmarks will allow for redundancy if some are destroyed during construction.

Vertical control determines the elevation with respect to sea level or a level reference surface or datum from a known PSM, and is used to accurately coordinate vertical positional data for ‘cut and fill’ earthwork operations. The datum (vertical level) of the bench mark system is taken from the PSM (Australian height datum - AHD - if known) or an arbitrary datum. Horizontal datum may be arbitrary or MGA 94.

Construction set-out survey

A set-out survey is used to transform the engineering design with precision accuracy onto the exact position at the site, and is important when preparing for any type of construction work.

A set-out survey involves transferring a design onto the land itself so the construction contractors can follow it during construction. During the process, key points are established and markers used to guide the construction process and ensure accuracy. The contractor may have individual preferences set-out (e.g. centreline versus embankment toe) and therefore should be consulted.

Survey techniques

Modern equipment such as Total Stations (which are basically electronic theodolites with built-in electronic distance meters) and GPS are used to measure and capture data that will later be downloaded into mapping software.

Real Time Kinematic (RTK) satellite navigation is a technique used to enhance the precision of position data derived from satellite-based positioning systems, being usable in conjunction with GPS. RTK-GPS is being becoming increasingly used for large detail and contour surveys as well as a variety of other engineering applications.

RTK-GPS systems offer a typical nominal accuracy of less than 1 cm horizontally and vertically. However, RTK-GPS requires a clear view of the sky with no obstructions from about 5 degrees elevation and up. GPS surveying under trees or near buildings results in reduced accuracy. Hence, TBMs must be located carefully.



A poorly located Temporary Bench Mark (TBM) sited near to infrastructure not affected by earthworks.

A total station may not be able to see a target on this TBM from all directions. RTK-GPS accuracy may also be reduced as the pole may screen satellite location.

As machine guidance is now a widely adopted technique in earthwork operations due to its accuracy and ease of use, survey data may be integrated into the construction contractor's equipment. The engineering design data can be transferred (imported) into GPS machine guidance systems. RTK-GPS-based machine guidance systems require input data from a 3D model of the existing and planned surfaces topography, to allow correct horizontal and vertical control.

Light Detection and Ranging (LiDAR) is an aerial survey technique that is often used to capture large survey areas in a relatively short period of time.

The process works by measuring the time taken for light to travel from a transmitter located on the aircraft to the ground and back to the receiver. As long as the light source can make contact with a surface, the corresponding height can be recorded. This allows the survey to penetrate through light to medium vegetated areas but not extremely dense vegetation or solid structures such as a shed roof.

After completion of the aerial survey, data is mathematically modelled to determine the ground surface. Where a solid structure is encountered, the underlying ground surface is interpolated using the surrounding points.

In order to tie the survey points to a horizontal and vertical datum, several control points are located around the boundary of the flight path. These control points are captured during the aerial survey and are captured again by ground surveyors. Similar to the RTK-GPS process, benchmarks should also be installed on the site so that follow-up ground surveying can be tied back into the previous data.

A common vertical accuracy for LiDAR surveying is 0.1m, but the level of accuracy can change depending on what is required. To guarantee quality results, LiDAR has to be undertaken in favourable weather conditions (day or night) when there is no rain and minimal cloud coverage.

Geotechnical investigations

Geotechnical investigations obtain information on the physical properties of soil, rock and/or shallow groundwater around a site to assess suitability of material for construction and to allow accurate design of earthworks and foundations.

The most common methods of observing the soils below the surface, obtaining samples and determining physical properties of the soils and rocks include

- excavation of test pits/trenches using a backhoe and various sized excavators
- hand augers
- drilling/boring, i.e. rotary, hollow-stem auger, continuous-flight auger.

Test pits/open cuts have the advantage of displaying the soil profile more clearly. The soil should be laid out around the test pit in the order of extraction so that the profile can be described accurately and appropriate samples taken for subsequent laboratory testing. Test pits and open cuts are usually 3–5m in depth but this depends on the size of the equipment being used and design requirements.



Test pit excavation. Separate the soil horizons or changes in soil texture during excavation to allow soil samples to be collected from each type of material encountered.



Excavated test pit illustrating changes in soil texture down the profile.

The test pit or bore hole should extend at least 0.5 m below the anticipated earthworks cut or pile depth.



Shallow groundwater intersected during excavation.



Soil sampling rig using spiral auger



The soil sample should be taken straight off the auger and its depth recorded.

For safety reasons, no one should enter an unstable pit.

Drilling augers tend to mix the different layers of the soil profile together and may not be suited for all applications.

Evidence is sought of natural groundwater seepage (e.g. springs). In extended dry periods, local knowledge should be used to determine if any springs may break out in wet weather.

If water is encountered during investigations, its depth should be recorded. Rising water levels should also be noted as they tend to indicate the presence of pervious layers that should be investigated further before construction.

If rock is encountered during investigations, study and record the type of rock, its condition (i.e. cracked, jointed or weathered) and its depth. The presence of rock can pose problems during construction and can also provide 'seams' along which water might escape in the construction of a dam.

Geotechnical investigation should be undertaken in accordance with AS1726 – Geotechnical Site Investigations. Collection of information and its appraisal should continue during the construction works to confirm the geology and soil types of the proposed feedlot site.

Typically a geotechnical investigation is undertaken by a suitability qualified and experienced geotechnical engineer or a company specialising in geotechnical investigations.

Location of test pits

The approximate location of test pits over the proposed construction site should be decided before the site visit, based on information from soil maps and the probable location of all earthworks plus potential borrow pits. Test pits or boreholes will characterise the variability and extent of on-site soils, and could look at locations that may also contain material suitable for the construction of pen and road surfaces (e.g. gravel) and/or sand for concrete, and clay for embankments.

Once completed, the test pits should be photographed and their locations marked on a site plan for future reference; GPS units provide a quick and accurate method for marking test pits and other locations.

The location of each borehole or test pit should be accurately surveyed and recorded to assist when comparing relative levels (RL) and slope grades to those expected in the subject landscape. The expected accuracy (ie. \pm x metres) of the GPS or survey equipment used should also be recorded.

Soil sample collection

Depths of soil layers and descriptions using the nomenclature of the Australian Standard for 'Geotechnical site investigations AS 1726 – 1993', should be logged for all soil types encountered. Particular attention should be paid to the description of soil consistency and structure and if encountered, any auger refusal on shallow rock. Shallow water tables and the presence of fill should be noted.

The size of the sample should be based on the number and type of tests to be performed.

Table 1. Unified Soil Classification System (Standards Australia 1993)

Major divisions			Group symbol	Group name
Coarse grained soils more than 50% retained on No. 200 (0.075 mm) sieve	gravel > 50% of coarse fraction retained on No. 4 (4.75 mm) sieve	clean gravel <5% smaller than No. 200 sieve	GW	well graded gravel, fine to coarse gravel
			GP	poorly graded gravel
		gravel with >12% fines	GM	silty gravel
			GC	clayey gravel
	sand ≥ 50% of coarse fraction passes No. 4 sieve	clean sand	SW	well graded sand, fine to coarse sand
			SP	poorly-graded sand
		sand with >12% fines	SM	silty sand
			SC	clayey sand
Fine grained soils more than 50% passes No. 200 (0.075 mm) sieve	silt and clay liquid limit < 50	inorganic	ML	silt
			CL	clay
		organic	OL	organic silt, organic clay
	silt and clay liquid limit ≥ 50	inorganic	MH	silt of high plasticity, elastic silt
			CH	clay of high plasticity, fat clay
		organic	OH	organic clay, organic silt
Highly organic soils			Pt	

Laboratory tests

Soil samples collected during site investigation are usually preserved and protected against any possible disturbance or moisture changes and sent to a soil testing laboratory for determination of various geological and engineering properties. The following engineering tests are recommended on the collected soil samples

- Engineering classification of soils (USCS classification); see Table 1
- Liquid limit, plastic limit, plasticity index tests and linear shrinkage to classify fine-grained soils (clays and silts) and other geotechnical correlations
- Particle size analysis (by sieve analysis for coarse-grained fraction of soils, by hydrometer test for fine-grained fraction of soils)
- Optimum moisture content (OMC) and maximum dry density (MDD)
- Soaked CBR value for pen surfacing and/or road material
- Hydraulic conductivity for pen and pond lining material
- Slaking and dispersion – Emerson class number. Slaking and dispersion is a structural stability indicator and is important from the perspective of embankment stability and erosion.

A materials quality test should be conducted in accordance with relevant Australian Standards, as detailed in Table 2.

Table 2 – Recommended engineering tests for soil samples

Test	Australian Standard
Engineering Classification - USCS	AS1726
Particle size distribution (grading)	AS1152
Soaked CBR Value	AS 1289.6.1.1-1998
Liquid Limit	AS 1289.3.1.1-2009
Plasticity Index (PI)	AS 1289.3.3.1-2009
PI × % Passing 425µm Sieve	AS 1289.3.3.1-2009
Emerson Class Number	AS 1289.3.8.1
Linear Shrinkage (LS)	AS 1289.3.4.1
LS × % Passing 425µm Sieve	AS 1289.3.4.1
Dry Density/Moisture content relationship	AS 1289.5.2.1-2007
Dry Density Ratio	AS 1289.5.4.2-2007
Optimum Moisture Content (OMC)	AS 1289.5.4.1-2003
Hilf Density Ratio	AS 1289.5.7.1-2006
Hydraulic Conductivity	AS 1289.6.7.1; AS 1289.6.7.2; AS 1289.6.7.3.

These recommended engineering tests are used to determine the soil properties required for each material used in

- pen and road surface construction, and composting and/or stockpiling areas; see *Section 17 – Pen and road surfaces*
- clay liners for holding ponds and sedimentation basins; see *Section 12 – Holding pond design*

If a sample fails any of the preliminary tests for the intended use, the material represented by the sample should be rejected as unsuitable for the intended works.

Further information of material suitability for pen foundations and pond construction can be found in *Section 17 – Pen and road surfaces* and *Section 12 – Holding pond design*.

Laboratory testing should be conducted by a company specialising in soil testing and with National Association of Testing Authorities, Australia (NATA) accreditation for the relevant tests to be performed.

Common site problems may include

- excavation walls caving in
- drilling difficulties
- loss of sample during retrieval
- knowing when to stop a hole, or what and when to test and sample
- misidentification of samples and sampling locations
- breakdown and breakage of equipment
- environmental impacts of construction activities on wildlife, vegetation, waterways and inclement weather
- working close to earthmoving equipment, trucks and overhead loads
- hazards encountered when undertaking ground penetration.

Safety

Activities associated with site investigations must comply with WHS and environmental management requirements which may be imposed through state/territory or federal legislation.

Activities must adhere to state/territory or federal legislation. However, as a general guide

- Barricades at least 900 mm high must be erected around a trench that is 1 m or more deep unless it is not possible or if only workers involved with the trench will be in the area, or another form of barrier exists e.g. excavated materials near the trench.
- Check whether trenches can be left open for future inspection by engineers/contractors or need to be refilled immediately.
- If a person is entering a trench more than 1.5 metres deep, it must be either
 - shored or shielded
 - benched – not higher than it is wide and no vertical face exceeding 1.5 metres
 - battered – angle not exceeding 45° and bottom vertical face not exceeding 1.5 metres
 - approved in writing by an engineer as safe to work in.
- Ladders used for access must be no more than 9 metres apart in the area of the trench where work will be carried out.
- Temporary fencing suitable to exclude livestock should be installed to prevent livestock falling in trenches.

Ground penetration works that are generally exempt from WHS and 'Dial before you dig' considerations include

- using machinery or power tools to dig less than 150 mm deep
- digging less than 300 mm deep without machinery or power tools
- emergency excavation to mitigate death or prevent injury.

Geotechnical investigations, and to a lesser extent surveying, involve activities that will penetrate into the ground and potentially cause problems by encountering unseen objects.

Hazards include penetration of

- gas pipes
- water supply lines
- buried electrical cables
- buried communication cables
- any other buried utility infrastructure.



Safety barrier placed around excavated pit



Check for underground water pipes and electrical and communication cables.

"Dial before you dig"

Water supply and quality

Surface water and/or groundwater for the feedlot water supply should be evaluated with water samples collected from the intended supply to assess quality. Bores may need to be tested to determine yield and flow rate.

All tests should be carried out to the Australia Standard Code of AS2368-1990 – Test Pumping of Water Wells by a company specialising in bore flow testing and reporting.

Good quality water is clean, clear, odourless and without a high mineral content. Water quality is lowered by soluble salts, algae, pollution (e.g. dead animals, bird faeces or debris) and clay (in suspension). See *Section 5 – Water quality*.

Water samples collected during the site investigation must be preserved and sent to a water testing laboratory to determine water quality. Water quality is generally assessed on

- physical properties
- physiochemical properties – physical properties and chemical composition including salinity, hardness, and pH
- excess nutrients – excessive levels of nitrates can affect cattle health
- toxic compounds – heavy metals and fluoride can pose a health hazard to cattle
- microbiological agents – for example, faecal coliforms and cyanobacteria (blue-green algae).

See *Section 4 – Water requirements* and *Section 5 – Water quality* for more information on water quality guidelines.

Always seek advice from a suitably qualified and experienced animal health practitioner (e.g. nutritionist and/or veterinarian) to confirm the suitability of the water for the feedlot drinking water supply.

Electricity supply

The electrical power supply to the site should be confirmed by on-site inspection and through enquiries with the local utility provider. Evidence of the capacity and number of power supplies to the site should be sought. It can be useful to record pole numbers for discussion with power authorities.

Environmental

The following data should be collected to identify any potential constraints should a surface water body, wetland or significant vegetation be present on the site

- distance to the surface water body, wetland or significant vegetation
- site drainage patterns
- likely location where the contaminants of concern from the site may discharge into the surface water body or wetland
- flow direction and depth of any groundwater that potentially could be contaminated in relation to such water body or wetland
- classification of the water body.

The site should be searched to assess any potential contaminated land issues as a result of current and past practices on the site.

For example

- cattle yards, and in particular old dips, may have pesticide residues
- inhabited or uninhabited buildings or workshops may have potential impacts from fuel storage, pesticide use and asbestos.

Quick online searches to assess a site's suitability should be carried out when conducting site investigations. These searches should investigate the environmental constraints, land and water resources and cultural heritage aspects of the site. The websites used should be specific to the region in which the site is located. Searches should include

- climate
- bushfire risk
- flood hazard area
- landslide hazard area
- strategic cropping land
- good quality agricultural land
- agricultural land classifications
- contaminated land register
- acid sulphate soils
- surrounding mine and extractive resources
- energy and water supply or underground facilities
- vegetation mapping
- environmentally sensitive areas
- wetlands
- cultural heritage
- national heritage places.

The type and distance to sensitive receptor sites should be confirmed on-ground.

Quick tips

- Conduct a preliminary desktop assessment of the site's suitability (e.g. about past and present land use, natural resources, geology and the surface and groundwater environment). Several sites can be evaluated in this way at minimal cost.
- Undertake a site investigation to identify and record design constraints of the site. During the site investigation, topographic limitations should be noted e.g. slope gradients, flood inundation lines, rock outcrops, vegetation coverage (shrubby and larger trees), surface waters, groundwater and sensitive receptors.
- A site survey should establish vertical and horizontal control marks, record natural and manmade features and surface elevations.
- Check with construction contractors to ensure that survey and design data can be seamlessly integrated into machine guidance equipment.
- Obtain information on the physical properties of soils around a site to design earthworks and foundations and assess suitability of material for construction.
- Record the locations of test pits and bore holes.
- Check the suitability of nearby water supplies for cattle drinking.

Further reading

Dial Before You Dig - www.1100.com.au

Standards Australia (1993) AS 1726 - Geotechnical site investigation. Standards Australia, Canberra

Standards Australia 1999, AS 1289 Soil Testing for Engineering Purposes. Standards Australia, Canberra.

Standards Australia, 2005, AS 4482.1-2005, Australian Standard: Guide to the Sampling and Investigation of Potentially Contaminated Soil. Part 1: Non-volatile and Semi-volatile compounds. Standards Australia, Canberra.

Standards Australia, 1999, AS 4482.2-1999 Australian Standard: Guide to the Sampling and Investigation of Potentially Contaminated Soil. Part 2: Volatile Substances. Standards Australia, Canberra

EPA Victoria, publication IWRG701, June 2009, Sampling and analysis of waters, wastewaters, soils and wastes.



FEEDLOT DESIGN AND CONSTRUCTION

8. Bulk earthworks

AUTHORS: Rod Davis and Mairead Luttrell

Introduction

Bulk earthworks create pens, runoff and drainage control, drains, roads, silage pits, buildings, sedimentation structures and holding ponds. They also prepare for the foundations of buildings and structures that are to be erected including site offices, grain storages, feedmill, workshop and cattle handling facilities and the levelling of areas for the road network.

Earthworks carry a significant initial capital cost and it is therefore important to get this design right from the start; mistakes will be difficult and expensive to correct once work has commenced.

Pens, runoff control and effluent storage are the largest component of the earthworks. Bulk earthworks for these are usually undertaken using materials from within the site. If suitable materials are not available from within the site they can be brought in from off site, but at a higher cost. Bulk earthworks must be executed in conjunction with other processes including, but not limited to, surface and subsurface drainage works, underground services and environmental control measures.



Bulk earthworks start with dozers...



...and scrapers.

Design objectives

Pens, runoff control systems and effluent storage earthworks should be designed to

- drain downslope from the feed apron towards the runoff control and storage elements
- provide a comfortable pen surface for cattle while lying or standing
- provide a durable and stable pen surface that is resistant to rainfall erosion and cattle damage
- provide a stable pen surface for cleaning and other equipment
- provide a pen surface that does not degrade the value of manure by admixing
- facilitate low ongoing maintenance costs
- ensure that the engineering works perform in accordance with their design capacities or capabilities
- ensure that structures containing and controlling runoff maintain their integrity and compliance with specified design criteria
- prevent adverse impacts on groundwater and surface waters.

Mandatory requirements

Compliance with

- National Guidelines for Beef Cattle Feedlots in Australia (MLA, 2012a)
- National Beef Cattle Feedlot Environmental Code of Practice (MLA, 2012b)
- relevant Commonwealth, state and local authority codes, regulations and relevant Australian standards as applicable to the feedlot development.

The National Guidelines for Beef Cattle Feedlots (MLA, 2012a) state that

- If a groundwater assessment indicates a high potential for contamination of underground water resources because of leaching of nutrients through permeable, underlying rock strata, an impermeable barrier will be needed between the contaminant and the groundwater. This is required if the permeability of underlying soil/rock strata exceeds 0.1 mm/day.
- Clay liners should have a maximum permeability of 1×10^{-9} m/s (~ 0.1 mm/day) for distilled water with 1 m of pressure head.
- Catch and main drains, the sedimentation system and holding ponds should be underlain by at least 300 mm of clay or other suitable compacted soil or a synthetic liner able to provide a design permeability of $< 1 \times 10^{-9}$ m/s (~ 0.1 mm/day).

Design steps

Typically, bulk earthworks will include the following steps

- setout
- clearing vegetation
- removing topsoil
- removing and replacing any unsuitable material
- cuttings and embankment construction
- any spoil or borrow activities
- any additional processing of selected material for the selected material zone.

Staged construction

Operational requirements, funding limitations and other considerations may dictate that construction of expanded or new facilities is undertaken in a staged manner. Stages are tailored to match operational requirements and required market levels, with the basic philosophy being able to ensure that maximum use is made of existing infrastructure in subsequent development stages.

Therefore, it is important to consider the requirements for the earthworks of the full development at the start of the project if further stages are likely. A staged earthwork plan can reduce double handling and other inefficiencies. For example, it is usually more cost effective to prepare a larger surface area utilising cut and fill quantities. The location of initial borrow areas and stockpiles may also impact on future development areas. Similarly, the construction of effluent storage ponds should cater for the full development as these structures are difficult to extend.

Setting out of earthworks

The design information must be transferred from design to the field with precision and detail. This may occur by either

- the traditional approach – physically position and detail the extent of all cuttings and embankments shown on the drawings as well as transitions from cuttings to embankments using pegs and batter profiles or equivalent. Once the bulk material is removed, additional survey pegs are then required for the trimming of each pen. Additional features such as drains will also require survey pegging.



Step 1. Setting out earthworks



Effective erosion control measures should be installed to protect the working area and newly formed surfaces.



Step 2. Clearing vegetation

- GPS machine control – design information can be loaded into the construction machinery, enabling the operator to view real-time cut and fill values and horizontal and vertical data across the construction site. Traditional set-out pegs are no longer required.

The benefits of GPS-guided plant include independent operation and less survey pegging resulting in significant cost benefits, improved accuracy, easy design updates, the inclusion of unplanned works and increased safety.

Before starting earthworks, the levels of the existing natural surface should be verified by the construction contractor. This approach may prevent later disputes on earthwork quantities from a variation between design data and existing ground levels.

Protection of earthworks

Effective erosion and sedimentation control measures should be installed to protect the working area as well as the surrounding environment. Drainage should ensure run-off water does not scour the working area. Water should not be allowed to pond in the working area resulting in wetting up of the foundation material.

A sediment and erosion control plan (SECP) which outlines the sediment and erosion control measures for the works may need to be prepared.

Should earthworks material become over-wet (above the specified moisture content for compaction), the material will need to be left to dry out. Earthworks material should not be allowed to dry out to the point where excessive shrinkage occurs and the surface is pulverised by traffic generating excessive dust. Dust control is critical not only from an environmental impact perspective but from an animal welfare perspective during expansion or redevelopment construction works.

Clearing and grubbing

Clearing is carried out in advance of any earthwork operations both from within the boundaries of areas affected by earthworks or other areas to be cleared as designated on the approved design drawings. Clearing consists of cutting, taking down, removing and disposing of everything above ground level, except where such trees, vegetation, structures or specific sites are designated to remain. The material to be cleared shall include, but not be limited to, trees, stumps (parts above ground), logs, bushes, undergrowth, long grasses, crops, vegetation, large rocks, abandoned services and structures.

Grubbing consists of the removal and disposal of surface vegetation, the bases of stumps, roots, the underground parts of structures and other obstructions to the depth specified in the earthworks specifications. Typically these are removed to a depth of not less than 300 mm below the subgrade level in areas where future earthworks will be required. Grubbed holes should be backfilled and well compacted with the foundation material.

Removal of topsoil

Topsoil is surface soil which is normally high in organic material and contaminated by residual grass seed and grass roots and reasonably free from subsoil, refuse, clay lumps and large stones.

In most cases, topsoil is unsuitable for use as foundation material for bulk earthworks due to the high organic matter and contamination by other materials e.g. rocks and timber.

Topsoil can only be removed once clearing and grubbing and disposal of materials has been completed and sediment and erosion control measures have been implemented on that section of the works.

Topsoil should be stockpiled separately clear of the work area with care taken to avoid contamination by other materials. The topsoil stockpile should also be accessible for later use for covering finished embankments and re-establishment of site vegetation once works have been completed.

The depth of topsoil to be removed will be indicated on the engineering plans. Typically the depth of topsoil removed is not less than 150 mm. However, the actual depth is usually assessed on site during excavation.

Topsoil stockpile sites

Topsoil should be stockpiled in dedicated stockpile sites. These sites are usually nominated on the approved design drawings. Stockpile sites are located to minimise damage to natural vegetation, and maintain the existing surface drainage such that material from the stockpiles does not enter drainage lines or watercourses. They are located so that the stockpiled material is accessible for carting away at any time.

Typically, the maximum height of stockpiles is about 2.5 m and a maximum batter slope of 2H to 1V. Slope and batter is expressed in rise over run— for every 1 metre of rise (vertical) there is a 2 metre of run (horizontal). To minimise erosion, stockpile batters are usually track rolled or stabilised by other acceptable means.

Temporary erosion and sedimentation control measures to protect the stockpiles should be installed and maintained.

Cuttings

All excavation needs to be carried out to the required lengths, breadths, depths, inclinations and curvatures as required for the construction of the permanent works, in whatever material that may be found.

Groundwater may be encountered when material is removed during cuts. This will be most likely from underground streams and springs in areas with cohesionless (sandy or gravelly) soil or water-yielding rock. In this case, the area may need dewatering with mechanical equipment (i.e. pumps) or subsoil drainage may need to be installed using suitable slotted-pipe drainage pipe.



Step 3. Removing topsoil



Problems may arise during construction earthworks. Groundwater encountered will need appropriate drainage.

Unsuitable material

The suitability of material for construction is assessed on the basis of its geotechnical qualities. Soil testing during site investigations determines the nature of the material on the proposed feedlot site. The results of these tests will identify whether material is suitable for construction. Refer to *Section 7 – Site investigations* for more detail on soils investigation.

Even though soil investigations may indicate that materials are suitable for construction, unsuitable materials may still be encountered below the design level of cuttings and below the nominated depth for stripping topsoil beneath embankments.

Unsuitable material may include

- cohesive soils having a liquid limit in excess of 90% or plasticity index in excess of 65%; any material containing topsoil, wood, peat or waterlogged substances
- any material containing biodegradable or organic material (more than 5%); any material containing scrap metal
- material from contaminated sites
- material which by virtue of its particle size or shape cannot be properly and effectively compacted e.g. sand
- large rocks.

The construction contractor and lot feeder may need to locate a borrow pit to obtain suitable construction material. If large enough, this borrow pit may be used in the future as a source of material for pen maintenance. Alternatively, the borrow pit could be the location of future runoff storage structures.

Materials that are soft or unusable merely because they are too wet or too dry for effective compaction are not usually classified as unsuitable, unless otherwise defined by the earthworks specifications.

Unsuitable material should be excavated and disposed of as directed to spoil or as fill in areas in which it would be deemed suitable. The unsuitable material which has been removed must be replaced with suitable material from cuttings, or with material borrowed from elsewhere on or off the site.

Suitable material

Typically, the construction contractor will be required to have visited and examined the site to ascertain its general nature and the kinds of materials to be excavated prior to the submission of the tender.

Soils may need to be mixed or engineered to produce a material that meets the foundation, sub-base or lining specifications. The parameters of interest include permeability (for protecting groundwater) and strength (for trafficability). The performance criteria required to be met for the material used for pen and road surfaces, and manure stockpiling/composting areas can be found in *Section 17* and the material performance criteria for clay liners for holding ponds is found in *Section 12*.

If significant earthworks are required to create suitable slopes, a borrow pit will be needed to source suitable additional material for pen and road surface construction. The location of this borrow pit should be determined during the site investigation stage where



Unsuitable material such as large rocks should be excluded from earthworks.

material samples from several locations are tested for suitability. From an economic viewpoint, the borrow pit should be sited as short a haul distance as possible from the construction area to avoid expensive long material hauls. Borrow sites should have cut batter slopes not steeper than 4H to 1V.

Permeability

The National Guidelines for Beef Cattle (MLA, 2012a) provide guidance on the selection of the materials suitable for use as clay lining and pen surfacing. State guidelines may also outline material specifications.

Table 1. Specifications for clay liner materials

Soil characteristic	Acceptability criterion	Test method
Percentage fines	More than 25% passing a 75 µm sieve	AS 1289 3.6
	More than 15% passing a 2 µm sieve	
Liquid Limit	Less than 70	AS 1289 3.1.1
Plasticity Index	More than 15	AS 1289 3.3.1
Emerson Class Number	5 to 6	AS 1289 3.8.1

More detail on the material specifications for clay liners in holding ponds can be found in *Section 12*.

The finished surface of the clay liner or pen should be trafficable for cattle and equipment. The minimum depth recommended for the clay liner is 300 mm after compaction.

The design pen surface levels may include an allowance for a sacrificial or wearing layer to ensure that the integrity of the liner is maintained. The depth of the wearing layer and liner should be sufficient to ensure that equipment does not damage the liner during harvesting of manure, although periodic repair of the pen surface will be necessary due to the wear and tear associated with cattle traffic and normal cleaning operations. A supply of suitable material should be identified on site.

Strength

To measure the soil's ability to handle a load, the mechanical strength of the material is typically determined by the California Bearing Ratio (CBR). The CBR test is used in the design and analysis of both rigid and flexible road pavements.

CBR is a strength test that compares the bearing capacity of a material with that of a well-graded crushed stone (thus, a high quality crushed stone material should have a CBR ~ 100%). It is primarily intended for, but not limited to, evaluating the strength of cohesive materials having maximum particle sizes less than 19 mm.

Though CBR is apparently a ratio of forces, in reality it is a stiffness ratio, since it gives the ratio of forces required for a given penetration. Table 2 shows the typical range of CBR values for various unified soil classification types. (See also Table 1 in *Section 17*).

Bulking and shrinkage (cut to fill ratio)

Bulking occurs when soil is excavated. One cubic metre of in situ material expands and does not always translate into one cubic metre of fill when placed and compacted on the site. Bulking can have a significant effect on the balance of cut and fill volumes and hence the cost of the earthworks. To allow for this, the earthworks



Field testing soil strength

specifications must state the measure of volume for the material. For example, a ‘bank cubic metre’ represents the volume of soil in the ground before it was excavated and an ‘excavated cubic metre’ represents the volume of soil after it is excavated.

Table 2. Typical range of CBR values (Fahey 2009)

General soil type	USCS Soil Type*	CBR Range %
Coarse-grained soils (>75 µm)	GW	40 – 80
	GP	30 – 60
	GM	20 – 60
	GC	20 – 40
	SW	20 – 40
	SP	10 – 40
	SM	10 – 40
	SC	5 – 20
Fine-grained soils (<75 µm)	ML	15 or less
	CL L <50%	15 or less
	OL	5 or less
	MH	10 or less
	CH L >50%	15 or less
	OH	5 or less



Soil fill in earthworks must be compacted. This sheepfoot compactor combines high speed and capacity compaction control.

*USCS soil types are detailed in Section 7 – Site Investigations. The National Guidelines for Beef Cattle (MLA, 2012a) state a minimum standard for CBR wet and dry of 20% for pen surfaces.

When the material is compacted, its volume decreases. This is referred to as shrinkage.

Disputes over bulking factors (cut to fill ratio) and shrinkage are common between construction contractors and the project manager or lot feeder.

Filling (embankment)

Filling must be carried out to the lines, levels and grades required to complete the design surface. Filling or embankment construction includes

- all operations associated with the preparation of the foundation areas on which fill material is to be placed
- the placing and compacting of approved material within areas from which unsuitable material has been removed
- the placing and compacting of fill material and of materials of specified quality in nominated zones throughout the works
- all other activities required to produce embankments as specified to the alignment, grading and dimensions shown on the drawings.
- any pre-treatment such as breaking down or blending material, wetting or drying out material containing excess moisture.

Typically, material for filling is obtained from the excavations within the site (Figure 1), supplemented by borrow material if necessary. The material must be free of tree stumps and roots and be capable of being compacted in accordance with the earthworks specification. (See Section 12 for more detail on material specification for clay liners in holding ponds.)

In general, fill materials will be well-graded suitable material as stated in the earthworks specifications.

Foundations will need to be prepared on which fill will be placed. Typically, foundations are prepared after removing topsoil and unsuitable material, by loosening the exposed material to a depth of not less than 200 mm, adjusting the moisture content of the loosened material and compacting to the levels specified in the earthworks specifications.

It is critical that the methods of excavation, transport, depositing and spreading of the fill material are selected to ensure that the placed material is uniformly mixed.

In embankments other than pond embankments, rock material may be broken down and evenly distributed through the fill material, and sufficient fine material placed around the larger material as it is deposited to fill the voids and produce a dense, compact embankment.

Fill materials are generally placed in layers and uniformly compacted to the design (dry density at optimum moisture content) specification before the next layer is applied. The loose thickness of each layer should not be greater than 300–400 mm depending on the type of compaction machinery.

Each layer of fill must be processed as necessary to bring its moisture content to a uniform level throughout the material suitable for compaction. The optimum moisture content as determined by the laboratory compaction test is used as a guide in determining the proper moisture content at which each soil type needs to be compacted. Compaction should not be carried out when the fill is too dry or too wet as the degree of compaction will be unsatisfactory. In the case of dry fill, the moisture content needs to be increased by spraying with water using water trucks (or similar) as the compaction proceeds. In wet fill, material shall be aerated and dried to adjust the moisture content to obtain the required density.

The National Guidelines for Beef Cattle Feedlots state that clay lining material should be placed in layers of 150mm (± 50 mm). Each layer should be tined, wetted to $\pm 2\%$ of optimum moisture content and compacted to the required compaction (relative to the Maximum Dry Density) that is needed to achieve the required permeability of 1 mm/day. The minimum depth recommended for the clay liner is 300 mm after compaction.

The contractor should be required to carry out compliance field tests to check the degree of compaction attained on site is in accordance with the earthworks specifications.

Slope (or batter) stability

Some natural slopes exist in a state of marginal stability and relatively minor works such as trenching, excavation, removal of scrub and vegetation, or the erection of buildings, can lead to failure. Signs of instability include

- cracked surfaces
- crescent-shaped depressions
- crooked fences
- trees or power poles leaning uphill or downhill



Dry surfaces may need spraying with water to allow the required degree of compaction.



Optimum moisture level of soil permits a strong cast formed from sheep's foot roller compaction.



Field testing soil compaction



Acceptable limits for cut and fill slopes depend on soil type and strength, geology of the site and saturation.

This unsaturated embankment has drainage pipes that direct water from trough overflow and pen cleaning away from the embankment to the runoff control system

- uneven surfaces, or wet ground in elevated positions
- plants such as rushes growing on a slope
- water seeping from the ground.

In most cases, it is unnecessary or impracticable to measure quantitatively the factor of safety of a slope against shear failure. Maximum slopes of cuts and fills may be determined by the geotechnical engineer from experience and from observation of slopes in the vicinity which have a long-standing history of stability, are of similar height to the proposed slope and are of apparently similar geological formation.

Where necessary or where a precedent is not available, a special soils engineering investigation should be carried out by the geotechnical engineer to determine acceptable limits to cut and fill slopes. In assessing slope stability, account should be taken of possible future changes in ground water level or other conditions. Groundwater is the major cause of slope failures.

Slopes of embankments must be stable under all conditions of construction and operation. Figures 1 to 4 illustrate typical embankment types that may be found at a feedlot. These include above-ground water and effluent storages such as turkey's nest, ring tanks and holding pond (Figure 3), above-ground road and pen embankments (Figures 1 and 2) and structures with no embankment height (i.e. below ground water and/or effluent storages) (Figure 4).

Figure 1 shows a typical balanced cut and fill earthworks. This approach is used on relatively flat sites to minimise the volume of earthworks.

Often embankment slopes are chosen on more practical issues such as the ability to place and retain a topsoil cover or the ability to undertake bank maintenance.

Figure 1. Balanced cut and fill

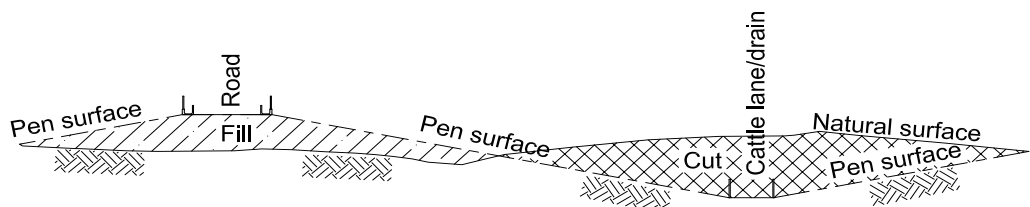

Figure 2 illustrates a bench cut. This approach is used on sites where sufficient natural fall is available for the pen slope and a cutting is required to obtain the required grade for the feed road.

Figure 2. Bench cut

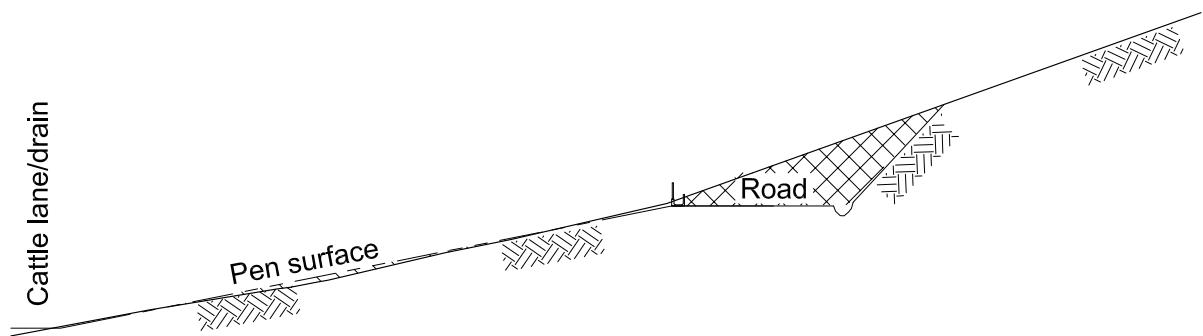

Figure 3. Above-ground earthen storage

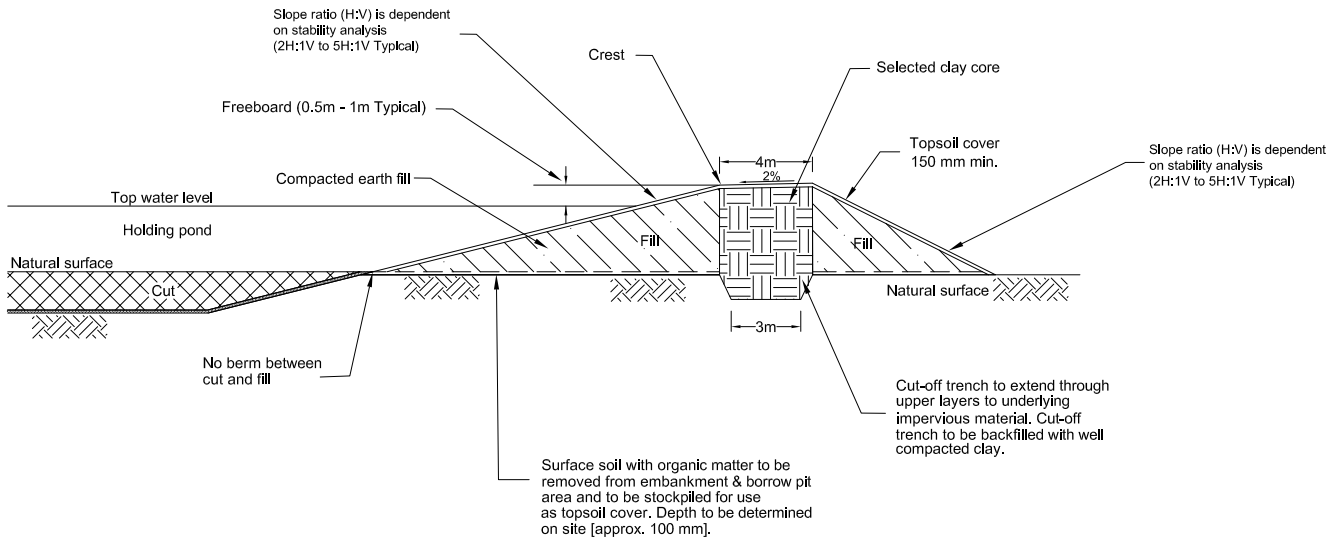
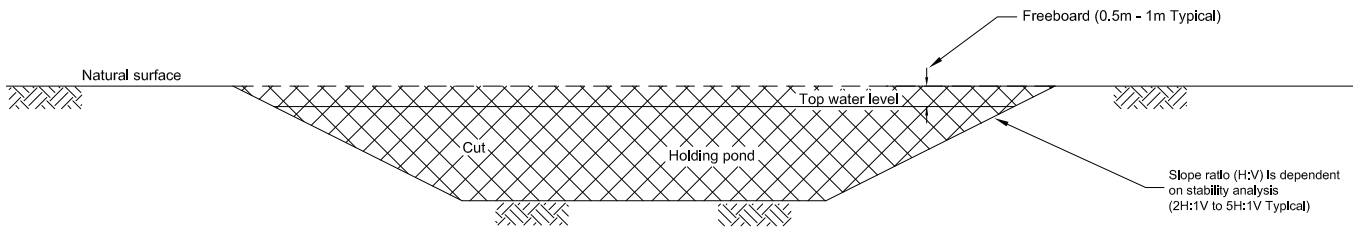

Figure 4. Below-ground storage



The stability of an embankment is determined by its ability to reduce shear stresses, which can cause failure by inducing sliding along a shear surface. Shear stresses result from externally applied loads (such as water or traffic) and internal forces caused by the weight of the soil and embankment slopes.

The design slope chosen will depend on the following parameters

- soil types and strength parameters
- soil layering – changes in geology of the site e.g. soft layers
- saturation – variation in groundwater levels, perched water, potential for rapid drawdown and effects of irrigation
- external loads – e.g. long-term (buildings) versus short loading (e.g. roads)
- construction – the construction technique, schedule and any safety issues
- erosion control – particularly where sand, non-plastic silt and dispersive clays are used as embankment fill materials or found in cut slopes
- maintenance considerations.

The most critical post-construction condition for the stability of an embankment slope is the saturation condition and the drawdown rate after a period of saturation.

For example, embankment slopes on downstream sides of structures adjacent to areas subject to flooding may require a flatter slope than would otherwise be needed if a rapid lowering of the water level (drawdown) could occur (i.e. rise and fall of floodwaters). This is to prevent rapid drawdown failure.



Smoothing embankments with a grader



Batters that are too steep for the soil type and strength will collapse.

Slope stability analysis should be carried out by a qualified and experienced designer (usually a geotechnical engineer).

Spoil

Spoil is surplus material from excavations which is not required to complete the earthworks as specified or material from excavations whose quality is deemed to be unacceptable for incorporation into the earthworks.

Consideration should be given as to where this material can be utilised, stockpiled or disposed of on site. For example, surplus material may be used to flatten batter slopes on embankments which have not been commenced, and/or directed to uniformly widen embankments.

Trimming and finishing of surfaces

Unless otherwise specified, all areas within the limits of clearing and outside the limits of earthworks should be graded to an even surface. Ridges should be trimmed and depressions filled as necessary to produce a surface which will drain freely and is suitable for the operation of maintenance equipment.

Tolerances

Tolerances are specified to allow reasonable leeway for imperfections and inherent variability in the earthworks without compromising performance.

Tolerances may be specified on completion of cutting, filling and all incidental operations and before the placement of covering materials. Tolerances will be specified on finished surfaces.

Tolerances in level and shape will be itemised in the earthworks specifications.

Quality assurance

Quality assurance is an important aspect of earthworks. Earthworks certification and compliance may be required prior to, and during, earthworks. Site inspections and testing activities (e.g. compaction and CBR) are usually carried out as part of the certification and compliance process.

Site inspections and testing activities are usually conducted by accredited third parties in accordance with Australian Standard 3798: Guidelines on earthworks for commercial and residential developments.

Site inspections and testing activities ensure that the earthworks specifications (and any Development Permit requirements) are complied with. This includes

- verifying the setout and site constraints
- ensuring foundations have been suitably prepared. For example, vegetation has been cleared, topsoil has been stripped and the area cleared of organic and foreign material if required
- that unsuitable materials are not used as fill



Graders are used for excavation, batters and precision finishing in the final shaping of surfaces (e.g. roads, pens, building foundations).

- that the methods of excavation, transport, depositing and spreading of the suitable material ensure that the material is uniformly mixed and placed according to specifications
- that all fill layers are uniformly compacted to not less than the relative compaction specified before the next layer is commenced
- that surface and percolating water will not undermine the stability of the excavation and nearby ground through the process of ground loss, consolidation and/or increase in lateral earth loading
- that requirements under Development Application permits are in place. For example, sediment and erosion control plans, stormwater management plans, pond lining testing and rehabilitation plans
- that non-compliant earthworks are rectified
- minimising disputes over earthwork activities and quantities
- verifying where payment can be made for activities associated with completing all or sections of the earthworks.

Building foundations

Typically, the bulk earthworks for building structures (e.g. offices, commodity/machinery/cattle handling facilities, silos, feed preparation and shade structures) and pens and drainage areas are similar. However, building structures may need additional ground improvements to obtain a suitable foundation.

The type of foundation depends on the type of rock or soil and how that type is influenced by changes in moisture, temperature and imposed loads from the structure above. Foundations are usually classified as either reactive or non-reactive to changes in their moisture content.

Reactive soils are typically clay soils but also include the 'black soil' and 'black earth' found in Queensland, South Australia and Western New South Wales. All of these are plastic soils that shrink and swell rapidly as their moisture content decreases or increases. For these soils, linear shrinkage is used to correlate soil volume change.

Non-reactive soils are soils such as rock, gravel, shale, phyllite or sand, where their volume does not increase or decrease with changes in the moisture content.

A geotechnical survey to determine the soil profile of a building area should be conducted in accordance with the Australian Standards AS2870-1996: Residential Slabs and Footings - Construction and AS1726-1993: Geotechnical site investigations. (See *Section 7 – Site investigations*).

The design of building structures needs an appreciation of many factors including foundation design and therefore must be carried out by a suitably qualified and experienced designer (usually a structural engineer).



Smooth-drum rollers are used to compact the high spots until the surface is smooth—usually after a grader has levelled the surface.



Suitability of material for construction should be assessed on its geotechnical qualities.



Erosion and sediment controls should be implemented downstream of working areas to prevent off-site impacts.

Erosion and sediment control measures

Earthworks activities may increase the risk of the disturbed soils being eroded – mostly by water. The loss of soil can result in the earthworks failing with consequent repair costs, or impacts upon the receiving environment.

Erosion and sediment control measures should be implemented to effectively manage erosion and sediment control issues. An approved Erosion and Sediment Control Strategy or Plan may be a mandatory requirement for the earthworks under state legislation or local authorities planning schemes.

Typically, erosion and sedimentation control measures include

- installing diversion and drainage structures before removing topsoil and starting the earthworks
- stabilising diversion and catch drains to prevent uncontaminated runoff from outside the disturbed areas entering the site
- providing contour and diversion drains across exposed areas before, during and immediately after clearing and re-establishing and maintaining these drains during soil removal and earthworks operations
- providing sediment filtering or sediment traps, in advance of and in conjunction with earthworks operations, to prevent contaminated water leaving the site
- limiting areas of erodible material exposed at any time to those areas being actively worked
- minimising sediment loss during construction of embankments by means such as constructing berms (raised barrier separating two areas) along the edge of the formation leading to temporary batter flumes and short-term sediment traps
- progressive vegetation of the site as work proceeds
- adequate protection of stockpile sites from erosion and contamination of the surrounding area.

Quick tips

- Mark up site plans to show major site and building staging requirements (e.g. topsoil piles, fill piles, parking areas, material storage areas, layout locations). These may highlight practical difficulties and contractual problems that could occur.
- Ensure the construction contractor verifies levels of the existing natural surface. This may prevent disputes on earthwork quantities from a variation between design and existing natural surface levels.
- Dispose of unsuitable or excess excavation material in locations that will not cause water quality or other environmental impacts.
- Ensure setout pegs and benchmarks are placed so that they are not disturbed during earthworks.
- Use balanced cut and fill construction where practical to minimise earthworks.
- Confirm suitability of material with geotechnical testing of material.
- Disputes over bulking factors are common, and specialist advice should be obtained.
- Specialist advice should be obtained for maximum slopes of cuts and fills.
- Flatter cut slopes are required in coarse granular and unconsolidated soils, in wet areas and in soft or clay-rich soils.
- Consider dust, erosion and sediment control measures to minimise impacts on the receiving environment.
- Engage the services of a suitably qualified and experienced person for the design of building structures.

Further reading

Standards Australia, AS2870-1996: “Residential Slabs and Footings - Construction” and AS1726-1993: “Geotechnical site investigations”.

Standards Australia, AS3798-1996, AS3798 – Guidelines on Earthworks for commercial and residential buildings.

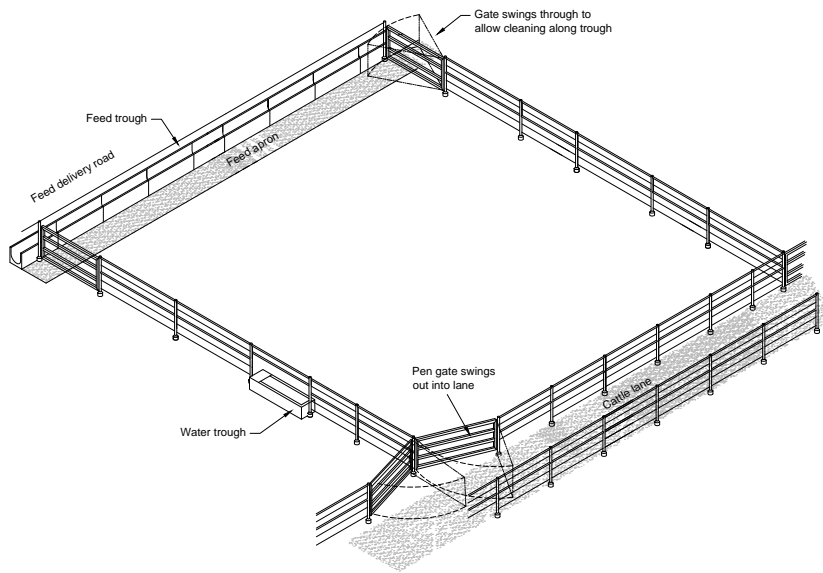

3D Feed Pen Layout



FEEDLOT DESIGN AND CONSTRUCTION

9. Overall pen layout

AUTHORS: Peter Watts and Rod Davis

Introduction

The production pens are the main animal housing unit for a cattle feedlot. Sound design will ensure optimum animal performance, good animal welfare and high standards of environmental performance.

Design objectives

The design objectives for a feedlot production pen are to

- provide an environment for cattle where production performance and animal welfare are maximised
- promote safe access for cattle to and from the pen
- minimise environmental impacts such as odour and dust
- promote drainage to provide a comfortable environment for cattle and minimise environmental impact
- optimise the management and removal of manure from the pens
- minimise ongoing maintenance costs
- provide a safe working environment for pen riders and other feedlot personnel.



Pen design choices



Mandatory requirements

Apart from pen slope and pen floor permeability, the National Guidelines do not provide any specific design requirements for production pens. Pen slope is addressed in *Section 10 – Pens and drainage systems*, and pen floor permeability is discussed in *Section 8 – Bulk earthworks*.

The National Feedlot Code of Practice recommends a maximum stocking area of 25 m² per Standard Cattle Unit (SCU). In circumstances where a feedlot operates at a lower stocking area (>25 m² per SCU) the feedlot manager is responsible for justifying the greater density and for obtaining approval from the appropriate authority. Stocking areas lower than 20 m² per SCU can encourage increased pen dust loads and require higher capacity for sedimentation and holding ponds.

The Australian Animal Welfare Standards and Guidelines for Cattle (DAFF, 2013) state

S10.1 A person in charge must ensure a minimum area of 9 m² per Standard Cattle Unit for cattle held in external pens.

G10.10 Feed yard facilities should comply with the requirements of the National Beef Cattle Feedlot Environmental Code of Practice, 2nd Edition, as amended or superseded.

Design choices

Once a particular feedlot layout has been chosen, the next step is pen design (see Figure 1). Factors requiring consideration include

- stocking density
- bunk space per head
- pen slope
- pen head capacity
- access to the pen
- provision for shade, if required.

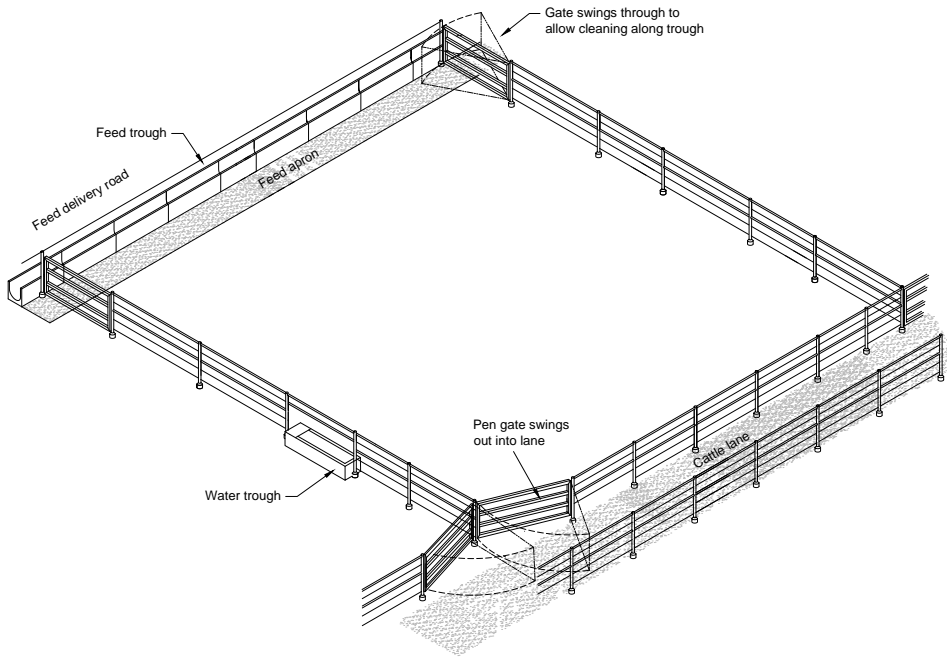

Figure 1. Production pen design parameters

The dimensions of a feed pen depend on the capacity of the pen, stocking density and the amount of feed bunk required. Figure 2 shows how stocking density (SD), feed bunk length (FBL) and pen capacity relate to the dimensions of a typical feedlot pen.

Pen dimensions

Pen dimensions are determined by the combination of stocking density, bunk length per head and pen capacity as per the figure below.

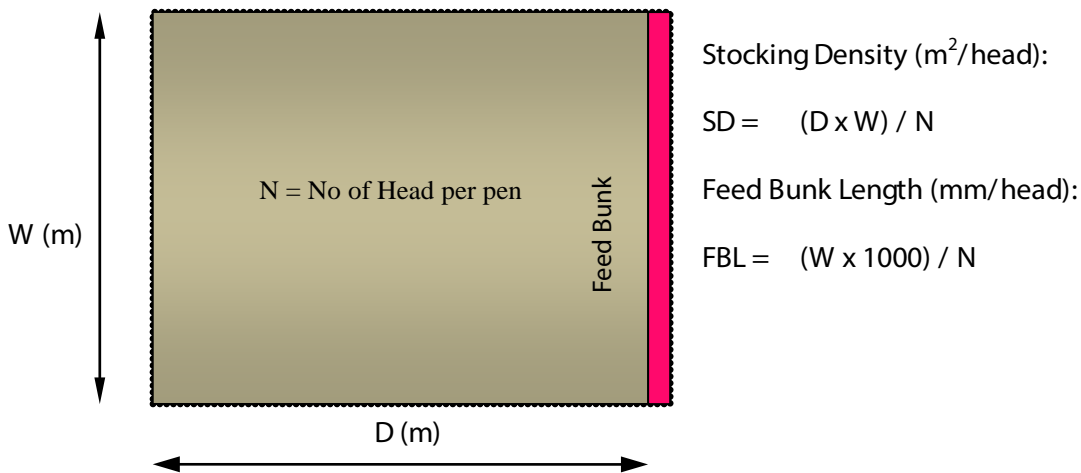

Figure 2. Pen dimensions

The following tables show the different dimensions for 100, 150 and 200 SCU pens as affected by stocking density and bunk space per head. Pens with smaller capacities can be narrow, presenting problems for the use of pen cleaning machinery.

Table 1. Pen dimensions for a 100 SCU pen

Stocking density (m ²)	10		15		20	
Bunk space (mm/head)	250	300	250	300	250	300
Width, W (m)	25.0	30.0	25.0	30.0	25.0	30.0
Depth, D (m)	40.0	33.3	60.0	50.0	80.0	66.7

Table 2. Pen dimensions for a 150 SCU pen

Stocking density (m ²)	10		15		20	
Bunk space (mm/head)	250	300	250	300	250	300
Width, W (m)	37.5	45.0	37.5	45.0	37.5	45.0
Depth, D (m)	40.0	33.3	60.0	50.0	80.0	66.7

Table 3. Pen dimensions for a 200 SCU pen

Stocking density (m ²)	10		15		20	
Bunk space (mm/head)	250	300	250	300	250	300
Width, W (m)	50.0	60.0	50.0	60.0	50.0	60.0
Depth, D (m)	40.0	33.3	60.0	50.0	80.0	66.7



Wet winters are an issue for stocking density, particularly with winter-dominant rainfall.



Low stocking densities under low rainfall conditions can lead to dust, especially in the late afternoon.

Stocking density

Stocking density has a significant influence on the environmental performance of a feedlot since it partly determines the average moisture content of the pad. Every day, cattle add moisture to the pen surface by manure (faeces and urine) deposition.

Figure 3 shows the estimated moisture added to the pen surface each year for cattle of various weights kept at different stocking densities.

This simple calculation assumes that cattle excrete 5% of their liveweight each day and manure is 90% moisture. Heavy cattle (750 kg) at 10 m²/head can add over 1200 mm of moisture per year (3.3 mm/day). During winter, if this exceeds the evaporation rate (depending on location) the pad remains moist, and odour and cattle comfort problems can develop. On the other hand, light cattle kept at 20 m²/head contribute less than 1 mm of moisture/day. In summer, evaporation readily removes this moisture and dust can become a problem.

The choice of stocking density to achieve a balance between a pen surface that is too dry and one that is too wet depends on local climate and cattle size.

Following the USA example, feedlots in Australia initially stocked pens at about 10 m²/head but experience has shown that this stocking density is appropriate only in drier zones (annual rainfall <500 mm/yr). For most feedlots in the grain belt, a stocking density of about 15 m²/head achieves an optimum outcome for cattle, pen environment and pen maintenance.

The effect of added moisture is a particular issue for covered feedlots where, for economic reasons, stocking densities are high (around 2.5–6 m²/head). See Section 44 – Covered housing systems.

Even though rainfall is excluded, the added moisture can exceed 2000 mm/year and pen surfaces quickly become wet. Under these circumstances, a bedding material must be used to absorb the moisture and this bedding should be removed every few weeks.

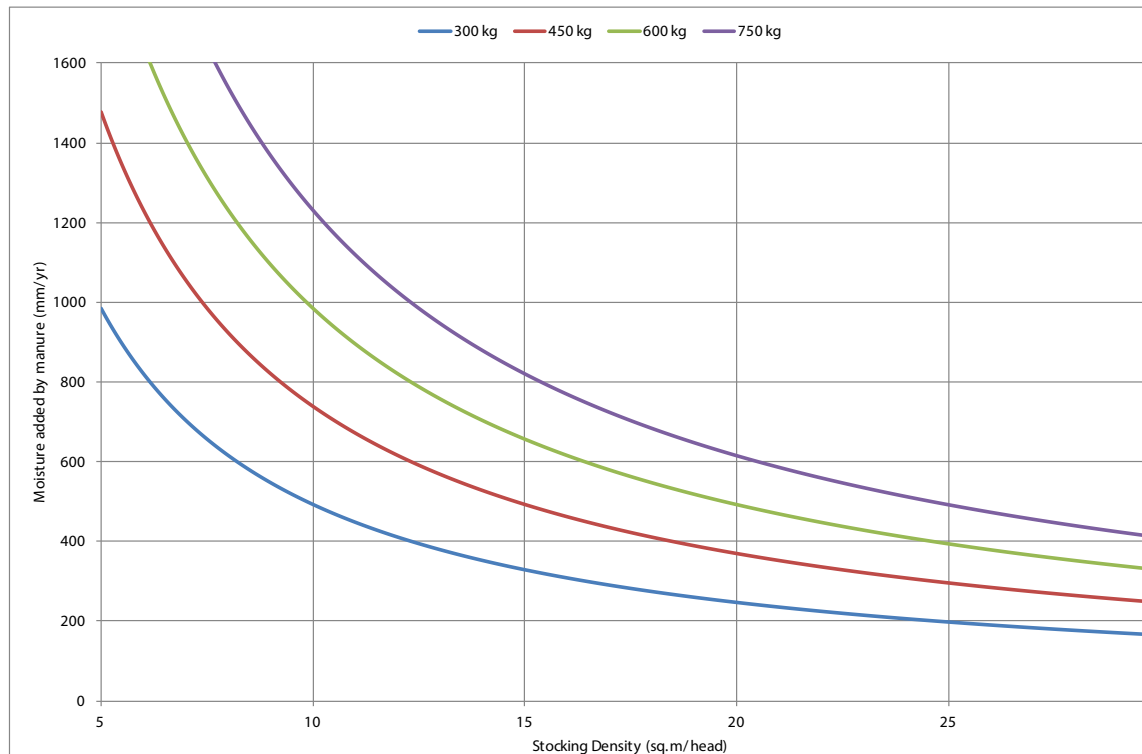

Figure 3. Effect of stocking density and cattle liveweight on moisture added to pen surface

Feed bunk space (per head)

The length of bunk space required per head is discussed in *Section 19 – Feeding systems*. Typically, this is in the range of 200 mm/head to over 300 mm/head.

Pen capacity (no. of head)

It is convenient to size pens to match multiples of deck sizes of livestock transport vehicles. A double deck semi-trailer would carry about twenty-six 450 kg cattle per deck giving a total load of 52 head. (Refer to the Land Transport Standards and Guidelines for loading densities of cattle on livestock transport vehicles. DAFF, 2013). A B-double load would be approximately seventy-eight 450 kg cattle.

Many commercial feedlots have a range of pen sizes from 50 head to 300 head. In custom feeding operations, a variety of pen sizes allows management to cater optimally for different sized customer consignments. When large consignments of cattle are fed, poor performers may be drafted off during the feeding period and may end up in 50 and 100 head pens before a quick sale. Many managers prefer to hold cattle in 80–100 head group sizes prior to trucking and/or container (carcase beef) lots depending on the combined weights of each consignment. The smaller pens are generally located closer to the cattle receipt and dispatch facilities.

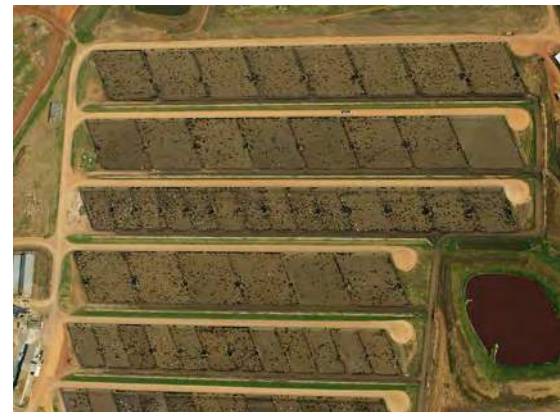

A range of pen sizes allows management to cater for different sized consignments.



Trees left in pens invariably die, and are difficult to clean around.



All pens should have signs noting the pen number. This sign configuration allows pen number to be read by both feed truck operators in the feed alley and pen riders in the back of the pen.

Pen slope

Section 10 - Pens and drainage systems discusses the selection of appropriate pen slope.

Pen orientation

If shade is to be installed at the feedlot, pen orientation can be important. Rows of pens running north-south generally make the design of shade structures easier. This is discussed in *Section 16 - Shade*.

Water trough location

The many options for locating water troughs in pens are discussed in *Section 20 - Water trough design and sewer systems*.

Each pen should preferably have access to two water troughs so that cattle can have access to water if one trough blocks. Water troughs can be placed in a subdivision fence line or in the rear centre of the pen.

Obstructions in pens

Obstructions within pens should be as few as possible as they interfere with cattle movement, pen cleaning machinery and good pen drainage. Trees should not be left in pens as they invariably die and are difficult to clean around.

Signage

All pens should have a small sign with the pen number. This sign should be at the top end of the pen along the feed bunk so that feed truck operators can locate the correct pen when delivering feed. It is also useful to be able to identify the pen number from the cattle lane with another sign on the entrance gate from the stock lane to the pen.

Further reading

National Guidelines for Beef Cattle Feedlots in Australia - 3rd Edition, Feedlot Industry Accreditation Committee (ed.), June 2012, Meat & Livestock Australia, Sydney, NSW.

DAFF, 2013, Australian Animal Welfare Standards and Guidelines for the Land Transport of Livestock, Department of Agriculture, Forestry and Fisheries, Australian Government, Canberra, ACT.

DAFF, 2013, Australian Animal Standards and Guidelines for Cattle, Department of Agriculture, Forestry and Fisheries, Australian Government, Canberra, ACT.

Guidelines for the establishment and operation of cattle feedlots in South Australia, Department of Primary Industries and Resources (SA) and Environment Protection Authority, 2006, Adelaide.

Victorian code for cattle feedlots, August 1995, Victorian Feedlot Committee, Department of Agriculture, Energy & Minerals, Melbourne.

Skerman, A 2000, Reference manual for the establishment and operation of beef cattle feedlots in Queensland, Information Series QI99070, Queensland Cattle Feedlot Advisory Committee (FLAC), Department of Primary Industries, Toowoomba, QLD.

Guidelines for the Environmental Management of Beef Cattle Feedlots in Western Australia, Bulletin 4550, 2002, WADo Agriculture (ed.), Western Australia Department of Agriculture, Perth, WA.

The New South Wales feedlot manual, 1997, NSW Agriculture, NSW Agriculture, Department of Land and Water Conservation, Department of Urban Affairs and Planning & Environment Protection Authority, Orange.



FEEDLOT DESIGN AND CONSTRUCTION

10. Pen and drainage systems

AUTHORS: Peter Watts, Rod Davis and Orla Keane

Introduction

Stormwater runoff from feedlots contains contaminants that, if allowed to enter natural watercourses, would constitute an environmental hazard. Feedlots must have a system that controls runoff from contaminated areas and provides for environmentally acceptable utilisation of the valuable water and nutrient resources of that runoff.

Design objectives

Feedlot pens and drains should be designed, constructed and maintained to ensure that

- All free rainwater drains quickly so that pens can dry quickly
- The pen surface does not erode during runoff
- Pens do not carry manure into other pens
- Odour emissions are minimised by quick pen surface drying
- Manure movement in pens is minimal
- Flow constrictions that could cause manure to deposit e.g. pipes/culverts/bends are designed to ensure that entrapped manure remains in the water flow
- There is minimal settling of manure in drains
- Drains are not subjected to excessive erosion or scouring
- Drains have sufficient capacity to convey design flow rates without overtopping
- Drains surfaces are impermeable to prevent effluent infiltration into groundwater
- Drains can be cleaned easily.

Mandatory requirements

The National Guidelines for Beef Cattle Feedlots in Australia state that a controlled drainage system should be designed so that

- Drains can safely carry the peak flow rates resulting from a design storm event with an average recurrence interval (ARI) of 20 years.
- The duration of the design storm event should be taken as being equal to the time taken for water to flow from the most remote point of the catchment area to the catchment outlet (time of concentration).
- Flow velocities in drains during the 20-year ARI design storm event should be greater than 0.5 m/s but at the same time be non-scouring.
- Catchment and primary drains should be underlain by a thickness of at least 300 mm of clay or other suitable compacted soil, or a synthetic liner able to provide a design permeability of $<1 \times 10^{-9}$ m/s (~ 0.1 mm/d).
- Manure stockpiling and/or composting areas should be underlain by a thickness of at least 300 mm of clay or other suitable compacted soil, or a synthetic liner, to provide a design permeability of $<1 \times 10^{-9}$ m/s (~ 0.1 mm/d).

Pen drainage design

A controlled drainage area for a feedlot must include a drainage system for conveying stormwater runoff from pens to holding ponds.

A controlled drainage area (see Figure 1) is typically established using

- A series of catch drains to capture rainfall runoff from the feedlot pens and all other surfaces within the feedlot complex, and convey that contaminated runoff to a collection and utilisation system.
- A series of diversion banks or drains placed immediately upslope of the feedlot complex to divert any 'clean' or uncontaminated upslope runoff (sometimes termed 'run-on') around the feedlot complex away from the controlled drainage area.

Where feedlots are built close to the crest of a hill or ridge and there is no side slope, and hence no 'run-on', a controlled drainage area might not need any upslope diversion banks. However, in practical terms it is unlikely that no diversion banks and drains will be required.

Depending on the topography and layout of the site, a feedlot may have more than one controlled drainage area. The controlled drainage system should include the following elements

- production pens
- livestock handling facilities including livestock loading and unloading facilities
- hospital and recovery pens
- solid waste storage and processing facility
- feed commodity storage and processing facilities
- cattle and truck washdown facilities
- cattle lanes
- feed lanes or alleys
- silage pits
- runoff catch drains
- run-on diversion banks
- sedimentation system
- holding pond(s).



Aerial photo of a feedlot catchment area draining down to a holding pond.

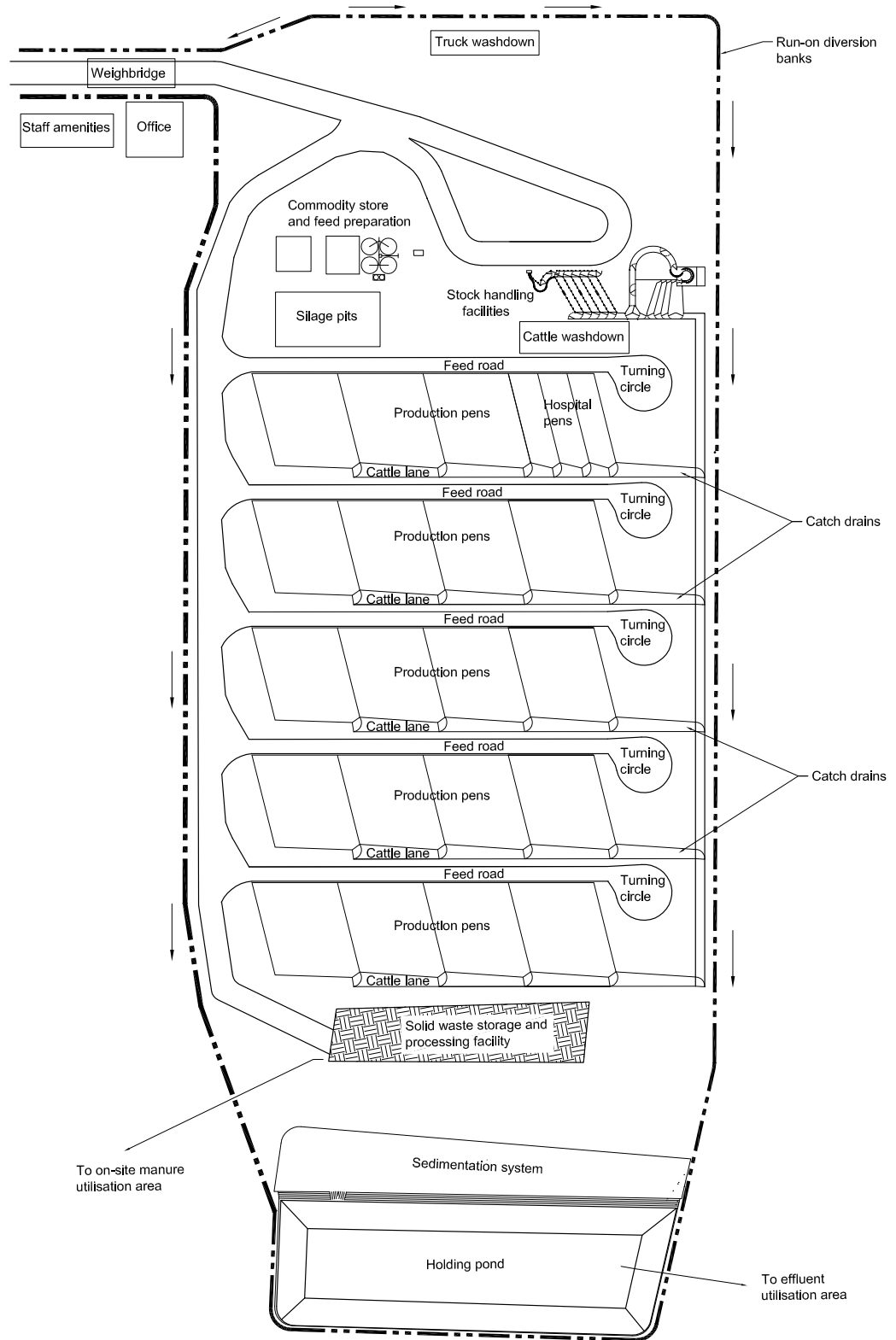

Figure 1. Controlled drainage area for a feedlot

The design layout shown in Figure 1 provides uninterrupted flow for runoff, eliminating the need for culverts.

See Section 2 – Feedlot site layout for further information on feedlot layout.

Design choices

Pen slope

A pen slope of between 2.5% and 6% will ensure quick drainage of rainfall, without runoff scouring excessive amounts of manure from the pen surface. Pen slope is the fall of the pen surface perpendicular to the feed bunk (see Figure 2).

Pen slopes less than 2.5% do not drain well as any imperfection in the pen surface or accumulation of manure will cause rainfall to pond in the pens. This would enhance damage to the pen surface and potential damage to the base material underneath the impermeable manure interface. Wet patches in pens can emit odour at 50 to 100 times the rate of dry pen surfaces. Wet patches also lead to discomfort of cattle and dags on cattle coats.

Pen slopes over 6% are difficult to manage and should be avoided. Runoff after heavy rainfall on steep pens can transport large quantities of manure and even erode the base of the pen surface. In addition to the pens having adequate slope, the drains at the lower end of the pens need slope to drain runoff toward the storage areas (see Figure 2). Drains should not run transversely across the middle of pens as they are difficult to clean and maintain, and often are full of manure.

Steeper bed slopes are possible for drains constructed with well-compacted gravel bases that are resistant to erosion or concrete beds.

Figure 2 shows that when there is a combined pen and drain slope across the site, the maximum pen slope is not perpendicular to the feed bunk. The magnitude of this slope and its angle from perpendicular to the bunk will depend on the relative magnitude of each of the pen and drain slopes. Table 1 shows the maximum slopes for a range of pen and drain slopes. Table 2 shows the angles at which the maximum slopes occur (see Figure 2).

Figure 2. Combination of pen and drain slope

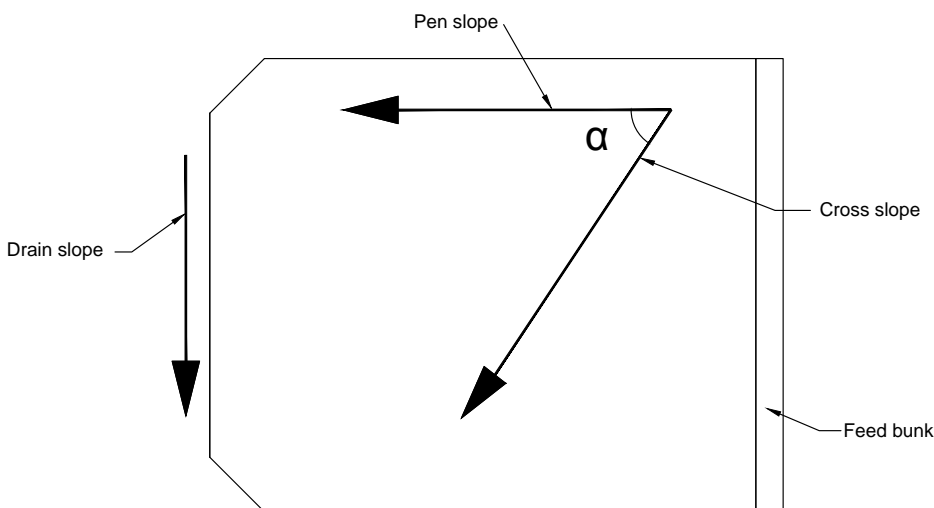

Pens with inadequate pen slope will not drain storm rain.



Ponding of water in feedlot pens with inadequate pen slope.



Drains should not be formed in the middle of the pens as they promote pen to pen drainage. Note how the lower rail on the fence blocks drainage.



Pen to pen drainage is a poor design.

Table 1. Maximum slope for a range of pen and drain slopes.

Pen slope (%)	Drain slope (%)					
	0.50	0.75	1.00	1.25	1.50	1.75
	Cross slope (%)					
2.5	2.55	2.61	2.69	2.80	2.92	3.05
3.0	3.04	3.09	3.16	3.25	3.35	3.47
3.5	3.54	3.58	3.64	3.72	3.81	3.91
4.0	4.03	4.07	4.12	4.19	4.27	4.37
4.5	4.53	4.56	4.61	4.67	4.74	4.83
5.0	5.02	5.06	5.10	5.15	5.22	5.30
5.5	5.52	5.55	5.59	5.64	5.70	5.77
6.0	6.02	6.05	6.08	6.13	6.18	6.25

Table 2. Angle at which maximum slope occurs for a range of pen and drain slopes.

Pen slope (%)	Drain slope (%)					
	0.50	0.75	1.00	1.25	1.50	1.75
	Angle α , degrees					
2.5	11	17	22	27	31	35
3.0	9	13	18	22	27	30
3.5	8	12	16	19	23	27
4.0	7	11	14	17	21	24
4.5	6	10	13	16	18	21
5.0	6	9	11	14	17	18
5.5	5	8	10	13	15	18
6.0	5	7	9	12	14	16

When considering the slope of pens during the design of the feedlot, it is the cross slope that will determine the likelihood of ponding or excessive manure entrapment.

Figures 3a and 3b show typical pen and drain layouts. Although there is a cross slope due to the combination of pen slope and drain slope, little pen to pen drainage occurs whenever pen slope is much higher than drain slope. Where for various reasons drain slope is high, any pen to pen drainage can be eliminated using an angled pen design as shown in Figure 3b.

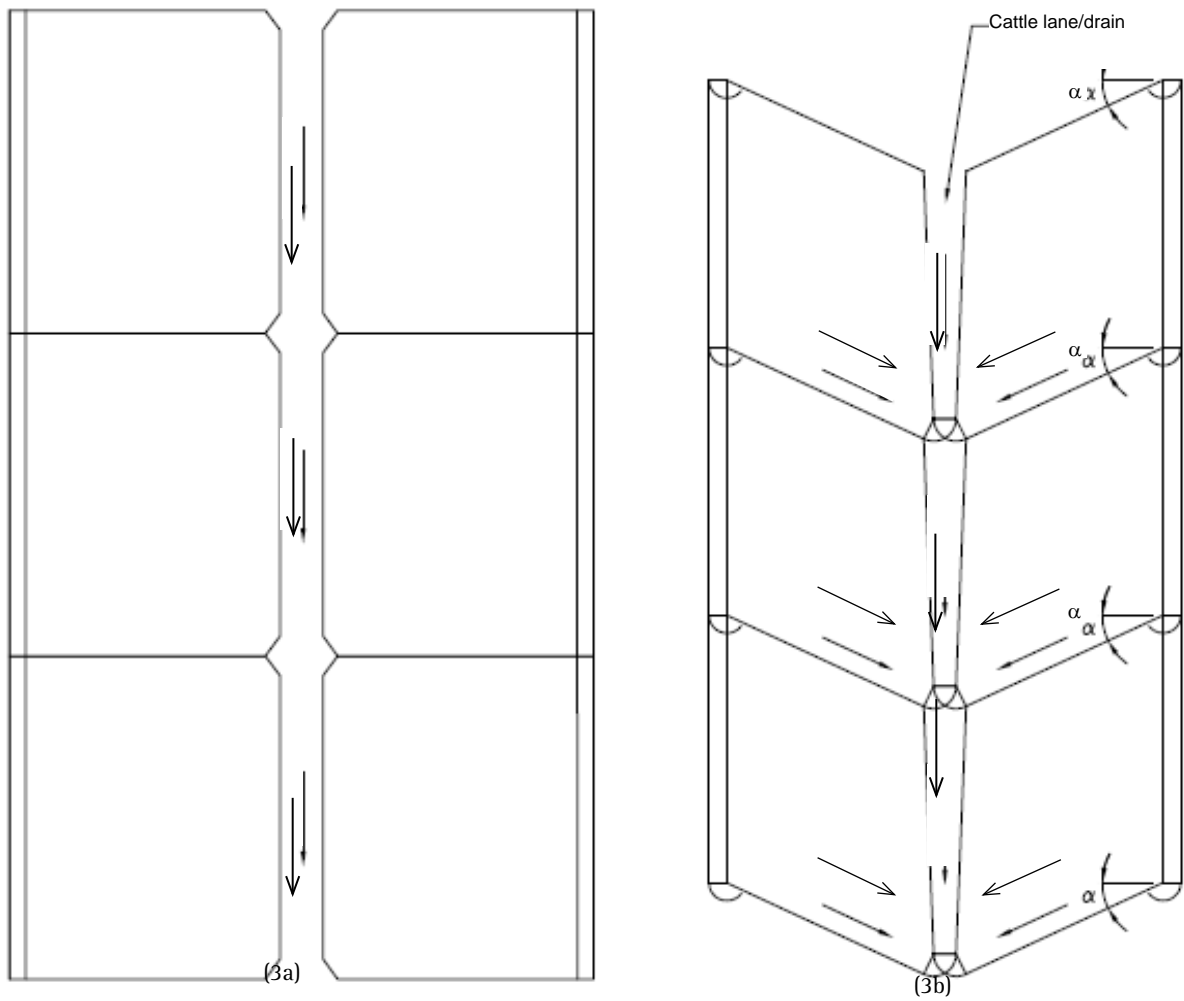

Figure 3. Conventional square pens (3a) vs angled pens (3b) to minimise pen-to-pen drainage



Conventional square pens (as in 3a)



Angled pens to minimise pen-to-pen drainage (as in 3b)



Pen to pen drainage is not desirable. Here a row of pens runs up the slope towards the feed mill with little cross slope. Runoff and manure flows through all pens before exiting at the lower end. This runoff is from a leaking water trough in a pen in the middle of the row.



Pen to pen drainage without good manure management may lead to unacceptable pen conditions. Here, runoff has to flow through each pen towards the manure stockpile.

Drainage design

The function of the controlled drainage system is to convey runoff (and entrained manure) from the pens and other areas to the sedimentation system and holding pond(s). The drains must have sufficient capacity to handle significant storm events and manure loads. The steps involved in designing a drainage system include

1. Determine the location of the drain, including the drain slope.
2. Determine the area and characteristics of the catchment draining into that drain.
3. Determine the design flow rate for that drain.
4. Determine the drain physical characteristics (dimensions, lining characteristics).
5. Calculate the predicted flow depth at the design flow rate and determine if this is acceptable.

Drain location and slope

Within the feedlot, the location of drains is usually determined when the controlled drainage area is laid out. Catch drains below each row of pens and a series of primary drains take runoff from the catch drains to the sedimentation system.

To minimise the settling of solids conveyed in the runoff, the flow velocity in both the catch and primary drains should be greater than 0.5 m/s but not so fast as to cause scouring of the drain.

Where high velocities (i.e. generally >1.5 m/s) are unavoidable, the drain should be lined with an appropriate, durable liner (e.g. compacted gravel, masonry or concrete). Drop structures or energy dissipaters may be installed to reduce the slope and flow velocities in a drain, without having to line the entire length.

Catchment area and characteristics

The next step in drain design is to determine the area draining into the drain and the characteristics of the components of the catchment area. In feedlots, it is usual to break the catchment down into three main sub-components, each of which has different runoff characteristics. They are

- pen area – areas containing cattle and covered with manure
- hard catchment – areas with a high runoff yield including roads, feed alleys, drains, roofed areas and manure stockpiles
- soft catchment – areas with a low runoff yield such as grassed and other vegetated areas within the controlled drainage area.

Design flow rate

Drainage systems are designed to cater for rainfall events of specific frequencies and durations. These frequencies are typically expressed in terms of an average recurrence interval (ARI) which is the average interval between two events of a specific size. Importantly, the interval between two such consecutive events may be greater or less than the average interval; over the long term, however, the average interval between events will approach the ARI.

Commonly used ARIs are 10 and 20 years, the value chosen depending on the assessed consequences of overtopping of the

designed structure. For catch and main drains, a 20-year ARI generally applies and is used in the National Guidelines. The design storm is defined in *Section 12 – Holding pond design* as a rainfall event, with a nominated average recurrence interval (ARI) that has a duration equal to a catchment's time of concentration according to Australian Rainfall and Runoff (Pilgrim 2001).

Diversion banks and/or drains

Uncontaminated upslope runoff should be diverted away from the feedlot controlled drainage area in order to minimise the quantity of runoff requiring treatment. Diversion banks or drains should be designed to carry flow rates resulting from a design storm event with an average recurrence interval of 20 years. Diversion banks and drains should carry flow at a non-scouring velocity which, in practice, means having slopes of <1.5 m/s.

Catch and primary drains

Runoff from the controlled drainage area should initially drain into a collecting drain system, discharge into a sedimentation system and finally, through to holding ponds and/or evaporation systems. Drains should be designed to produce velocities sufficient to transport manure but not sufficient to produce scouring and erosion. Catch drains should be designed to carry, at non-scouring velocity, peak flow rates resulting from a design storm with an average recurrence interval of 20 years, using a runoff coefficient of 0.8.

Design standards

The National Guidelines outline design standards i.e. both diversion banks and drains and catch drains should be designed to carry the peak flowrate resulting from a 20-year average recurrence interval (ARI) design storm. The duration of the design storm should be taken as being equal to the time of concentration of the catchment area; this is the time taken for water to flow from the most remote point of the catchment to the catchment outlet. After this time, runoff from the entire catchment area is contributing to flow at the catchment outlet and should be at a maximum.

Rational method

While other more complex methods are available, it is recommended that the Rational Method (Pilgrim 2001) be used for determining the design flow rate (Q) for feedlot drains. This relatively simple method is widely used in the water engineering field for estimating design flow rates for minor hydraulic structures. This method determines a peak flow of selected average recurrence interval (ARI) from an average rainfall intensity having the same ARI.

In its simplest form, the **Rational formula** is:

$$Q = \frac{C \times I \times A}{360}$$

Where: Q = peak flow rate (m³/s),

C = runoff coefficient,

I = rainfall intensity of 20 yr ARI design storm (mm/hr)

A = catchment area (ha).



With very flat pens, pen to pen drainage may form in the middle of the pens.



Use the ratio of rainfall to surface runoff (runoff coefficient) to calculate for adequate drainage.

Runoff coefficient

To reflect the ratio of rainfall to surface runoff, a runoff coefficient (C) is used. Some suggested ranges for this runoff coefficient for a feedlot controlled drainage area are shown in Table 3 (MLA, 2013b)). The first four catchment types apply to areas upslope of diversion banks and drains (i.e. outside of the controlled drainage area).

The lower values for each of these four catchment types should be applied to low relief catchments that are dominated by overland flow or contour drains, and to catchments having deep sandy soils with high infiltration rates.

Conversely, the higher values for each of the catchment types should be applied to high relief terrain that has well-defined watercourses, minimal surface storage, and rocky, clayey or other poorly absorbent soil; and/or catchments with scant ground cover. Intermediate values should be applied where intermediate conditions exist.

A value of 0.8 for runoff coefficient C can be applied to most feedlot complexes where there are only small areas of grass or other vegetation (soft catchment) within the controlled drainage area.

Table 3. Suggested ranges for the value of the runoff coefficient (C) for a feedlot controlled drainage area

Catchment type	Coefficient (C) range
Forest	0.1–0.6
Pasture/grassland	0.1–0.6
Cultivation	0.3–0.8
Roads	0.9
Residential/industrial	0.4–0.8
Feedlot complex	≥0.8

Rainfall intensity

The generally accepted method for determining the design storm intensity (I) is that provided by Canterford et al. (2001) in ‘Australian Rainfall and Runoff’. Tabulated intensity–frequency–duration (IFD) values are available for major population centres in Australia or calculated online. A variety of software is also available that will calculate values for sites away from major towns and cities. Drains should be designed to carry the peak flow rate resulting from a 20-year ARI design storm.

The duration of the design storm should be taken as being equal to the time of concentration (t_c) of the catchment area. This is the time taken for water to flow from the most remote point of the catchment to the catchment outlet. After this time, runoff from the entire catchment area is contributing to flow at the catchment outlet.

Time of concentration

Several methods are available to determine the time of concentration of a small catchment. Some of these are detailed in Pilgrim and Cordery (1993) and Pilgrim and Doran (2001). There is no definitive method for estimating time of concentration and any appropriate method provided in a recognised text should be acceptable.

One of the more widely accepted methods of estimating time of concentration uses the Bransby Williams Formula, which is given

$$t_c = \frac{58 \times L}{A^{0.1} \times S_e^{0.2}}$$

by:

Where: t_c = time of concentration (min),

L = length of mainstream (km) from the outlet to the catchment divide,

A = area of catchment (km²)

S_e = equal area slope (m/km) as defined in the National Guidelines for Beef Cattle Feedlots (MLA,2012b).

Having established the time of concentration of the catchment, it is then possible to determine the intensity (I) of a 20-year ARI design storm at the development site. This design storm would have a duration equivalent to the time of concentration of the catchment. The Rational Method is then used to calculate design flow rate.

Drain physical characteristics

The drain physical characteristics include cross-sectional dimensions and surface type.

Cross-sectional dimensions

The diversion and catch drains in feedlots usually have either trapezoidal or vee-shaped cross-sections. These two cross-sectional designs are illustrated in the figures below where:

d = flow depth (m),

W = drain bed width (m), and

z_1 and z_2 = drain batters (1 vertical to z horizontal)

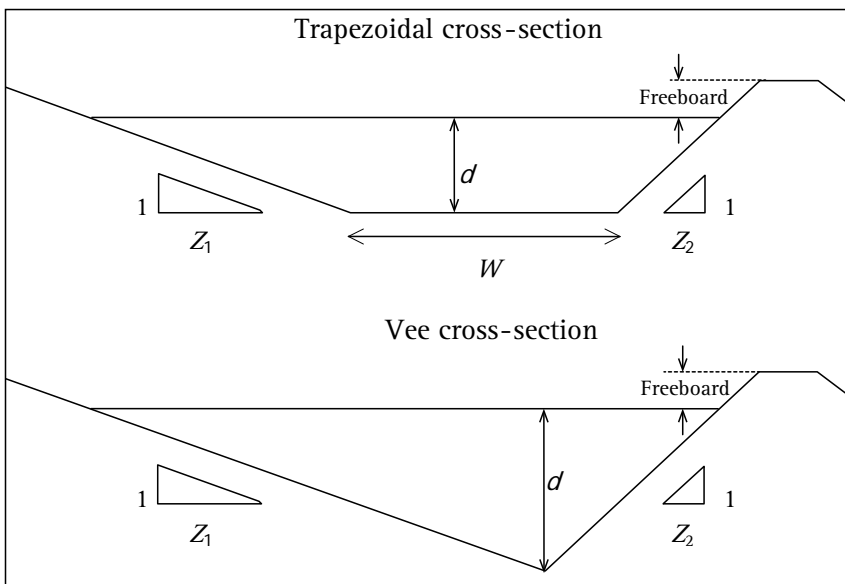

Figure 4 - Typical profiles of feedlot drains (trapezoidal and V-drain)



Concrete drains can be used in steep drain sections to prevent erosion. However, the drain must be wide enough to allow access by cleaning equipment.



Primary drains with vegetation as surface cover are difficult to maintain as they remain wet, the vegetation grows and manure is deposited. These areas can be a source of excessive odour emission and a fly breeding site.

The empirical Manning Formula can be used to estimate flow rates and velocities in drains. The method for estimating the flow rates and velocities in drains is outlined in Appendix A – Design of controlled drainage systems of the National Feedlot Guidelines (MLA, 2012a)

The side batters on drains should in general be no steeper than 1 vertical:2 horizontal ($z = 2$).

All feedlot drains and embankments should have a free board, following post-construction consolidation, of at least 0.15 metres above the design flow depth in a 20-year ARI design storm. To accommodate this freeboard and to allow for variations in embankment height, soil type and construction method, it may be advisable to build embankments 25–40% higher than the estimated requirement.

In catch drains, the freeboard may be provided within the adjoining cattle lane or pen, and it may not be necessary to allow for settling due to soil compaction during construction.

Surfacing of drains

Excessive flow velocities can cause scouring of drains, particularly earthen drains. Some suggested maximum flow velocities in earthen channels with various types of vegetative cover are provided in Table 5.

Where soils are easily eroded, values less than those shown should be adopted. However, as flow velocity values of less than 0.5 m/s are likely to result in excessive sedimentation in feedlot catch and main drains, readily erodible soils should either be dressed with non-eroding soils or lined with an erosion resistant material (e.g. compacted gravel, concrete, or masonry).

Table 5. Recommended maximum flow velocities in earthen channels

Soil cover	Flow velocity (m/s)
Couch and similar low growing stoloniferous grasses	1.5
Mid-height, mat forming grasses	1.4
Native and other culmiferous grasses	1.2
Lucerne	1.2
Annual weeds	0.8
Coarse gravel	1.3 – 1.8
Bare, consolidated, stiff sandy clay	1.3 – 1.5
Bare, consolidated, coarse sand	0.5 – 0.7
Bare, consolidated, fine sand	0.2 – 0.5

Drain design – practical issues

Cross-sectional dimensions

The above calculations are important for main drains where a large catchment area is being drained. However, for small sub-sections of the catchment, the required cross-sectional dimensions required to carry the design flow can be small. In these cases, practical issues determine the cross-sectional dimensions of the drain.

For example, where a cattle lane also serves as a drain, the cross-sectional area of the cattle lane is often larger than the theoretical design dimensions for the drain. Similarly, the bed width of drains is often determined by the width of the machinery used to construct and maintain the drain. Most trapezoidal drains cannot have a bed width less than about 4 m, as construction of an earthen drain with a narrower bed width is impractical.

Surface type

It is generally inadvisable to allow vegetation to grow in either catch or main drains, even though vegetation may resist erosion and thus allow higher design velocities. Vegetation in the drain

- alters the flow characteristics (i.e. impeding flows or increasing the hydraulic pressure and the likelihood of drains overflowing)
- increases manure deposition within the drains
- may be killed in any parts of the drain exposed to extended flows (e.g. during lengthy, low intensity rainfall events).

Where primary drains or diversion banks need to be vegetated, low growing, stoloniferous grasses should be used. Vegetation should be kept short by regular slashing or mowing.

Concrete lined drains can be used in unavoidable steep sections where high velocities would cause erosion. Ideally, a high flow channel lined with concrete or masonry should be used within the vegetated main drain to overcome some of the problems described above.

Upslope diversion drains are usually vegetated or bare earth. They need to provide non-scouring flow velocities. Such diversion drains should be able to safely disperse flows at their discharge points, such that the discharge does not contribute to downslope erosion and does not cause any other significant changes in flow characteristics in stream catchments. This is particularly important where there are other structures (e.g. contour banks, dams, culverts, table drains) nearby and lower in the catchment area.

While it is preferable for diversion drains to be vegetated, the growth should be kept short by regular slashing, mowing or grazing to ensure that flow velocities are within design values.

To minimise the risk of groundwater pollution the catch and main drains must be lined with a low permeability clay or other suitable compactable soil or durable synthetic liner. Clay liners should be of sufficient thickness and layered to ensure that their integrity is not compromised. Repair or replacement of the liner may be necessary from time to time due to wear and tear associated with drain cleaning operations. To protect liners during cleaning operations it may be necessary to overlay the liner with a suitably durable material (e.g. compacted gravel).



A well-maintained concrete drain within a feedlot. The dimensions of this drain allow access for cleaning equipment.



Gravel based drain



Cattle lane and catch drain – Option 1. The cattle lane is not fenced allowing free access by drain cleaning and under-fence pushing equipment. However, extra stockmen may be needed to move cattle.



Cattle lane and catch drain – Option 4. The cattle lane and the catch drain are combined.



Cattle lane and catch drain – Option 2. Runoff passes through the cattle lane into the catch drain. Manure should not be deposited in the cattle lane and the drain can be easily maintained.



Cattle lane and catch drain – Option 3. The cattle lane and the catch drain are combined, but a control bank on the outside of the cattle lane fence keeps runoff in the lane.

Cattle lanes versus catch drains

There are a number of options for a cattle lane and catch drain.

Option 1. The cattle lane is not fenced which allows free access by drain cleaning and under-fence pushing equipment. However, moving stock requires stock handling skills or more stockmen.

Option 2. The runoff passes through the cattle lane into a catch drain that is not fenced. Access to the drain for maintenance is unrestricted and manure should not be deposited in the cattle lane. However, this does require a wider easement than Option 3.

Option 3. The cattle lane and the catch drain are combined but with a control bank on the outside of the cattle lane fence that constrains runoff to stay in the lane. This design can pose problems when moving cattle during wet conditions as they can bog up the drain and restrict flow.

Option 4. The cattle lane and the catch drain are combined; pens are located on either side of the catchment drain/cattle lane and no control bank is required.

Figure 5 shows three possible configurations of cattle lane and associated catch drains.

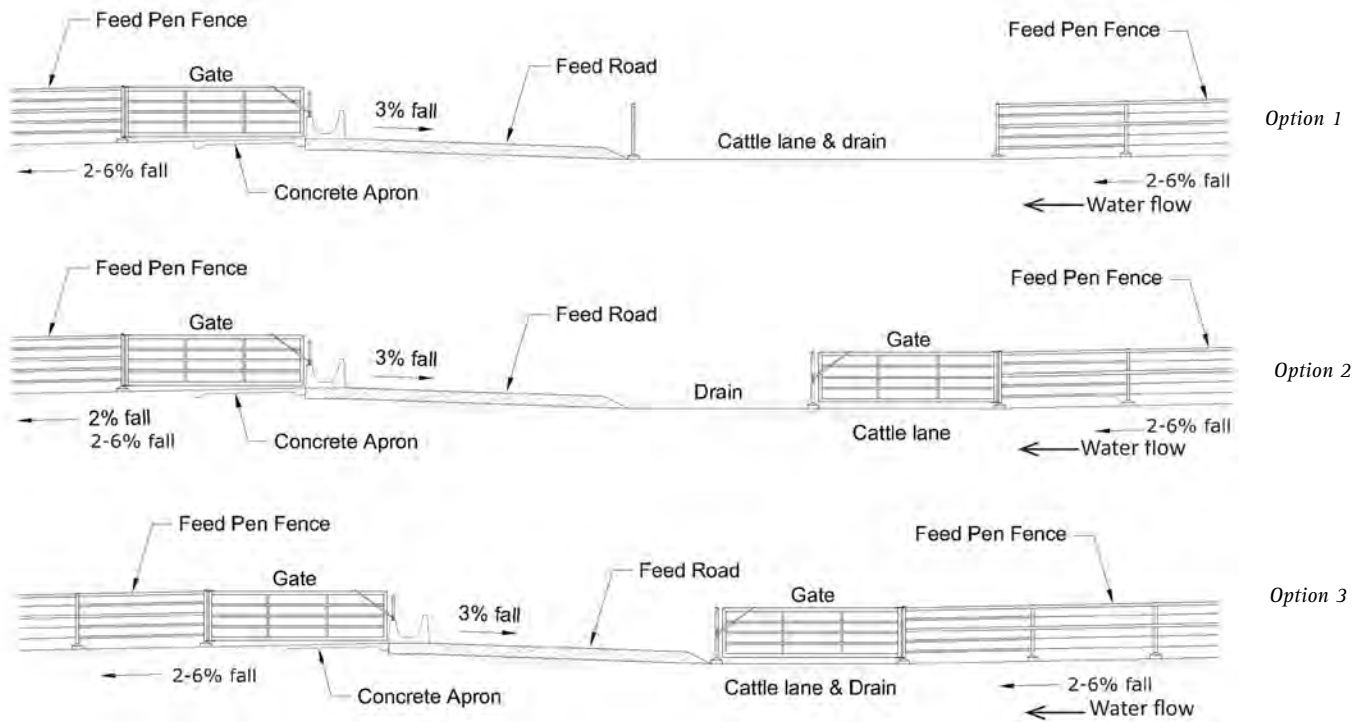

Figure 5. Possible configurations of cattle lanes and catch drains

Culverts and other obstructions

Manure that is entrained in runoff from the pens should remain entrained until it reaches the sedimentation system where settling is expected. Drain obstructions that decrease flow velocity result in the entrained manure being deposited and require unnecessary drain cleaning.

Flow velocity in a drain may be changed by

- culverts (box or pipe)
- changes in grade
- changes in direction
- vegetation

Any possible obstructions need to be designed to maintain flow velocity and prevent manure deposition.



This concrete box culvert allows cleaning of settled manure in the drain on both sides of the culvert.



Grid culvert drain crossing makes it difficult to clean under the grid.



Sediment is deposited when vegetation reduces stormwater flow through culvert.

Drainage of feed roads

Feed roads are part of the catchment within a controlled drainage area. They readily shed rainfall resulting in runoff but this should not be allowed to pond beside the feed bunk. The feed road should be shaped so that runoff drains away from the feed bunk. Figure 6 shows how feed roads should be drained for back to back and sawtooth configurations. Section 9 – Overall pen layout provides information on pen layouts.

Figure 6. Cross section of feed roads showing cross-slopes for drainage.

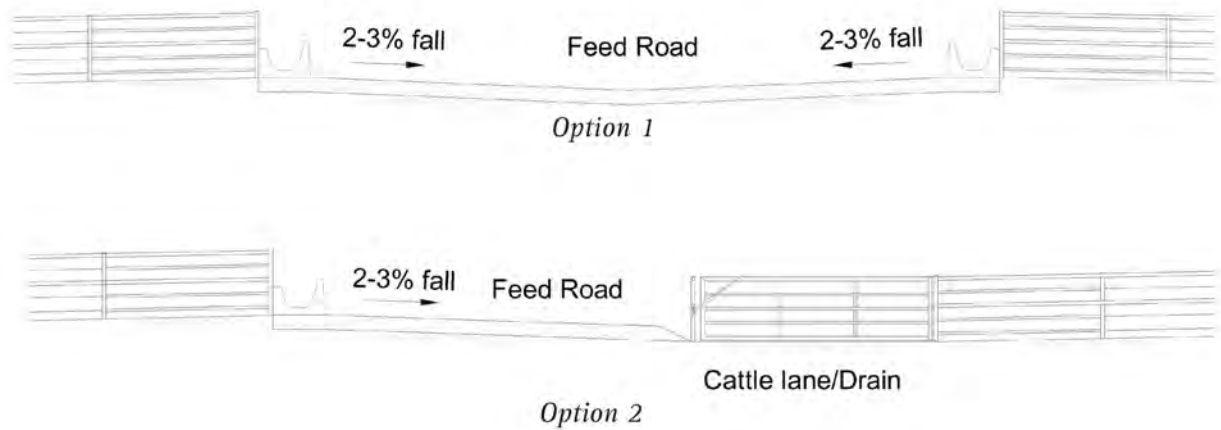

Drainage of feed roads showing slope towards the centre as in Option 1 of Figure 6.



Feed roads need 2–3% slope for adequate drainage.

Further reading

- Canterford, R.P., Pescod, N.R., Pearce, H.J. and Turner, L.H., (2001), Design intensity-frequency-duration rainfall, in 'Australian Rainfall and Runoff', ed. Pilgrim, D.H., Institution of Engineers Australia, Barton, ACT.
- Cordery, I., (2001), Storm losses and design rainfall excess, in 'Design intensity-frequency-duration rainfall, in 'Australian Rainfall and Runoff', ed. Pilgrim, D.H., Institution of Engineers Australia, Barton, ACT.
- Guidelines for the establishment and operation of cattle feedlots in South Australia*, Department of Primary Industries and Resources (SA) and Environment Protection Authority, 2006, Adelaide.
- Guidelines for the Environmental Management of Beef Cattle Feedlots in Western Australia*, Bulletin 4550, 2002, WADo Agriculture (ed.), Western Australia Department of Agriculture, Perth, WA.
- Model Code of Practice for the Welfare of Animals: Cattle*, 2004, 2nd Edition, Primary Industries Report Series 85, CSIRO Publishing/ PISC (SCARM), ISBN: 9780643091498
- National Guidelines for Beef Cattle Feedlots in Australia - 3rd Edition*, Feedlot Industry Accreditation Committee (ed.), June 2012, Meat & Livestock Australia, Sydney, NSW.
- O'Loughlin, G.G. and Robinson, D.K., (2001), Urban stormwater drainage, in 'Australian Rainfall and Runoff', ed. Pilgrim, D.H., Institution of Engineers Australia, Barton, ACT.
- Pilgrim, D.H. and Cordery, I., (1993), Flood Runoff, in 'Handbook of Hydrology', ed. Maidment, D.R., McGraw-Hill, New York, NY.
- Pilgrim, D.H. and Doran, D.G., (2001), Choice of flood estimation method, in 'Australian Rainfall and Runoff', ed. Pilgrim, D.H., Institution of Engineers Australia, Barton, ACT.
- Skerman, A 2000, *Reference manual for the establishment and operation of beef cattle feedlots in Queensland*, Information Series QI99070, Queensland Cattle Feedlot Advisory Committee (FLAC), Department of Primary Industries, Toowoomba, QLD.
- The New South Wales feedlot manual*, 1997, NSW Agriculture, NSW Agriculture, Department of Land and Water Conservation, Department of Urban Affairs and Planning & Environment Protection Authority, Orange.
- Victorian code for cattle feedlots*, August 1995, Victorian Feedlot Committee, Department of Agriculture, Energy & Minerals, Melbourne.



FEEDLOT DESIGN AND CONSTRUCTION

11. Sediment removal systems

AUTHORS: Peter Watts and Orla Keane

Introduction

Sedimentation systems are constructed to capture and detain rainfall runoff, allowing any entrained sediment to 'settle out' before the runoff enters the feedlot holding pond or ponds. The system function is to reduce sediment deposition in the holding pond and remove sediment from the system.

Design objectives

Feedlot sediment removal systems should be designed, constructed, operated and maintained to ensure that

- entrained manure and other solids are removed or 'settled' from the runoff before it enters the holding pond, thereby
 - maximising the active storage volume of the holding pond
 - reducing the probability of holding ponds overtopping
 - reducing the required frequency of sludge removal from the holding pond
 - reducing the biological loading on the holding pond and therefore the intensity and duration of holding pond odour emissions.
- sedimentation systems drain freely, with minimal clogging of the 'control outlet'.
- settled solids dry rapidly, thereby reducing the intensity and duration of sediment system odour emissions.
- contamination of underground water resources by the leaching of runoff below the bed of the sedimentation system is avoided by ensuring that the system is constructed on low permeability soils, or alternatively, sealed with a suitable clay or synthetic liner.
- deposited sediments can be removed from the sedimentation system in a practical, cost-effective and efficient manner.
- in wet areas, more than one sedimentation basin should be built so that one can be drying whilst the other is in use.
- The control weir is capable of discharging the peak flow following a 50-year average recurrence interval (ARI) design storm without the system embankment overtopping.

Mandatory requirements

The National Guidelines for Beef Cattle Feedlots in Australia provide the following design standards for sedimentation systems

- Sedimentation systems should be designed to cater for the peak flow rate from a design storm having an ARI of 1 in 20 years, when applying runoff coefficients of 0.8 for feedlot pens, roadways and other hard areas and 0.4 for grassed areas within the controlled drainage area.
- The maximum flow velocity in the sediment system is 0.005 m/s.
- Flow from the sedimentation system should be regulated by a control weir.

- A minimum freeboard of 0.9 m should be provided between the weir crest and the crest of the sedimentation system embankment. The control weir should be capable of discharging the peak flow from a 50-year ARI design storm without the system embankment overtopping.
- Sedimentation basins and terraces should be capable of free draining down to bed level, and have a bed slope of at least 0.1% towards the control outlet weir to facilitate drainage.
- The sedimentation system should be underlain with at least 300 mm clay or other suitable compactable soil, or a synthetic liner able to provide a design permeability of $<1 \times 10^{-9}$ m/s (~ 0.1 mm/d) and a solid base for maintenance equipment to access the system for sediment removal without damaging the impermeable surface.

Design choices

Sedimentation systems are used for two different wastewater streams in feedlots. The larger sedimentation systems are those that are designed to remove entrained solids in the runoff from the controlled drainage area. As runoff from this catchment is predominantly controlled by rainfall, the inflow to the large sedimentation system is of varying frequency, duration and flow volume, with long periods of no inflow.

The second type of sedimentation system is that used for smaller sub-catchments where a constant wastewater flow occurs, such as cattle handling facilities, cattle washes and truck washes. These basins have a low peak flow rate with a regular inflow.

Three basic types of sedimentation systems are commonly used in feedlots

- sedimentation basins
- sedimentation terraces
- sedimentation ponds

These three types of sedimentation systems are briefly described in the following sections.

Design fundamentals

Outlet control

In all cases, the design principle of the sedimentation system is that solids entrained in the runoff are transported via drains at a high velocity until the runoff enters the sedimentation system where the flow velocity reduces to a very low value. A significant proportion of the entrained and suspended solids settle to the base of the sedimentation system.

Non-settleable solids suspended in the runoff slowly flow into the holding pond via an outlet structure. Rather than acting as a filtering device, the sedimentation system outlet structure is intended to function as a discharge regulator, regulating the outflow and giving the settleable solids the opportunity to settle out in the sedimentation system upstream of the outlet structure.



A large shallow sedimentation basin drying out after storm runoff



One cell of a sedimentation terrace with multiple cells – drying out after runoff



A sedimentation pond (5 m deep) that stays full of liquid. This pond has an inlet weir for incoming sediment and effluent runoff, and an outlet weir to a shallow, large surface area evaporation basin.

Basin configuration

The efficiency of solids removal by the sedimentation system depends greatly on basin configuration. This includes the location of the inlet in relation to the outlet, which influences the flow path across the basin. Ineffective configurations result in poor solids removal. Basin configurations should be selected to suit site characteristics such as topography and the location of inflow points.

Sedimentation basins

These systems are typically wide, shallow storages, having a maximum water ponding depth less than 1 m. They are designed to drain completely (down to bed level) following a runoff event. The bed of the basin should slope towards the control outlet at a gradient of at least 0.1%. Solids are deposited in relatively thin layers over a large area, facilitating rapid drying after the basin has drained of liquid material. The dried solids can then be removed at the earliest possible opportunity.

Sedimentation basins have a large surface area; they are suited only to a site with a large, flat area below the feedlot pens. Sedimentation basins are not suited to steep or confined sites. The surface area of the sedimentation basin becomes part of the catchment area for the holding pond. Machinery must be able to access the base of the basin to gather and remove the dried solids.

Single sedimentation basins are not suitable in areas of high annual rainfall or prolonged winter rainfall. In both situations the basin does not dry out and so wet solids remain in the basin for prolonged periods causing odour. In these areas, there should be at least two basins in parallel so that one basin can be drying before cleaning whilst the other is in use.

Sedimentation terraces

Sedimentation terraces are relatively narrow, shallow basins, having gently sloping bed gradients (approximately 0.1 to 0.5%). Two or three terraces are commonly constructed in series, separated by control weirs similar to those provided in basins. Depending on the terrain, drop structures may be incorporated into the control weirs when there is a significant difference in bed elevation between consecutive terraces.

Similar to sedimentation basins, terraces are designed to drain completely, down to bed level, following a runoff event. Solids are deposited in relatively thin layers promoting rapid drying. Cleaning operations are generally similar to those for sedimentation basins. Sedimentation terraces are suited to steep sites where large, flat areas are not available. By using a series of cells and a drop structure at each cell, a large vertical drop from the pens to the holding pond can be managed.

Sedimentation ponds

Sedimentation ponds are designed to retain some runoff at all times and not intended to drain completely following runoff events. They are generally greater than 1.0 m deep although shallow ponds have sometimes been used. Generally, at least two ponds are required in parallel so that one pond can be isolated for drying before cleaning whilst the other pond is in use. Solids settle to the bottom of the

sedimentation pond, which must be desludged at regular intervals. Some sedimentation ponds usually use earth or grassed bywashes rather than control weirs to discharge runoff into the holding ponds.

Sedimentation ponds should be designed to enable desludging using an excavator. This can be achieved by having a high length to width ratio to allow for access by an excavator along the banks of the basin. It should be noted that because sedimentation ponds retain liquid and contain decomposing manure, they are a potential source of odour. The earthworks for the sedimentation ponds are constructed under the design criteria laid out for holding ponds in Section 12.

Typically, sedimentation ponds are used in high rainfall climates with frequent runoff or winter-dominant rainfall zones.

Outlet control

Control outlets should be designed to temporarily retain effluent within the sedimentation system. They regulate the discharge from the sedimentation system into the holding pond and safely discharge flows in excess of the design flow. Well-designed control outlets allow liquid effluent to drain freely from the entire depth of the settled sediment down to the bed of the basin or terrace, enabling easy removal of sediment during cleaning.

The following basic types of control outlets are currently being used successfully at feedlots in Australia

- horizontal timber drop-board weir
- vertical timber weir
- single vertical slot throttle weir

Figure 1 shows a plan view and cross section detail views of a typical design of a horizontal timber drop-board weir structure, including the block wall and board retainers. Detail 1 shows how the boards are chamfered in the direction of flow to allow remaining sediments to move freely through the weir to prevent clogging. The top of the weir boards is lower than the concrete block sidewall to allow high level discharge over the weir following major rainfall (see Figure 5).

In this type of weir, the horizontal drop-boards are wedged apart to enable the liquid effluent to drain from the sediment deposited on the upstream side, and the gaps may be altered by installing different sized wedges. Timber slatted control weirs are effective, low cost and do not rely on human intervention to work efficiently.

Figure 2 shows the vertical timber weir. This type of weir incorporates a series of hardwood timber slats mounted vertically across a reinforced concrete structure constructed in a basin or terrace embankment. The gaps between the slats extend down to the bed of the basin or terrace to allow the entire depth of sediment to drain. Well-designed vertical timber weirs are less likely to require manual manipulation to enable the entire depth of sediment to drain.

Figure 3 shows the single vertical slot throttle weir. The sole purpose of this weir is to slow the runoff so that entrained manure can settle out. All liquid and some solids will pass through the slot.



Horizontal timber slat control weir after a storm, with floating material retained in the sedimentation basin.



Horizontal timber slat control weir showing deposited sediment on the upstream side with little manure on the downstream side. The basin has drained completely and is drying out so that the solids can be removed.



A single row vertical timber weir, with no overtopping freeboard

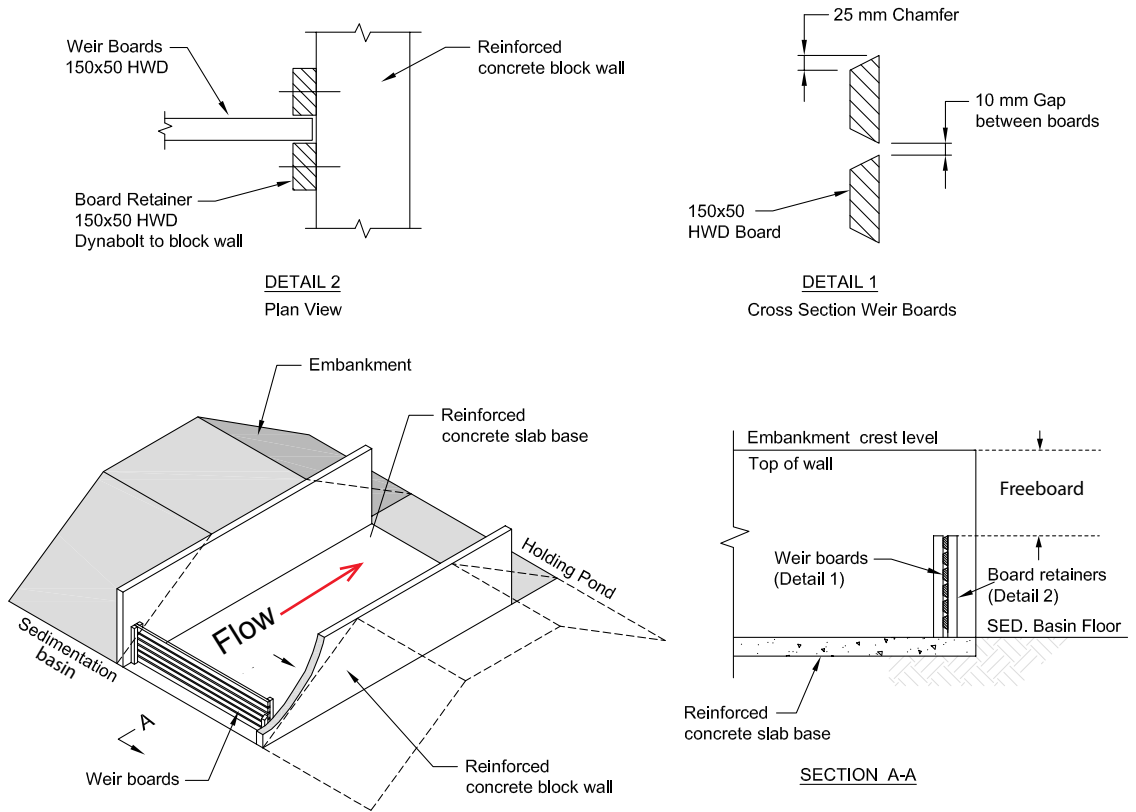

Figure 1. Typical horizontal timber drop-board weir



Typical vertical timber board weir, incorporating two rows of drop-boards and reinforced concrete base.

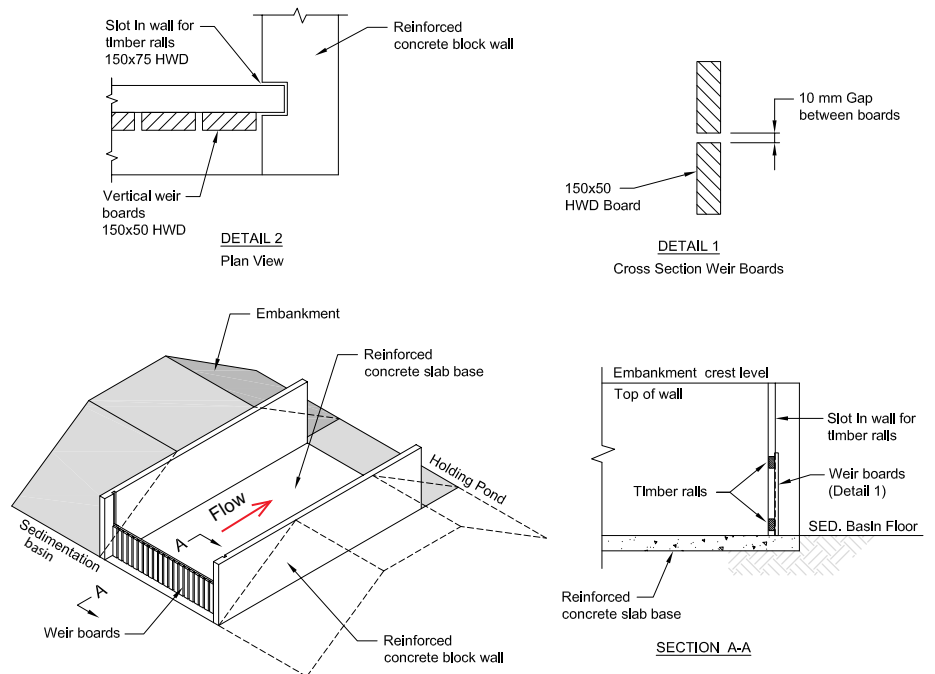

Figure 2. Typical vertical timber weir

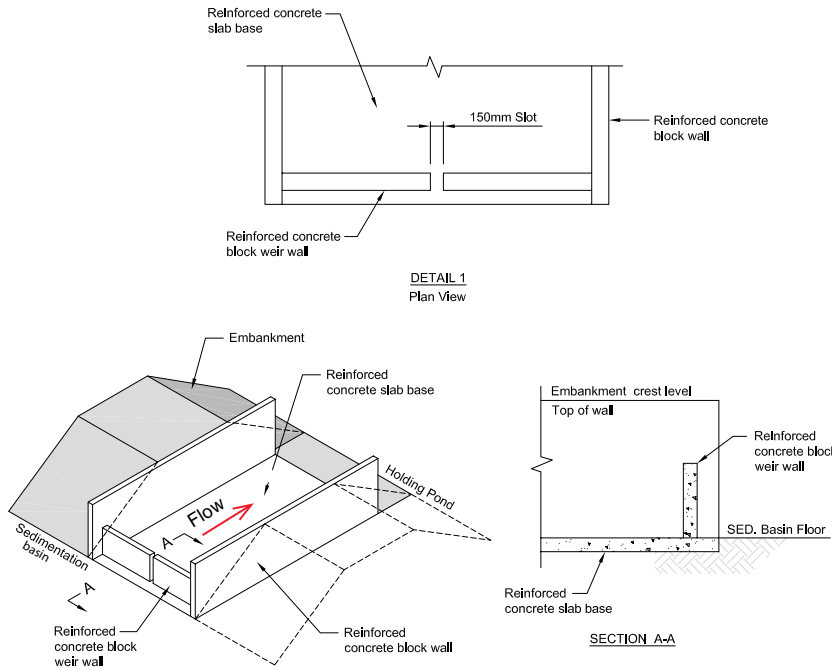

Figure 3. Typical single vertical slot throttle weir

Sedimentation system configuration

The shape of the sedimentation system and the relative position of the inlet and outlet have a major effect on the performance of solids removal. Even though the length to width ratio is important, aspects such as inlet and outlet location and channelling due to vegetation or bed topography have major impacts. The following design aspects can affect the hydraulic conditions which often characterise the complexity of various sedimentation systems

- bed shape (i.e. flat or angled bottom)
- configuration (i.e. island, internal berms)
- depth
- length to width ratio
- shape (i.e. curved, circular, triangular or rectangular)
- baffles or channels/flumes
- inlet and outlet weir control location and type.

One of the key factors in sedimentation system design is to account for the configuration of the system (location of inlet and outlet structures, shape) and the effects of the different configurations on settling efficiency directly relating to the ability of the system to short circuit. Different configurations can be described by a parameter known as Hydraulic Efficiency (η) (Persson et al. 1999).

Figure 4 shows 13 hypothetical sedimentation system configurations with no vegetation and each having the same surface area.

The hydraulic efficiencies of these systems have been evaluated on a scale ranging from 0 to 1, with 1 representing the best hydrodynamic conditions for sediment removal. A subsurface berm, baffle or island placed in front of the inlet improves hydraulic performance by minimising short-circuiting and increasing the effective volume and degree of mixing. In Figure 4, cases P and O contain an island;



A vertical slot weir used in a sedimentation terrace



A drop weir structure on a sedimentation basin relies on human intervention for use. Thus the operation of the system can be stalled if workers cannot reach the sedimentation system as during flooding.



A typical horizontal timber drop-board weir. There should be a minimum freeboard of 900 mm between the control weir crest and the crest of the sedimentation system embankment.

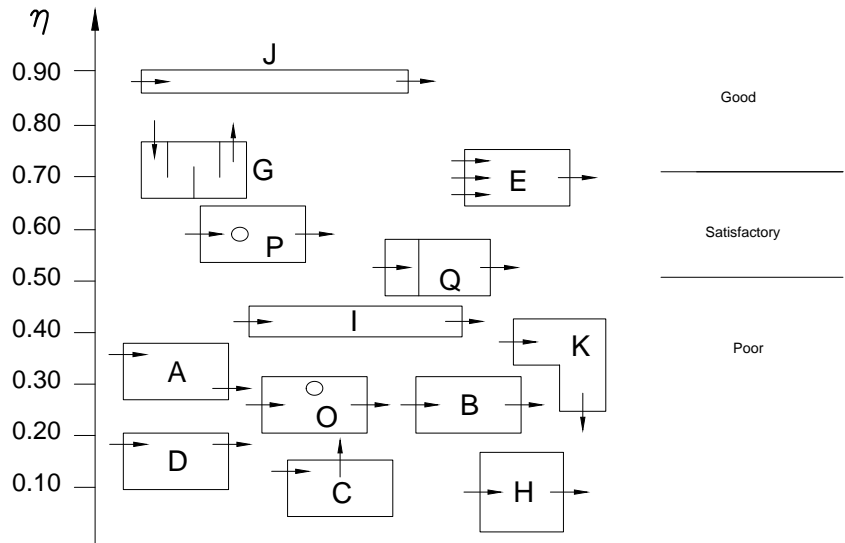

Figure 4. Hydraulic efficiency of different shapes and configurations of sedimentation basins



Rock-filled weirs are a poor design choice as they clog easily.

Case Q has a sub-surface berm; Case G has 3 berms; Case J is effectively a sedimentation terrace. The locations of the inlets and outlets have a considerable impact on the performance of solids removal. Maximising the flow path length between them is critical for achieving high hydraulic retention and good settling characteristics. Sedimentation systems should be designed to have a value of not less than 0.5 and appropriate layouts can be adopted from Figure 4.

Higher values of hydraulic efficiency (λ) indicate sedimentation systems having more effective settling performance. If the basin yields a lower value, modification to the basin configuration should be explored to increase the value (e.g. inclusion of baffles, islands or flow spreaders). As a guide, hydraulic efficiency above 0.7 is considered good, between 0.5 and 0.7 is considered satisfactory and less than 0.5 is considered poor.

Consideration of access to a basin for cleaning/maintenance is crucial when designing the structure as this may impact the shape and configuration.

For example, if a sedimentation system with a configuration similar to configuration H is used in a feedlot, the hydraulic retention could be improved by including internal berms (such as in configuration G). The inclusion of berms should be designed such that an excavator would be able to use them for maintenance and removal of sediment.

Sediment removal system design process

The steps in the design of the sediment removal system are

Step 1

Assess the characteristics of the proposed sediment removal system site, including topography, available spatial area, soil types, location of above and below ground services, potential runoff inflow points and access points for sediment removal equipment.

The choice and configuration of the site for the sediment removal system may be flexible for a greenfield site, but not for an existing site where spatial constraints may limit the available area between the existing feedlot pens and the holding pond. In this case, a

sedimentation pond may be a preferred option as a larger volume can be obtained with a smaller footprint. Sediment removal equipment must have access.

Step 2

Choose the most appropriate type of sediment removal system (basin, terrace or pond) depending on local climate and location characteristics.

Step 3

Assess the need for more than one sediment removal system. Wet manure is difficult to handle and there are problems with its subsequent storage and use. In higher rainfall areas, two sedimentation basins in parallel may be preferable so that one can be drying out prior to cleaning whilst the other one is in use.

Step 4

Determine the length/width (L/W) ratio for the configuration to maximise the flow path within the sediment removal system so as to maximise sediment deposition (see Figure 4). The location of inflow points in relation to the outlet control weir is important to maximise settling. Sediment dewatering may need to drain back into the basin, thus affecting the footprint area required for a sedimentation basin.

Propose a footprint for the sediment removal system, taking into account the optimal configurations from Figure 4.

Step 5

Having proposed a configuration to maximise settling, calculate the length to width ratio to determine the settling volume.

Step 6

Determine the area and characteristics of the controlled drainage area catchment flowing into the sediment removal system. The controlled drainage area is discussed in *Section 10 – Pen and drainage systems*.

Step 7

Calculate the peak inflow rate for a 20-year ARI storm. A procedure for calculating the design inflow rate for a given ARI storm is provided in *Section 10 – Pen and drainage systems*.

Step 8

The sedimentation system should be designed to deposit solids settling at a maximum flow velocity of 0.005 m/s. The volume required to achieve settling at the required velocity is determined by using the following formula:

$$V = Q_p \cdot L/W \cdot \left(\frac{\lambda}{v}\right)$$

where

V = sedimentation system design volume (m³)

Q_p = peak inflow rate for a design storm with an average recurrence interval of 20 years

L/W = length to width ratio, where L is the length along the direction of flow

λ = a scaling factor

v = flow velocity (m/s): maximum = 0.005 m/s



A view upstream of the sedimentation system showing the drainage line from the pens to the sedimentation system. The drains run under an on-site roadway, through a concrete culvert that permits the uninterrupted flow of effluent to the sedimentation system.

Lambda (λ) is a scaling factor that accounts for sediment accumulation and removal frequency. Values for lambda are set out in Table 1 for each of the three types of sedimentation systems.

Table 1. Scaling factors

Sedimentation system	L/W	λ
Basins	2–3	2.5
Terraces	8–10	1
Ponds	2–3	6



Sediment basin effectively retaining sediment and draining to bed level, allowing deposited solids to dry.

Step 9

Determine the required storage depth from the required cross-sectional area of flow and footprint area. The depth required is usually not equal to the design volume divided by the footprint area as it does not take into account the height and volume occupied by side batters for the storage. This can be significant for a deep storage.

Step 10

Sedimentation systems (other than ponds) should preferably be built with temporary storage depths less than 1.0 m. If the calculated depth exceeds 1.0 m, either the foot print area needs to be increased or if this is not possible, a sedimentation pond option should be considered. The design of a sediment removal system should also provide for adequate storage for settled sediment to prevent the need for frequent sediment removal. This provision needs to be added to the volume calculated in Step 7. Sedimentation systems should be cleaned as required to maintain their designed dead storage capacities and to ensure operational efficiency. However, having to clean more frequently than once a year can pose problems in selecting a time with suitable weather conditions.

Step 11

Determine the area and characteristics of the controlled drainage area flowing out of the basin (i.e. area from Step 5 plus the surface area of the basin).

If a large, shallow sedimentation basin is being designed, the controlled drainage area at the outlet may be considerably larger than the controlled drainage area at the inlet. Heavy rainfall falling onto the basin itself contributes to the outlet flow.

Step 12

Using the area in Step 10, determine the peak outflow rate for a 50-year ARI storm. The calculation of the peak flow rate is discussed in Section 10 – Pen and drainage systems.

Step 13

Using a freeboard of 0.9 m, determine the required width of an outlet weir capable of carrying the outflow resulting from a design storm. For a sedimentation pond this is the width of the outlet structure.

The required width of the weir can be calculated using the broad crested weir formula below and the peak flow from Step 12.

$$b = \frac{Q}{C_d \times h^{3/2}}$$



Sediment has built up between the walls of this control outlet as there is insufficient space for maintenance equipment to reach it. The control structure should have been located at the end of the block wall structure.

where

b = width of outlet weir (m)

h = depth of water above the crest of the outlet weir (m)

Q = peak flow rate (m^3/s)

C_d = weir coefficient (1.66)

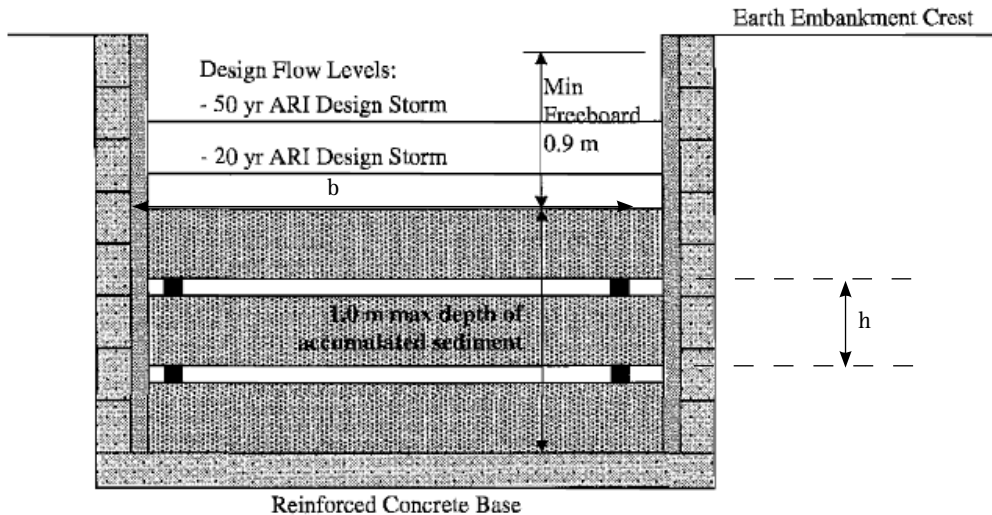

Figure 5. Details of outlet weir dimensions (Skerman, 2000)

A minimum width of 2.5 m is recommended to allow access by cleaning machinery. Ensure that effluent stored in the holding pond does not back up into the sedimentation system. The top water level of the holding pond (bywash level) should be at least 0.3 m lower than the bed of the outlet weir.

Cleaning, maintenance and de-silting

Maintenance of the sedimentation system is always central to its operation. Sedimentation systems treat runoff by slowing flow velocities and promoting coarse to medium-sized sediments to settle. Maintenance involves ensuring that the outlet is not blocked with debris and that sediment deposition is not substantially reducing the active volume of the sedimentation system, which results in excessive odour emission and poor settling performance.

Accessibility for maintenance is an important part of design. Figure 6 illustrates critical dimensions for an excavator. If an excavator is able to reach all parts of the basin from the top of the bank/batter/berm, an access ramp may not be required; however, the need for an access track around the perimeter of the basin will affect the overall earthworks design.

If sediment collection requires earthmoving equipment to enter the basin, a stable ramp having a gradient not greater than 1 vertical: 10 horizontal will be needed to access the base of the sedimentation basin. In this case, sedimentation basins should be constructed with a hard (i.e. rock/gravel) base, with a bearing capacity sufficient to support maintenance machinery when access is required within the basin.

Apart from protecting the impermeable base of the structure, this feature assists excavator operators in detecting when they have reached the base of the basin during de-silting operations.



Upstream of the outlet control structure. Excessive removal of sediment has caused the floor of the basin to be lower than that of the control structure so the basin cannot fully drain. When removing sediment, do not alter the base of the sedimentation structure.

Sedimentation basins and terraces should be capable of draining by gravity down to the base level.

Inspections of the inlet configuration following storms should be made soon after construction to check for erosion. In addition, regular checks for sediment buildup will be required as sediment loads from developing new catchments vary significantly.

The National Guidelines for Beef Cattle Feedlots state that sedimentation terraces and basins should be cleaned as soon as practicable after significant material builds up. A desirable frequency of basin de-silting is generally triggered when sediment accumulates to half the basin depth. Debris and sediment should be inspected regularly and debris removed before it blocks inlets or outlets.

Pen (box) scrapers are ideal for removing sediment from dry sediment basins because they can accurately maintain bed gradients that promote good drainage. Other suitable machinery includes graders and front end loaders.

A compacted gravel base in the basin will allow cleaning machinery to operate under wet conditions and will protect the impermeable layer. If the individual cells of a basin, terrace or pond are constructed no wider than about 20 m, sediment can be removed efficiently using an excavator working from the banks. For larger systems, a tracked excavator may be suitable for working within the system as long as conditions are relatively dry.



The excavator must have suitable reach and digging depth.

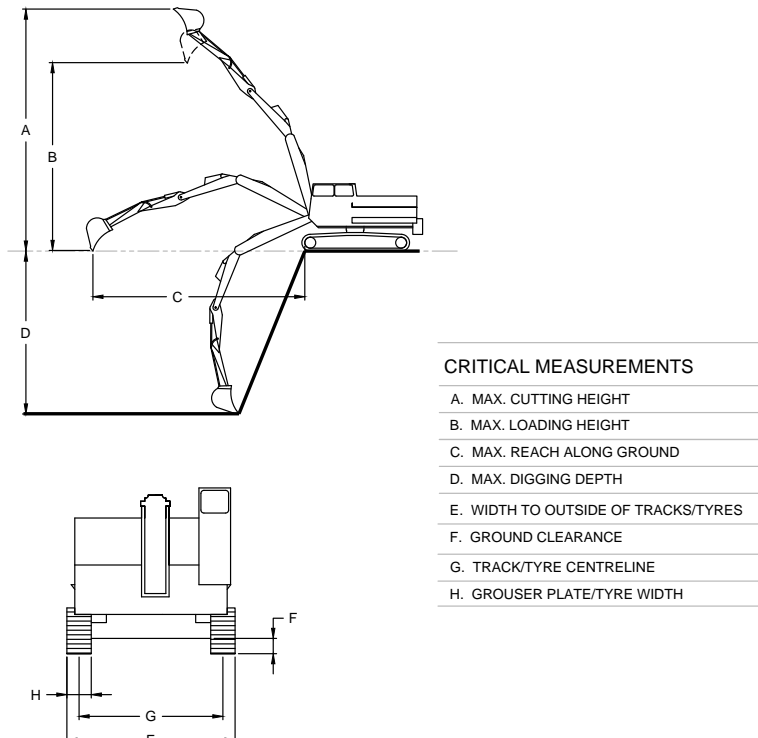

Figure 6. Critical dimensions of excavator for cleaning

Operational maintenance

Operational maintenance is the level required to minimise the risk of major structural component and/or flow control failure, and to ensure that the facility continues to function as designed. Neglecting maintenance could cause sediment to build up, resulting in odour nuisance or embankment failure and subsequent property damage. Neglected maintenance often causes a facility to cease functioning as per the original design, with flow rates exceeding 0.005 m/s.

A program of scheduled periodic inspection of the sedimentation system is essential for early recognition of the need for potential maintenance. The following actions should be performed periodically and preventive or corrective measures undertaken as required

- Routine inspection of the sediment removal system to identify depth of sedimentation accumulation, damage to the batters, scouring or sediment build up (after first three significant storms and then at least every three months).
- Routine inspection of inlet and outlet points to identify any areas of scour, sediment build up and blockages.
- Removal of sediment during dry periods after a rain event, or as required.

The date and nature of the inspection, maintenance and cleaning performed should be recorded to assist ongoing management and to demonstrate responsible operating practices.

After a heavy storm, any possible erosion and any other damage should be checked.

Volume maintenance

One of the most important variables in the design of a sedimentation facility is the volume available for the storage of sediment. If a sedimentation system is allowed to accumulate sediment and debris, this will decrease the storage volume and the ability of the system to function as designed can be greatly reduced. Therefore, it is essential to maintain the design volume by cleaning. In the case of a sedimentation basin it is recommended that that some depth marker be installed in the basin to indicate the maximum level for silt buildup.

Avoiding contamination of groundwater

If a geotechnical assessment of the site suggests a high risk of contamination of underground water resources because of leaching of contaminants, the administering authority may require the installation of a clay or synthetic lining in the bed and batters of the sedimentation system. Clay lining is considered in *Section 12 – Holding pond design*.



Maintenance of the base of the sedimentation system with a box scraper. Dual sedimentation structures before the holding pond will allow one to be de-silted while runoff is diverted to the other.



Cleaning out a sedimentation basin in relatively wet conditions is not desirable as wet sludge is difficult to handle, store and will not dry out.



Marker indicating sediment buildup. The level of buildup can be seen when water is released through the drop weir.



Solids have been effectively controlled. Now the system needs cleaning immediately.



Where possible, solids and larger suspended matter should be removed from the effluent stream from hospital pens, cattle washing facilities and induction facilities with a coarse screen before the settling pond. The base of this area should be large enough to allow maintenance equipment to remove the settled sediments.

‘Small catchment’ sedimentation basins

The local catchment area of cattle handling, cattle wash and/or vehicle washdown facilities can have a separate sediment basin to capture and retain sediment. Most runoff into these sediment basins is from cleaning water, rather than rainfall.

These sediment basins may be non-trafficable or trafficable.

The non-trafficable types are typically in ground tanks, conventional ‘box’ shaped concrete pits or longitudinal drains with grates.

Trafficable types allow the material collected in the pit to be cleaned out with the cleaning machinery entering the basin.

The sedimentation basin should be located to the side of the washdown area and not covered by a grate, to allow easy access for machinery to remove sludge.

The sediment basin should drain completely to bed level so that the basin can dry out and be cleaned to prevent potential odour. Often, dual basins allow the first basin to dry out and be cleaned when inflow is diverted to the second basin.

The factors to be considered when designing trafficable sedimentation basins include

- volume of wastewater generated and the required wastewater storage volume
- materials for construction
- vehicular access
- drainage
- cleaning frequency
- depth and slopes, relative to other components of the wastewater management system
- physical management of the sludge and solid waste disposal
- equipment available for cleaning
- pumping, or gravity release of wastewater
- configuration of weeping wall/bar screen

Designs need to take into account the specifications of the vehicles needed to clean the sediment basin, with the ramp large enough for easy access and manoeuvrability when cleaning. The recommended grade of access ramps is 1 in 10 even for 4WD tractors.

The width of the sediment basin is set by the width of the cleaning vehicle and loader bucket. Table 2 provides typical bucket widths of machinery commonly used at feedlots. For large vehicles, allow at least 100–300 mm either side of the bucket for sideways movement during cleaning.

Table 2. Typical bucket widths of various equipment

Equipment	Bucket width (mm)	Allowance (mm)	Total width (mm)
Skidsteer loader			
35 kw (47 hp)	986 (39")	150	1136
53 kw (71 hp)	1134 (45")	150	1284
70 kw (95 hp)	1386 (55")	300	1686
Tractor front end loader			
37–60 kw (50–80 hp)	1500–1800 (59–70")	300	1800–2100
52–75 kw (70–100 hp)	1800–2100 (70–83")	300	2100–2400
76–112 kw (100–150 hp)	2100–2400 (83–95")	300	2400–2700
112–150 kw (150–200 hp)	2100–2400 (83–95")	300	2400–2700
Backhoe loader			
65 kw (88 hp)	2262 (89")	300	2562
75 kw (98 hp)	2350 (92")	300	2650

Sediment basins should also have some type of grooving on concrete entry ramps to provide better traction, as they have a tendency to become slippery.



A double-sided trafficable solids basin at a truck wash facility



Effluent can be diverted into one side of the basin so that the other side can dry out and sediment be removed.

Further reading

- Chow, V. Y. (1959) *Open Channel Hydraulics*. McGraw Hill Inc., New York.
- DIP (2006). “Water sensitive urban design – Developing design objectives for water sensitive urban development in South East Queensland.” Department of Infrastructure and Planning (DIP).
- Guidelines for the establishment and operation of cattle feedlots in South Australia, Department of Primary Industries and Resources (SA) and Environment Protection Authority, 2006, Adelaide.
- Guidelines for the Environmental Management of Beef Cattle Feedlots in Western Australia, Bulletin 4550, 2002, WADo Agriculture (ed.), Western Australia Department of Agriculture, Perth, WA.
- Henderson, F. M. (1966) *Open Channel Flow*. Macmillan, London.
- Jobling, G. A., 1943-1982, Horton, A. J and Queensland Water Resources Commission. *Farm Water Supplies Section Farm water supplies design manual. Volume III(2nd ed)*. The Commission, Brisbane, 1984
- Lott, S.C. and Skerman, A.G., 1995. ‘Design of feedlot sedimentation basins.’ Proceedings of the Feedlot Waste Management Conference, Royal Pines Resort, Queensland, 12-14 June.
- Lott, S.C, Loch, R.J. and Watts. P.J., 1994. ‘Settling characteristics of feedlot cattle faeces and manure.’ *Transactions of the ASAE*, 37(1): 281-285.
- National Guidelines for Beef Cattle Feedlots in Australia - 3rd Edition, Feedlot Industry Accreditation Committee (ed.), June 2012, Meat & Livestock Australia, Sydney, NSW.
- McAuley, A. (2009). *Water Sensitive Urban Design (WSUD) Technical Design Guidelines*. Darwin, NT, Northern Territory Department of Planning and Infrastructure.
- Persson, J., Somes, N.L.G. and Wong T.H.F., 1999, Hydraulic efficiency and constructed wetland and ponds, *Water Science and Technology* Vol 40 No 3 pp 291-289.
- PISC (SCARM) (2002). *National guidelines for beef cattle in Australia. SCARM Report 47*. Collingwood, Vic., Primary Industries Standing Committee, Standing Committee on Agriculture & Resource Management.
- Skerman, A 2000, *Reference manual for the establishment and operation of beef cattle feedlots in Queensland*, Information Series QI99070, Queensland Cattle Feedlot Advisory Committee (FLAC), Department of Primary Industries, Toowoomba, QLD.
- The New South Wales feedlot manual, 1997, NSW Agriculture, NSW Agriculture, Department of Land and Water Conservation, Department of Urban Affairs and Planning & Environment Protection Authority, Orange.
- Victorian code for cattle feedlots, August 1995, Victorian Feedlot Committee, Department of Agriculture, Energy & Minerals, Melbourne.



FEEDLOT DESIGN AND CONSTRUCTION

12. Holding pond design

AUTHORS: Peter Watts and Orla Keane

Introduction

Stormwater runoff from the controlled drainage area of a feedlot is normally characterised by high concentrations of organic matter. Even though it has passed through a sedimentation system, it still contains substantial levels of organic matter, nutrients and salts. This runoff should not be allowed to flow uncontrolled into the external environment and should be captured by the holding pond(s).

A holding pond is located at the lower end of the controlled drainage area, immediately below the sediment removal system. It is designed to capture and store the runoff from the controlled drainage area until it can be sustainably utilised.

Applying holding pond wastewater to land where it is sustainably utilised by crops and soil is generally the preferred form of wastewater management. Sometimes in arid areas, without access to other irrigation water and where cropping is not sustainable, evaporation of the wastewater may be acceptable. However, regulatory authorities will generally require feedlot operators to demonstrate that the saline residue remaining after evaporation can be safely utilised or disposed of. Where evaporation is the sole or primary disposal mechanism for wastewater and where captured effluent is not normally applied to land, these ponds are typically referred to as evaporation ponds.

Design objectives

Holding ponds are designed to

- store stormwater until the collected wastewater is either applied to land or evaporated
- be large enough to temporarily store effluent from major storms and/or extended wet periods which limit irrigation or evaporation of effluent, and have sufficient capacity for safe storage of the captured wastewater, limiting overtopping to an acceptable and approved frequency
- be constructed so that their base and internal embankments have a low permeability, thereby minimising the risk of groundwater contamination by leaching of effluent
- be structurally stable, thereby limiting the probability of embankment failure with uncontrolled release of large quantities of effluent and resultant surface water and/or groundwater contamination
- minimise odour emissions, with suitable management.

Mandatory requirements

Compliance with

- Relevant Commonwealth, state and local authority codes, regulations and relevant Australian standards as applicable to feedlot development.
- National Beef Cattle Feedlot Environmental Code of Practice (MLA, 2012b).
- National Guidelines for Beef Cattle Feedlots in Australia - 3rd Edition. (MLA, 2012a). These guidelines state that holding ponds should have sufficient storage capacity so that

- Normal holding ponds (i.e. those from which wastewater is routinely extracted for land application) spill no more frequently than an average of one in 10 years.
- Evaporation ponds (i.e. those from which there is normally no land application of captured wastewater) spill no more frequently than an average of one in 20 years.
- The holding pond should have a spillway or bywash capable of discharging the peak flow from the controlled drainage area from a 50-year ARI design storm.
- A minimum freeboard of at least 0.9 m should be provided between the crest of the discharge weir and the crest of the holding pond embankment.
- The holding pond should be underlain by a minimum of 300 mm clay or other suitable compactable soil, or by a synthetic liner able to provide a design permeability of $<1 \times 10^{-9}$ m/s (~ 0.1 mm/d).

Design choices

Siting

The holding pond must be sited and constructed to protect groundwater, surface water quality, riverine ecosystems and community amenity. The following criteria can be used as a guide

- Holding ponds should not be sited in a location that is inundated by floodwater, on average more frequently than once in every 100 years.
- Suitable soil material for construction should be available either at or near the construction site.
- The holding pond bywash should not discharge into an adjoining drainage line unless thorough investigation is carried out to demonstrate that the receiving drainage line can safely carry the resulting increased peak flow rates.
- Discharge from the holding pond bywash should be returned to the original drainage line before it leaves the feedlot property.
- The bywash should not directly discharge water to an adjoining landowner's property.
- Holding ponds should not be constructed in areas where seasonal water tables are less than 2 metres below the base of the pond, or in areas where natural groundwater discharges (springs) occur.
- Sufficient area should be allowed between the pen area and holding pond to enable future expansion.
- Holding ponds should comply with relevant national, state and local authority guidelines, codes, and standards.

Properties of materials used

Clay lining material for the holding pond will either be sourced from the site or be brought to the site to ensure sufficient suitable material is available. Suitable clay for lining must conform to the particle size distribution and plasticity limits in Table 1. The clay lining material shall be classified as CL, CI, CH, SC or GC,



Holding pond located outside of the 1-in-100 year floodplain



The siting of this holding pond allows for expansion and its geometry suits the topography of site.



This holding pond was located a sufficient distance away from the closest two rows of production pens to allow for future expansion of the feedlot.

representing clays having low, intermediate and high plasticity, clayey sands and clayey gravels respectively (Table 2). Note that the lining materials used for manure composting and/or stockpiling areas have similar properties.

Table 1. Specifications for clay liner materials

Soil characteristic	Acceptability criterion	Test method
Percentage Fines	More than 25% passing a 75µm sieve More than 15% passing a 2µm sieve	AS 1289.3.6
Liquid Limit	Less than 70	AS 1289.3.1.1
Plasticity Index	More than 15	AS 1289.3.3.1
Emerson Class Number	5 to 6	AS 1289.3.8.1

Table 2. Description, identification and classification of soils (AS 1726-1993)

Group symbol	Major division	Typical names	Particle size	Field identification Sand and Gravels
CL, CI	Silts and clays (liquid limit <50%)	Inorganic clays of low to medium plasticity, gravelly slays, sandy clays, silty clays, lean clays	Fine grained soils	Dry strength –medium to high Dilatancy – none to very slow Toughness – medium
CH	Silts and clays (liquid limit >50%)	Inorganic clays of high plasticity, fat clays		Dry strength – high to very high Dilatancy – none Toughness – high
SC	Sands (more than half of coarse fraction is smaller than 2.36 mm)	Clayey sands, sand-clay mixtures	Fine, 0.075 mm	‘Dirty’ materials with excess of plastic fines, medium to high dry strength
GC	Gravels (more than half of coarse fraction is larger than 2.36 mm)	Clayey gravels, gravel-sand-clay mixture	Fine, 2.36 mm	‘Dirty’ materials with excess of plastic fines, medium to high strength

Sizing

Holding ponds should be large enough to temporarily store wastewater from major storms and/or when extended wet periods prevent irrigation of wastewater. The holding ponds should have sufficient capacity such that pond overflows are limited to an acceptable and approved frequency.

Modelling the volume of effluent held in storage with event-driven inflows and extractions through evaporation from a variable pond surface area and application of wastewater to an utilisation area is a relatively complex task.

Small catchment daily time-step hydrology models may be used in the design of a feedlot holding pond. Provided these models are recognised by regulatory authorities, or sufficient information can be provided on the computations and assumptions, these types of models should generally be acceptable for preparing applications for new developments. For example in Queensland – MEDLI model (Gardner et al 1996), RUSTIC (DPI-DAFF, 1994) and ERIM are small catchment models.

The MEDLI model simultaneously models the daily water balance and crop production in the wastewater utilisation area to determine a sustainable irrigation area and acceptable wet weather holding pond capacity based on nutrient loading.



This holding pond is designed to fit the topography between the feedlot pens and a local drainage line.

The pond capacity in the water balance will have to be adjusted until a pond capacity is determined that notionally spills at the required frequency (one in 10 years or one in 20 years, in the case of an evaporation pond). The meteorological data set used should be representative of the site, and cover a period of at least 100 years (i.e. a data set covering $\geq 36,525$ days). If historical records covering a 100-year period are not available at some sites, interpolated meteorological data can be downloaded through the SILO program.

Typically, small catchment daily time-step hydrology models use the relatively simple (but still robust) United States Department of Agriculture and Soil Conservation Service (USDA SCS) rainfall runoff models (USDA, 2004a and USDA, 2004b) to estimate runoff from the controlled drainage area. In the USDA rainfall runoff model, different values of the catchment index, K1, K2 and K3, are applied to represent respectively dry, normal, or wet soil/manure moisture conditions. Table 3 shows K values typically applicable to feedlot catchments.

Table 3. Suggested values for K1, K2 and K3 in the USDA rainfall runoff model (Source Skerman, 2000)

Catchment	K ₁	K ₂	K ₃
Pens	92	93	95
Hard catchment	96	96	96
Soft catchment	57	75	88

A simple water balance approach may be acceptable as an alternative to the more complex daily time-step hydrology models in some states. In this approach, a simple water budget is based on monthly precipitation and evaporation data.

Modelling based on monthly data is typically more conservative than daily time-step models (Department of Environment and Conservation NSW 2004) and may offer more robustness and flexibility to system operators. Birchall (2008) provides a comprehensive description of a monthly water balance procedure based on the 90th percentile rainfall rather than on mean rainfall.

Design storm methods

Historically, feedlot holding ponds were designed on the basis of a major storm event (e.g. able to contain runoff from a 20-year ARI 24-hour design storm). The 24-hour design storm represents the largest amount of rainfall expected over a 24-hour period. The size of the catchment multiplied by a runoff coefficient and the 20-year, 24-hour storm volume rate is the basis for planning and designing stormwater management facilities (MLA, 2012a).

The intent of this approach was that the designed holding pond should overtop only at a frequency less than one in 10 years (not necessarily only one in 20 years). In practice, however, overtopping events from holding ponds designed on this basis were found to occur at a frequency much greater than an average of one in 10 years (MLA, 2012a).

Overtopping will most likely occur after a prolonged period of wet weather (such as in winter periods in southern areas of Australia) or closely spaced relatively unexceptional rainfall events, as the soils in the effluent utilisation area limit or prevent the application of wastewater.



Well-maintained embankment batters with sufficient freeboard



Large rectangular holding pond



Holding pond shaped to suit the site and topography



Effluent irrigation pumping site on holding pond embankment.



Holding pond with well-grassed batters (to resist erosion) and with sufficient freeboard.

Hence, the design storm method fails to account for the cumulative impact of a series of wet weather events such as might be experienced in a wetter than average season. In most Australian states the design storm approach is no longer considered acceptable and alternative design methods should be adopted (MLA, 2012a).

Alternative methods

State agencies regulating feedlot development may also nominate other acceptable methods such as the Standard tabulated method (Skerman, 2000) which is provided as an option for use in Queensland. However, many of the methods that do not use site-specific daily-step hydrological modelling are better suited to smaller developments. Larger feedlots or those located in sensitive sites will need to undertake more robust modelling approaches.

Freeboard

Freeboard is defined as the vertical height between the crest of a holding pond embankment and the full supply level. Full supply level is the maximum operating level in the holding pond, which is equivalent to the bywash level. When the storage volume increases above this level, the holding pond commences overflowing through the bywash.

Freeboard protects the structural integrity of holding pond embankments from overtopping during bywash overflow events and by wind-induced wave action. Holding ponds that have embankments above the original natural surface level are more susceptible to breaching and failure on overtopping than are below ground holding ponds.

Protection of the internal embankment batters may need to be provided within the freeboard zone to control erosion that may occur even without overtopping. This could be established by good grass vegetation or an engineered solution such as rock rip rap.

Provision of appropriate freeboard can significantly enhance the overall holding pond safety. A minimum freeboard of 0.9 m should be provided between the base of the bywash and the crest of the holding pond embankment.

Overtopping frequency

The *National Guidelines for Beef Cattle Feedlots in Australia - 3rd Edition* (MLA, 2012a) state that overtopping frequency criteria applied to holding ponds are

- for holding ponds from which wastewater is routinely extracted for land application, the spill frequency should not exceed an average of one spill in 10 years.
- for holding ponds from which there is normally no land application (evaporation ponds) the spill frequency should not exceed an average of one spill in 20 years.

In water balance modelling, once a pond has ‘spilled’ the likelihood of another modelled spill occurring with the next few days is quite high. The National Guidelines define one spill as one or more modelled spill events within 30 days of one another.

Allowance for sludge accumulation

When suspended solids from the wastewater settle, a layer of sediment material known as sludge is deposited on the base of the holding pond. The distribution of this sludge is rarely uniform and varies from pond to pond. Sludge should be removed periodically, although weather conditions may delay removal.

Sludge accumulation is known to have an impact on a range of hydraulic processes including short-circuiting, lag time and recirculation which impact on treatment efficiency. Over time the accumulated sludge reduces the effective storage volume of the pond.

With a well designed and maintained sedimentation and holding pond system, sludge accumulation in the holding pond(s) should be minimal. However, an allowance of at least an additional 10% of pond storage capacity should be made to accommodate sludge that may otherwise progressively build up in the pond.

Bywash

Even though holding ponds should overtop only infrequently, a correctly designed bywash is essential. Bywashes are constructed on holding ponds to divert excess water during and following storm events which result in the pond filling to a level above the full supply level (i.e. overtopping events). Holding pond embankments may fail due to inadequate design or construction of the bywash. The bywash must be large enough to handle flood flows without water overtopping the embankment and such flows should not cause erosion of the bywash return slope.

The holding pond should have a bywash capable of discharging the peak flow from the controlled drainage area from a 50-year ARI design storm (National Guidelines for Beef Cattle Feedlots in Australia MLA, 2012a).

There are various configurations of bywash. In a conventional bywash, the floor, known as a spillway, is horizontal (flat). Figure 1 shows a cross section through a typical conventional bywash. Note that the floor of the bywash is level at top water level of the pond.

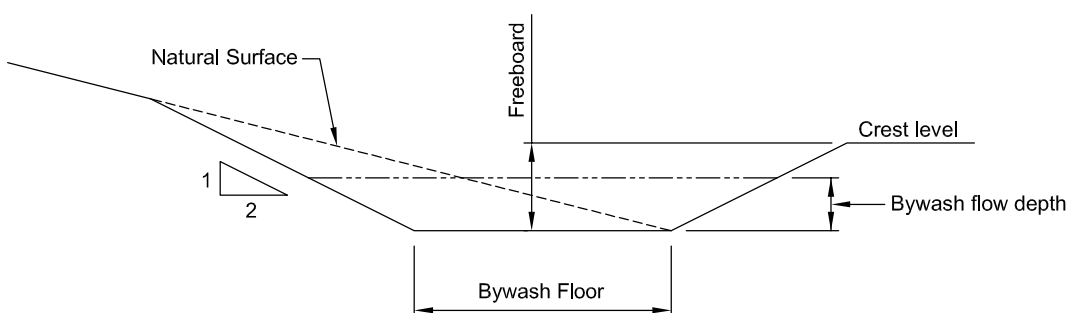

Figure 1. Cross section of a typical bywash

Bywash widths

The bywash inlet width is designed to carry the peak runoff discharge safely around the end of the embankment. The peak runoff discharge (m^3/s) can be calculated using the Rational Method, which is outlined in *Section 10 – Pen and drainage systems*.

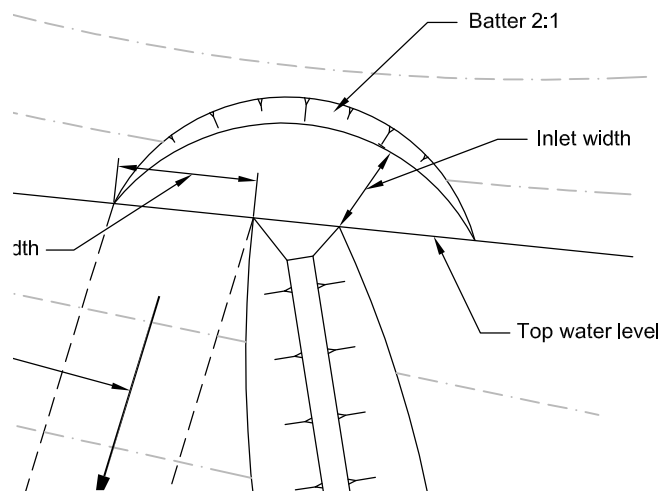

Figure 2. Plan of a typical conventional bywash

The bywash inlet width can be calculated using the broad-crested weir formula. The flow over a broad-crested weir with horizontal crest and 2:1 battered abutments, is given by

$$Q = 1.55LH^{1.5} + 2.47H^{2.5}$$

where

Q = peak runoff discharge (m^3/s)

L = bywash inlet base width (m)

H = depth of flow, or surcharge (m)

Figure 3 illustrates the total depth of water over the bywash at various flow rates and bywash widths for a broad-crested weir.

Typically, bywashes are designed to carry a maximum flow depth of 0.5 m. This provides a flow rate of about $1 \text{ m}^3/\text{s}$ for each 1 m bywash width. The flow velocity should be kept to a maximum value of approximately 1.8 m/s to minimise erosion of the bywash width.

The bywash outlet width should be designed to keep flow velocities on the return slope below 2.5 m/s to minimise the risk of erosion of grass-lined return slopes. As shown in Figure 2, effluent discharged from the bywash flows down the return slope before returning to the original drainage line that carried local runoff prior to the construction of the feedlot.

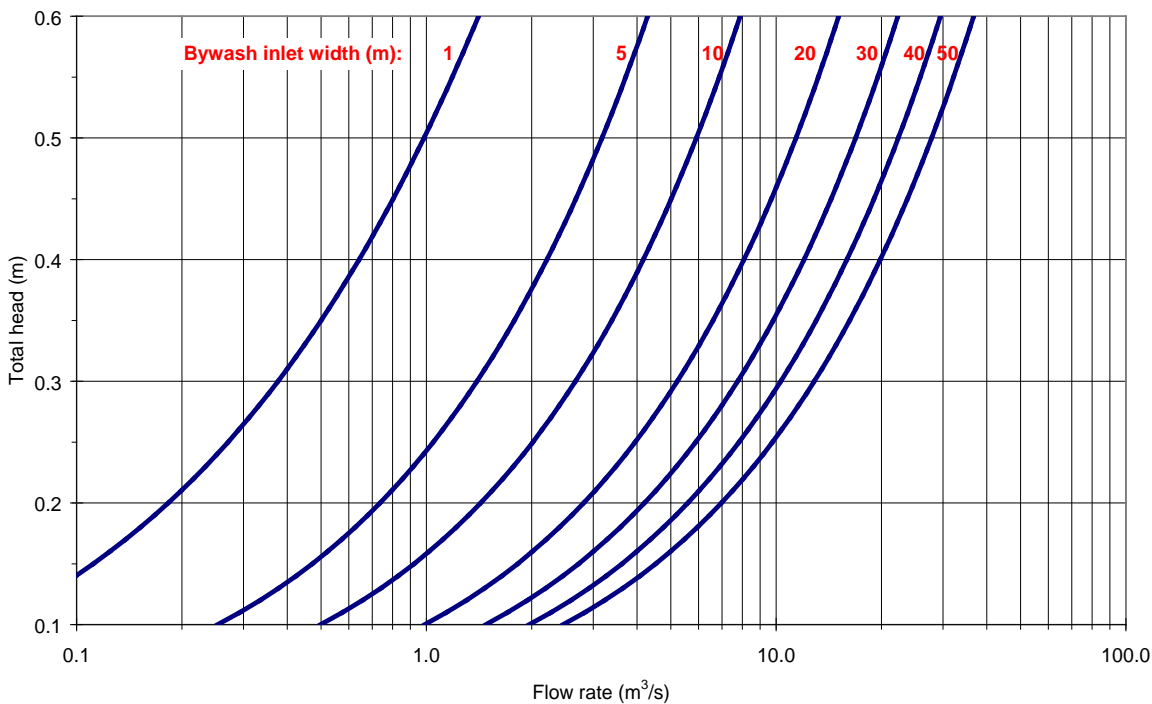

Figure 3. Bywash flow depth for varying flow rates and inlet width (Horton & Jobling, 1992)

Ideally, return slopes should be natural, gently sloping areas supporting a good grass cover in most seasons. The bywash return slope is a critical component of the bywash system and the flattest possible return slope should be adopted.

The location of the return slope should ensure that bywash flows do not erode the external toe of the holding pond embankment.

The bywash outlet width is determined from Figure 4, based on the gradient of the return slope which may be obtained from either contour information or surveyed levels. The bywash inlet width should be at least two thirds the outlet width, to ensure that bywash flows spread uniformly over the outlet reducing the risk of erosion.

A well-grassed bywash return slope should be maintained to prevent erosion. Grass species suited for this purpose include kikuyu, African star grass and para grass.

Alternative designs

Channel bywash

Some holding pond embankment sites have very steep side slopes requiring sizeable excavation to obtain a horizontal spillway floor of the required width. In these situations, a channel bywash may be more suitable. A channel bywash is deeper and narrower than a conventional bywash, although they are difficult to design properly and often require a concrete lip along the outlet width to prevent erosion resulting from the increased flow velocities.

Full concrete bywash

A full concrete bywash is designed and constructed to handle far higher discharge capacities than a grass-lined bywash. However, a full concrete bywash has a higher construction cost than a grass-lined bywash.



A well-grassed embankment will resist erosion.



Lack of vegetative cover and a highly dispersive soil allow wave action to erode this internal batter.

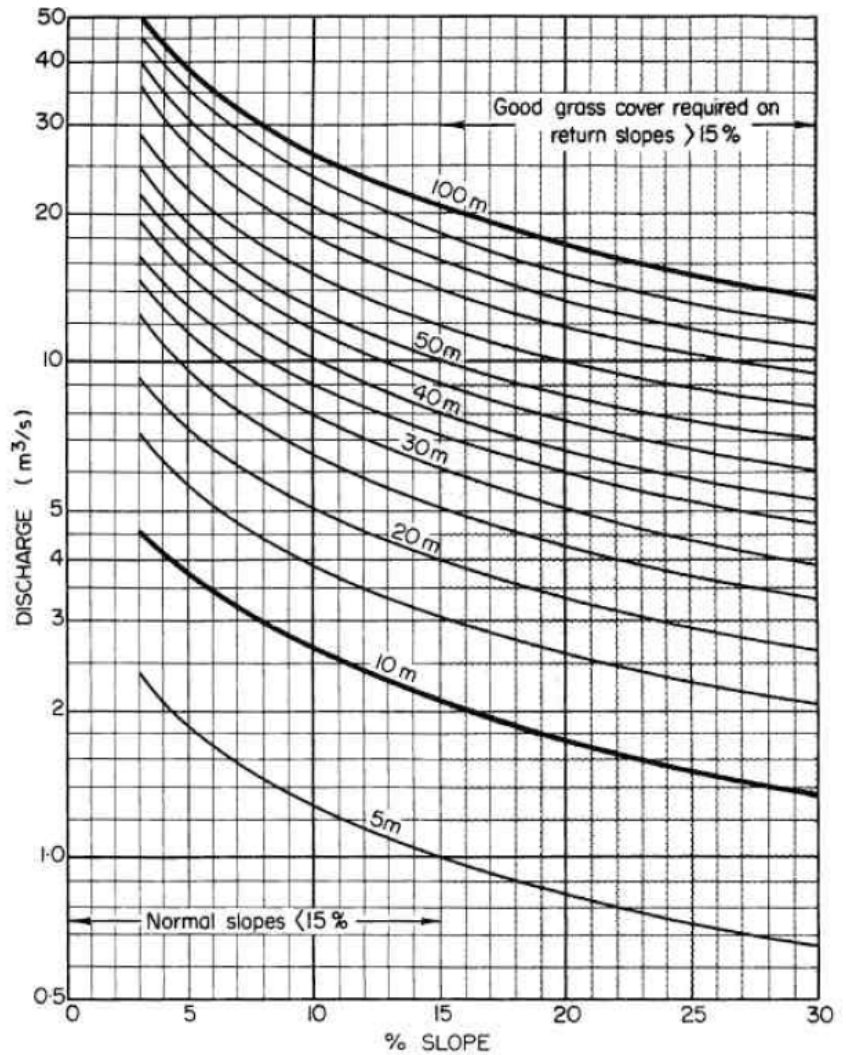

Figure 4. Bywash outlet width for poorly grassed slopes (Horton & Jobling, 1992)

Bywash outlet level

On a flat site, the holding pond storage capacity may be obtained by excavation below ground level. In this situation the bywash outlet will be at the original natural surface, so the entire feedlot drainage system, commencing at the pens, must drain by gravity to this point. If the proposed holding pond bywash site results in excessive earthworks throughout the feedlot system, the designer may need to consider relocating the holding pond if practically possible.

Shape

The topography, site constraints, environmental impacts (e.g. odour), desludging method, lining and wastewater disposal method will influence the holding pond shape.

If the pond is to be lined with HDPE, matching the geometry of the pond to multiples of the roll width of the HDPE liner will minimise liner installation costs.

Efficiency of earthworks can be expressed as the storage to excavation ratio (S:E) i.e. the cubic metres of wastewater stored per cubic metre of earthworks required to create the storage. The S:E

ratio is 1 or less for below ground excavated storages and 2 to 5 for hillside storages, whereas gully dams on flat sites have the best S:E ratios ranging from 5 to over 20.

Most feedlot holding ponds are effectively hillside or below ground storages.

A large surface area in relation to depth will increase the effects of evaporation. A deeper pond will reduce the surface area in relation to depth and reduce the effects of evaporation, but will generally be more expensive to construct.

When deciding on the size and shape of the holding pond, consideration should be given to how the holding pond will be desludged. The pond may be periodically emptied and dried and desludged using mechanical means. The holding pond should be designed to allow access for desludging; in the case of large holding ponds access from a number of locations may be required. If the pond cannot be emptied, desludging can only be achieved using a pump with the outflow going back into the sedimentation system. For HDPE-lined ponds, care must be taken to avoid liner damage if mechanical desludging equipment is used within the holding pond.

Odour

Stable, properly functioning holding ponds do not produce a lot of odour. Producing minimal odour whilst maximising the hydraulic efficiency of the holding pond system is an important design consideration.

The factors which influence holding pond odour emissions include

- climate i.e. frequency and volume of runoff events
- the elapsed time since the last major inflow
- the relative volume of fresh inflow to the volume of effluent already present in the pond and the number of days since the rain event
- pond chemistry in terms of electrical conductivity and/or pond pH
- pond microbiology i.e. populations of microorganisms involved in the breaking down of organic matter
- surface area – a holding pond with less surface area can be an option to minimise odour, however, deeper ponds reduce the potential amount of evaporation.

Additional holding pond capacity may be provided to retain some effluent e.g. a depth of 0.3 m to maintain an active microbiological population. The retained microorganisms can then immediately start breaking down organic material in subsequent inflows. Helping a more rapidly stabilising pond microbiology may reduce the levels and duration of odour emissions.

Pond permeability

The general method of protecting groundwater is to ensure that there is a low-permeability barrier between the stored effluent and any underlying groundwater resources.

The holding pond base and embankment should be underlain by a minimum of either 300 mm clay (or other suitable soil) or by a synthetic liner able to provide a design permeability of $<1 \times 10^{-9}$ m/s (~ 0.1 mm/d).

The installation of piezometers to monitor leakage would be done only if it is a licence requirement. Specialist advice should be sought if leakage detection is to be undertaken.

Clay liner compaction

The density of the clay liner is increased with mechanical compaction to reduce air voids and to fit the clay particles tightly together. This increases the load bearing capacity of the soil, prevents settlement, minimises seasonal movement from moisture changes and prevents leaching.

The effect of compaction can be quantitatively described in terms of increased dry density. Hydraulic conductivity is the key design parameter when evaluating the acceptability of a liner material.

Each layer of clay material shall be compacted to produce a field dry density of at least 95% of the standard maximum laboratory dry density determined in accordance with Method 5.4.1 of AS 1289 (Standards Australia 2007) or a Hilf density ratio of at least 95% when tested in accordance with Methods 5.7.1 of AS 1289 (Standards Australia 2006).

An alternative method of compaction involves rolling each layer of material, placed at the correct moisture content, with at least eight passes of a sheepsfoot roller (described below). As a guide, clay is compacted sufficiently when there is a clearance of 100 mm between the drum of the roller and the compacted material (DAFF 2011).

The specifications of the sheepsfoot roller are

- drum diameter of at least 1 m
- drum length 1.2 times the drum diameter
- the feet should extend approximately 175 mm radially from the drum and be of the taper-foot type, with a cross sectional area close to the outer end of not less than 3200 mm² and not more than 4500 mm²
- the number of feet should be such that their total area close to the outer ends should be 5–8% of the area of the cylinder that would enclose all the feet
- the ballasted weight of the roller should be such that the bearing pressure should not be less than 1750 kPa.



Clay liners should be compacted with at least eight passes of a sheepsfoot roller.

Construction

Construction phase activities include the clearing of vegetation, cut and fill, construction of embankments, drainage and other earthworks. Disturbing the soil surface will increase the potential for erosion and transport of sediment to receiving waters. Earthen embankment slopes and holding pond bywash returns should therefore be stabilised as soon as possible after construction.

Quick tips

- Site and construct holding ponds to protect groundwater, surface water quality, riverine ecosystems and community amenity.
- Undertake daily-step hydrological modelling of the controlled drainage area and holding pond to determine the required capacity of the holding pond having a spill frequency of less than one in 10 years, on average (or one in 20 years, in the case of an evaporation pond).
- One spill is defined as one or more modelled spill events, within 30 days of one another.
- Increase the pond storage capacity by at least 10% to accommodate sludge that will progressively build up.
- The level of the bywash outlet constitutes the starting level from which to grade the drainage system (sedimentation system, drains and pens).
- Effluent discharged from the holding pond bywash should be returned to natural drainage lines before leaving the feedlot property. Effluent should not be discharged directly onto an adjoining landowner's property.

Further reading

Casey, KD, CL Lunney, PJ Watts & RW Tucker 1997, 'Odour emissions from feedlot retention ponds following heavy rainfall', Proceedings of the National Workshop on Odour Measurement Standardization, ed. J. Jiang, University of New South Wales, Sydney, Australia, 20-22 August, pp 157-164.

DPI (now Department of Forestry and Fisheries) 1994, RUSTIC – A Runoff, Storage and Irrigation Model, Manual Version 1.2, DPI Water Resources, Brisbane, Qld. EPA NSW, 2001, Draft Policy – Assessment and Management of Odour from Stationary Sources in NSW, January 2001.

DAFF 2011, Earth pad preparation for deep litter piggeries, solid waste stockpiles and composting areas. DAFF, Brisbane, Queensland.

Gardner, T, Atzeni, M, McGahan, E, Vieritz, A, & Casey, K 1996, 'MEDLI – a computer model to help resolve environmental conflict in intensive rural industries', Presented at Resolving Environmental Conflict, Institution of Engineers, Australia. Brisbane, November 1996.

Guidelines for the establishment and operation of cattle feedlots in South Australia, Department of Primary Industries and Resources (SA) and Environment Protection Authority, 2006, Adelaide.

Guidelines for the Environmental Management of Beef Cattle Feedlots in Western Australia, Bulletin 4550, 2002, WADo Agriculture (ed.), Western Australia Department of Agriculture, Perth, WA.

Horton A.J. and Jobling, G.A. ed 1992, Farm water supplies design manual / Farm Water Supplies Section, Irrigation Branch, Queensland Water Resources Commission; edited by A.J. Horton and G.A. Jobling. Water Resources Commission. Brisbane, Queensland.

Lott, SC, 1998, *Feedlot Hydrology*, PhD thesis, University of Southern Queensland, Australia.

MLA, 2012a, *National Guidelines for Beef Cattle Feedlots in Australia - 3rd Edition*, Feedlot Industry Accreditation Committee (ed.), June 2012, Meat & Livestock Australia, Sydney, NSW.

MLA, 2012b, *National Beef Cattle Feedlot Environmental Code of Practice - 2nd Edition*, Feedlot Industry Accreditation Committee (ed.), June 2012, Meat & Livestock Australia, Sydney, NSW.

Nelson, K.D. 1985, *Design and Construction of Small Earth Dams*, Inkata Press Pty Ltd, Melbourne.

Skerman, AG, 2000, Reference Manual for the Establishment and Operation of Beef Cattle Feedlots in Queensland, Publication coordinated by the Qld Cattle Feedlot Advisory Committee (FLAC), Department of Primary Industries (DPI), Information Series QI99070

The New South Wales feedlot manual, 1997, NSW Agriculture, NSW Agriculture, Department of Land and Water Conservation, Department of Urban Affairs and Planning & Environment Protection Authority, Orange.

SIL0 climate data – www.longpaddock.qld.gov.au/silo/

Victorian code for cattle feedlots, August 1995, Victorian Feedlot Committee, Department of Agriculture, Energy & Minerals, Melbourne.

Watts, PJ (1999). Development of a pig effluent emissions database and analysis of promising control strategies. Final report Part A - Database on odour research and emission rates. Prepared for APL. FSA Environmental: Toowoomba, Queensland.

Watts, PJ, Jones, M., Lott, SC, Tucker, RW and Smith, RJ (1994) Feedlot odor emissions following heavy rainfall. *Transactions of the American Society of Agricultural Engineers* 37(2), 629-636.

USDA-SCS 1972, *National Engineering Handbook, Section 4 - Hydrology*, US Department of Agriculture, Washington D.C. USDA, 2004a, Estimation of direct runoff from storm rainfall, in 'Chapter 10 National Engineering Handbook - Part 630', United States Department of Agriculture National Resources Conservation Service, Washington, DC.

USDA, 2004b, Hydrologic soil-cover complexes, in 'Chapter 9 National Engineering Handbook - Part 630', United States Department of Agriculture National Resources Conservation Service, Washington, DC.



FEEDLOT DESIGN AND CONSTRUCTION

13. Access and internal road systems

AUTHORS: Rod Davis and Ross Stafford

Introduction

Access to the site and the layout of internal road systems are critical to the efficient and safe functioning of the feedlot.

Access to the site includes the overall layout, infrastructure and facilities at the access point. These may include traffic access from the local road network and the proper level of access control for all personnel, visitors and traffic to the site. Design of traffic access requirements from the road network is usually governed by local government or state authority requirements.

Access control is to secure the site from unauthorised access while optimising authorised vehicular traffic flow. Each feedlot site will have its own set of challenges and security solutions.

The layout of the on site or internal road system has to take into account the mix of vehicles – semi-trailers, road trains, feed trucks, maintenance and other operational vehicles together with tractors and front end loaders – that can all be operating on the internal road network.



Slip lanes may be required on turn-ins from major roads.

Design objectives

The design objectives for feedlot access and the internal road system are to

- provide efficient, functional and safe access to the site
- provide an appropriate level of access control to the site for personnel, visitors and traffic for security and biosecurity purposes
- have an internal road system that is functional and safe in all weather conditions
- have a fit-for-purpose internal road system, with adequate road width, turning radii, drainage, good running surface and no blind corners
- provide adequate sight distance through intersections, curves and crests
- provide good traffic flow around the site with little or no need for vehicles to reverse
- restrict interference between feedlot operating vehicles and irregular delivery vehicles
- reduce the likelihood of incidents or collisions on the site.

Mandatory requirements

Compliance with:

- *National Guidelines for Beef Cattle Feedlots in Australia (MLA, 2012a).*
- *National Beef Cattle Feedlot Environmental Code of Practice (MLA, 2012b).*
- relevant Commonwealth, state and local authority codes, regulations and relevant Australian standards as applicable to the feedlot development.
- National Biosecurity manual for Beef Cattle Feedlots (Animal Health Australia, 2013).

Design choices

Intersection with local road network

Local and state governments generally have criteria by which they judge the significance of the impact of feedlot traffic on the road network. Typically these will involve a threshold increase in road traffic volumes or pavement loads.

Feedlots are sited in rural locations and most likely serviced by rural roads. As feedlots require frequent access by vehicles with high axle loads, upgrades to the local road network are often imposed on feedlot developments. Common requirements include the need for all-weather access, contribution to local authority for road maintenance/upgrades (pavement, culverts, bridges), preferred access routes to the site and upgraded intersections servicing the feedlot to a standardised design. Higher traffic volumes may trigger the need to install a slip or turning lane and/or acceleration and deceleration lanes to cater for the additional truck movements. Figure 1 illustrates typical intersection layout for a road-train configuration.



Turn-in and turn-out onto major road

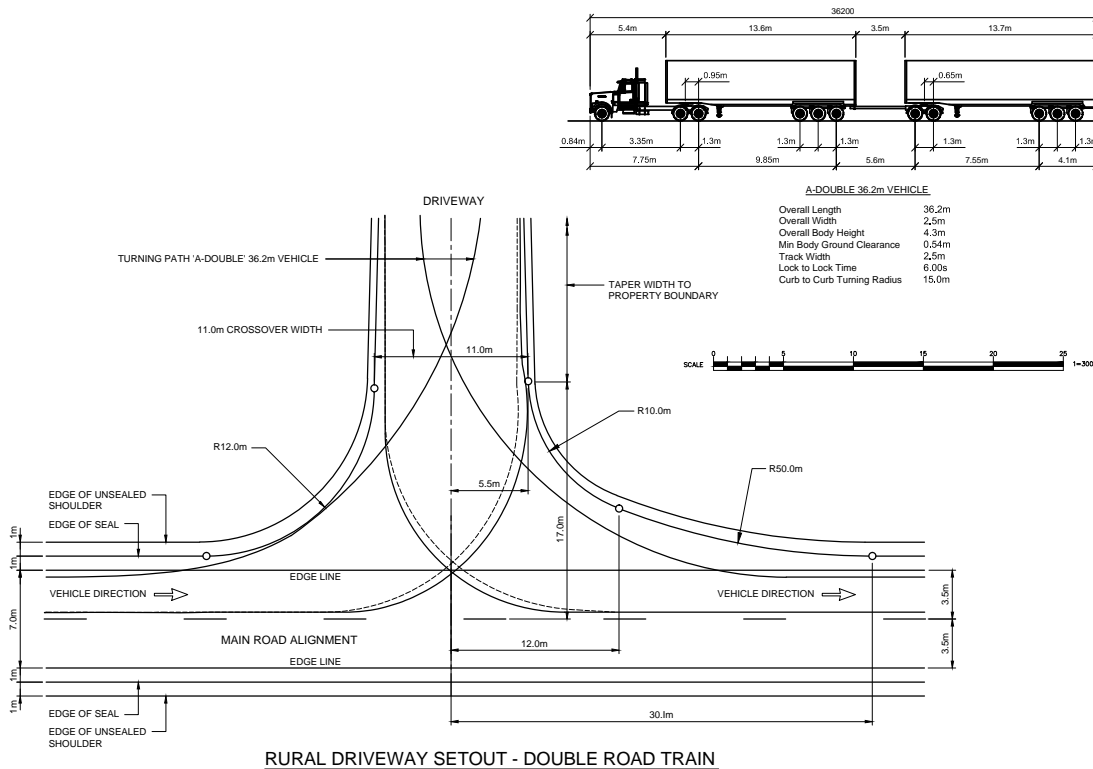

Figure 1. Typical intersection setout for road trains

Because of low ambient noise levels in rural areas (particularly at night) traffic noise may require noise-related conditions, such as curfews on traffic movements or having designated access routes.

Proponents should consult with the responsible authority early in the feedlot planning stages to identify any impacts that the development may have on the local road network and what conditions are likely to be imposed on the development.



Security gate at entrance to large feedlot



Boom gate access control and signage at feedlot entrance



Signs at a feedlot entrance advise entry requirements to the site.

Access control

The term access control generally refers to physical or behavioural measures for managing the passage of personnel and vehicles into, out of and within a feedlot complex. Access control for security and biosecurity purposes should be sufficient to protect the feedlot while still allowing effective access for onsite traffic.

Access control at feedlots typically consists of physical control processes. Passive barriers can secure a site perimeter to limit unwanted access. Access to various buildings (e.g. control rooms, chemical storage) may need to be controlled.

The following measures may be used to control access into, within, and out of a given site, area or building

- Physical barriers
 - fencing
 - boom gate
 - lockable gates and grids
 - surveillance video/still cameras.
- Signage
 - posting ‘Private Property’, ‘No Trespassing’ and ‘Authorised Access Only’ signs
 - posting sign ‘All visitors to this site must report to the office’
 - property sign and contact details e.g. office phone number, UHF channel
 - posting signs indicating biosecurity levels in effect on the site. Placing ‘Restricted entry’ notices on the access points to relevant areas.
- Require all visitors to sign a visitor log and complete a biosecurity assessment form before being escorted to approved areas of operations.
- Establish a system for determining which vehicles may enter the site, which gates or other entrances they may use and under what conditions.
- Designate a parking area for vehicles entering the site, away from traffic areas used by feed trucks, mobile plant and machinery and commodity and livestock delivery vehicles.
- Provide facilities outside the secure perimeter of the feedlot for incoming livestock vehicles to be safely unloaded and the cattle given access to water and feed should they arrive outside normal operating hours.

Further detail on these biosecurity requirements can be found in *Feedlot Biosecurity – Understanding and Implementing the NFAS Guidelines* (ALFA, 2013) and/or the *National Biosecurity Manual for Beef Cattle Feedlots* (Animal Health Australia, 2013).

Internal road system

The internal road system should be considered in the overall site layout design process (see *Section 2 – Site layout*). The objective of the road network is to have a functional grouping of roads to ensure practical, efficient, user-friendly and safe movement around the site.

The following elements should be considered when designing the internal road system.

Traffic routes

The location of feedlot processes will influence the extent and direction of internal traffic. Careful planning and consideration of site traffic routes can result in production efficiencies and a reduction in the likelihood of collisions between vehicles and/or equipment (see *Section 2 – Site layout*). Measures that can be considered to manage traffic flow around the site include

- good sight lines and separation of heavy and light vehicles.
- types of road traffic, typically commodity and livestock delivery vehicles (such as semi-trailers, B-doubles, road trains), internal vehicles (including light vehicles, feed trucks, tractors) and visitor and employee vehicles
- one-way systems reduce the likelihood of collision, reduce congestion and improve traffic movement
- ability to reverse traffic flow dependent of operational/ climatic conditions e.g. dust generation during unloading of commodities
- roundabouts may avoid traffic turning directly in front of oncoming traffic at intersections
- avoid curves and crests for locations of intersections
- minimise 4-way intersections and avoid Y intersections where possible
- provide queuing areas for incoming trucks so as not interfere with moving road traffic during any periods of high volume movement
- provide sufficient area for laydown/parking of heavy vehicles
- provide a light vehicle park area for employees and visitors to the feedlot.

Swept path for turns

When a heavy vehicle turns, the rear of the vehicle covers a wider path towards the inside of the turn than the path of the prime mover. The swept path envelope is the road area covered by the outermost and innermost points of the vehicle during the turn.

Swept path information for the range of vehicles to be operating at the feedlot is needed to provide appropriate and safe access to the various facilities around the feedlot. Semi-trailers and B-doubles are the most common vehicles. Figure 2 illustrates the swept paths for a B-double vehicle at various turning angles.

At a feedlot, sufficient room is needed for feed trucks to turn around at the end of one row of feed bunks and then straighten up before starting to feed the next row. Room may be needed for side loading or end loading of livestock vehicles. Figures 3 and 4 illustrate the turning area required for a typical feed truck at the end of a feed road to turn around and straighten to deliver feed to the bunk. Turning circles should be as large as practical with a minimum radius of about 10 m; the tighter the turning radius the greater the damage to the road surface and scrubbing of vehicle tyres.



Turn-in and turn-out from feedlot access road onto minor rural road – sufficient area is provided for vehicle turning.

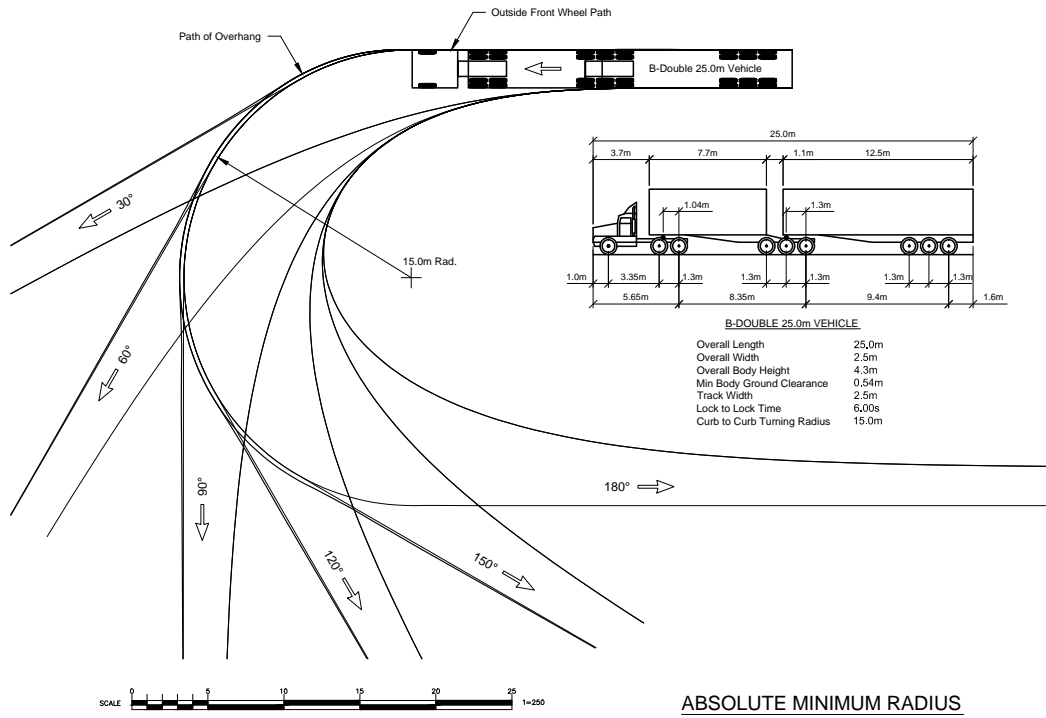
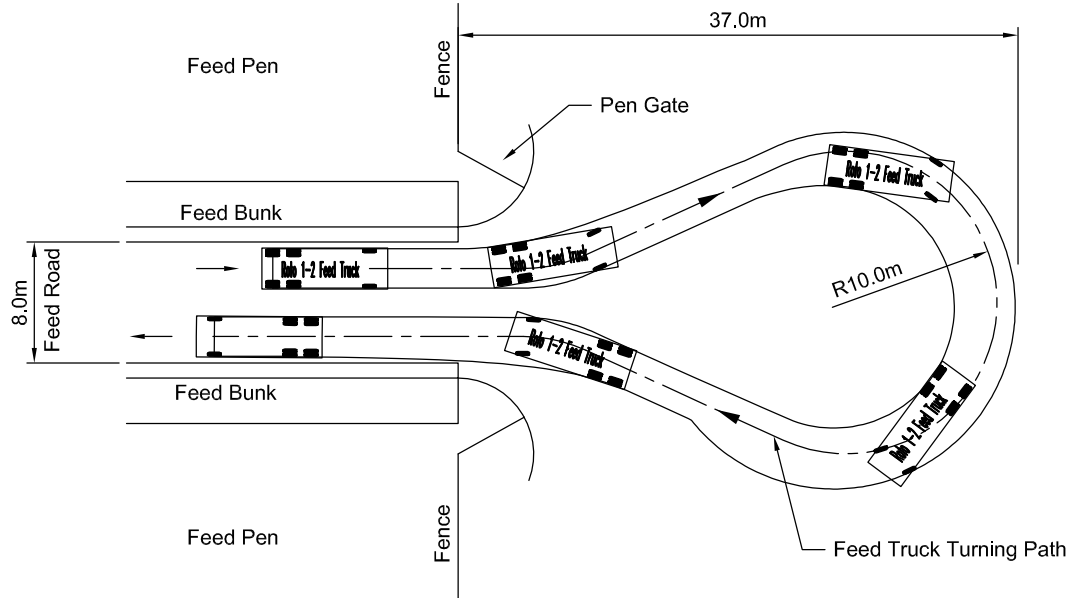

Figure 2. Swept path for B-double truck

Figure 3. Swept path for typical feed truck in a back to back pen layout



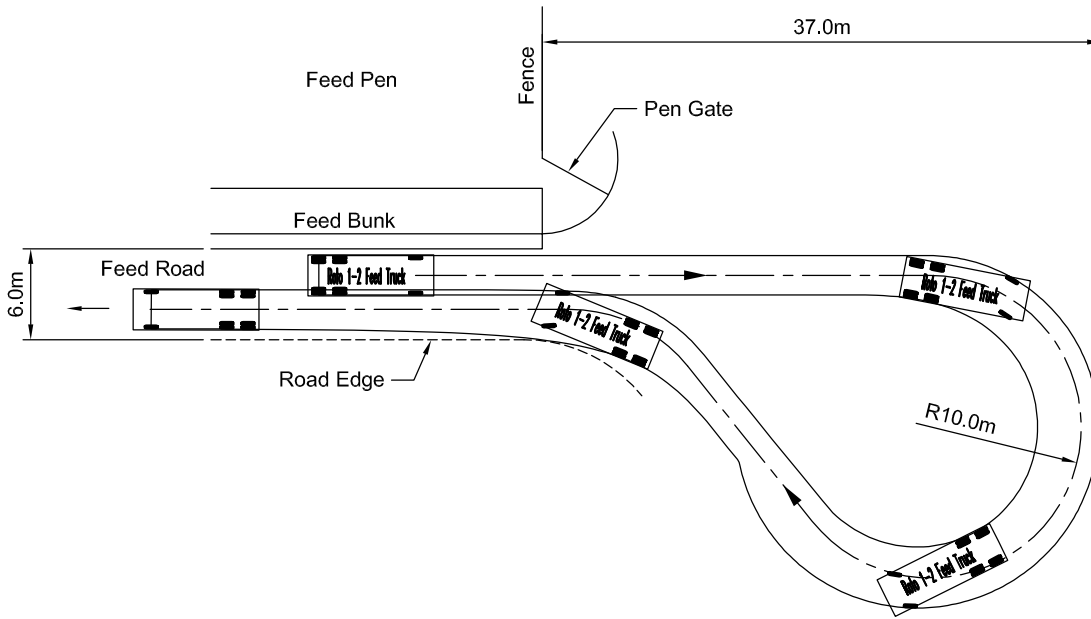

Figure 4. Swept path for typical feed truck in a sawtooth pen layout

Width

Internal roads should generally be designed to be about 3.5 times the width of the largest vehicle to allow vehicles to pass safely. Hence, road widths of about eight metres are typical although a width of four metres would be appropriate for one-way roads. The typical cross sections of on site feedlot unsealed and sealed roads are illustrated in Figures 5 and 6 respectively. Note the variation in crossfall for drainage between the unsealed and sealed cross sections.



Internal roads should be wide enough to allow vehicles to pass safely.

Figure 5. Typical sealed road cross section

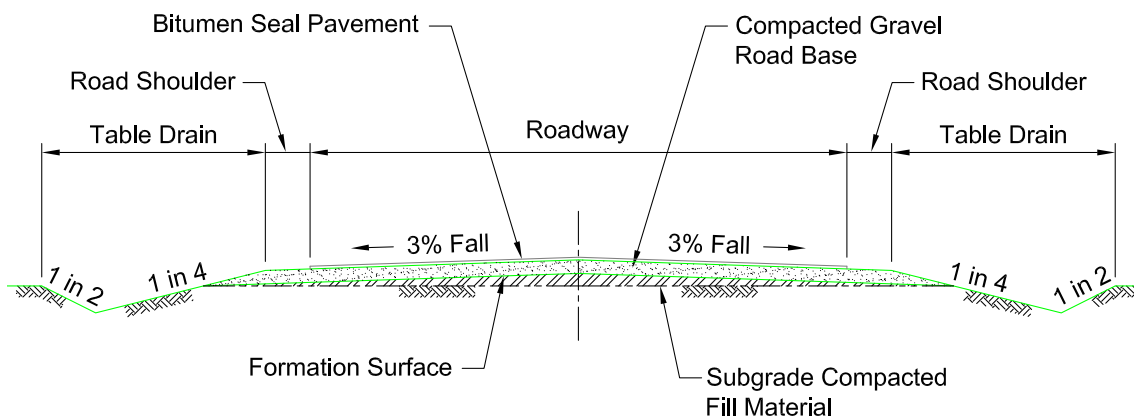

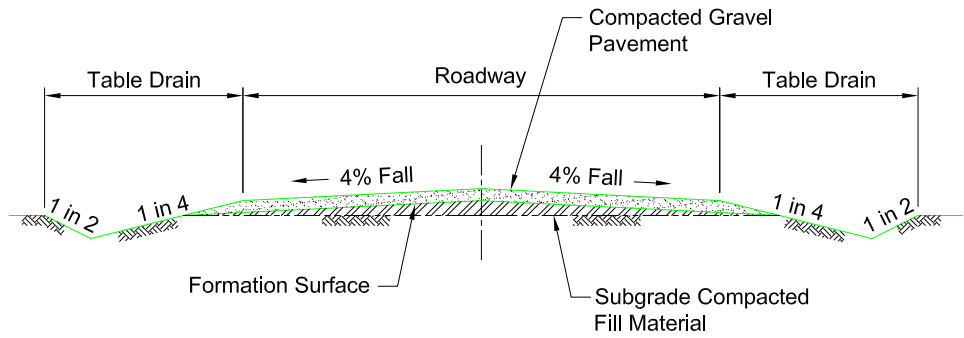

Figure 6. Typical unsealed road cross section

Vehicles using the road system

The interaction of heavy and light vehicles on the internal road system may increase the likelihood of incidents. Where possible separate roads should be provided for light vehicles.

Safety

Signage and delineation should be provided to guide drivers. Intersections should be signed in advance with warning signs and directional signs; speed limits should be set and managed in accordance with the road hierarchy and function.

Crossfall and camber

Poor crossfall or camber may result in the buildup of loose material on the outside of a road curve, creating a potential safety hazard. Good camber will assist driver comfort and safety in travelling around curves, and will minimise the buildup of loose material.

Drainage

Without good drainage, roads will start to degrade quickly. Where possible, table or V drains should be constructed to remove the run-off water from the edge of the road. See Section 17 – Pen and road surfaces.

Intersections

Traffic entering most intersections is allowed to cross, enter on to, or exit from one direction into any other, and this increases the risk of conflicts unless the design of intersections is kept simple. A simple T-intersection has half the crossing conflict points (3) when compared to a 4-way intersection (16) as shown in Figure 7. Y-intersections are not desirable as they allow for high speed movement through intersections with limited visibility. Y-intersections should be realigned into T-intersections as shown in Figure 8.



Signage illustrating the site layout and traffic flow and other site entry requirements helps new drivers.



Staggered T-intersections have fewer conflict points than 4-way intersections.

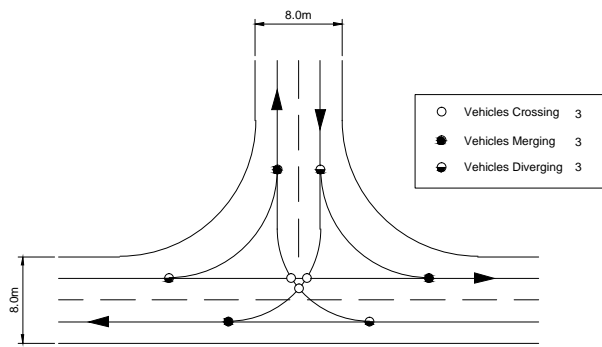
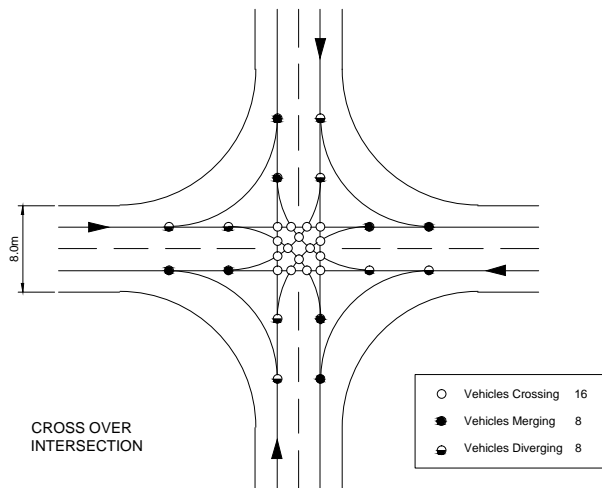
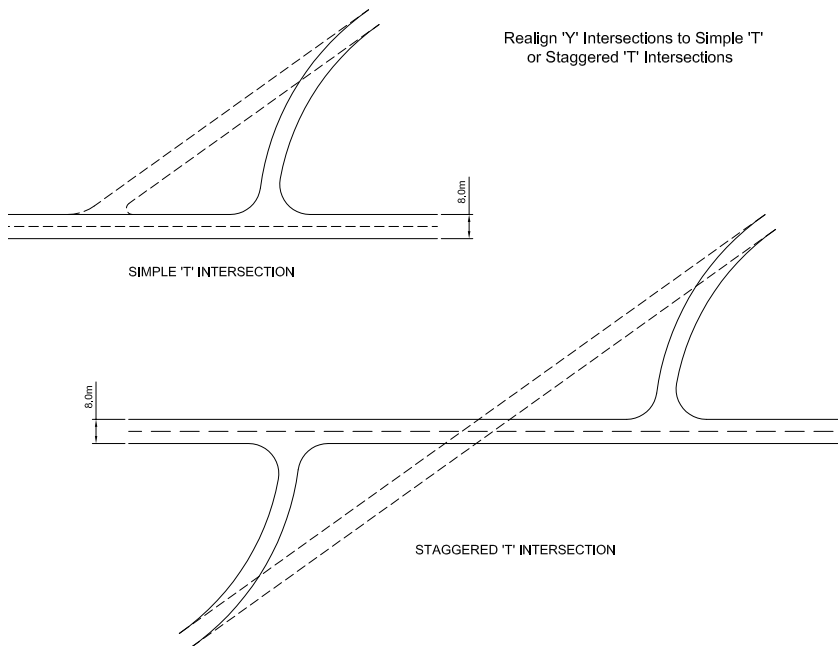

Figure 7. Conflict points of T- and 4-way intersections

Figure 8. Realignment of Y-intersections to eliminate conflict points



Intersection location

Road intersections on curves and crests should be avoided as these can restrict visibility for drivers entering the through road as shown in Figure 9. Vegetation e.g. shrubbery should not be planted at an intersection or should be lowered to avoid masking of light vehicles. A separation island in the side road avoids the cutting of the corners through the intersection.

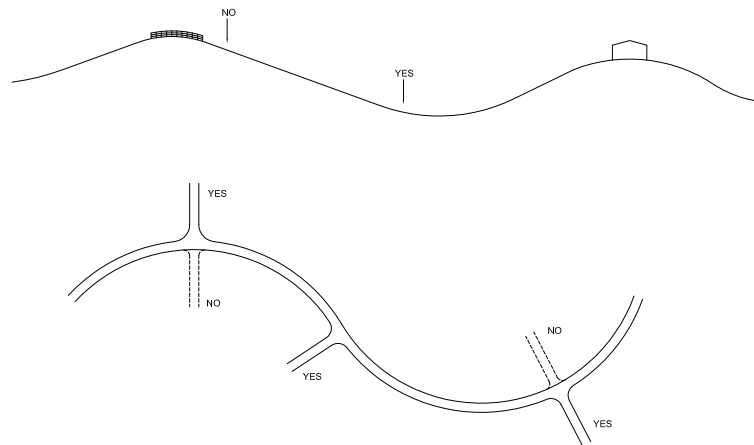

Figure 9. Location of intersection on crests and curves

Number of intersections

As a feedlot expands, new roads may need to be built to gain access to various locations on the site; this may increase the number of intersections, increasing the risk of incidents. Consider closing off roads with clearly visible earth bunds if they are not required operationally.

Other factors

Factors such as the road width, swept path, pitch, gradient and camber of roads affect vehicle stability, road damage and traffic flow. Other factors include fitting the road to the natural contours of the land, number of lanes, sight distance, livestock and feed truck turnarounds and the practicalities of feedlot access and safety.

Sight distance is important at critical locations such as at tight curves and intersections. Sight distance is influenced by road geometry and obstructions on the roadside e.g. vegetation, fences, buildings. Safe stopping sight distances for unsealed roads are longer than those for sealed roads.

Speed limits

Speed limits are necessary for safety near buildings and high foot traffic areas and to minimise dust generation, but they should be realistic and consistent without too many variations. As a guide, usually two or three different speed limits are sufficient. Limits could be 20 km/h for pedestrian areas and narrow roads, but higher where dust is not a problem and where there are few vehicles going in different directions.



Signage at the feedlot entrance to advise of the security and entry requirements and vehicle speed limit on the site.

Signage

Road signs are low cost items and should be used appropriately to warn motorists of potential hazards. All signage on site should conform to the relevant Australian Standard (AS1742) to create a consistent road environment that informs the driver. Signs should be the correct size and reflective without having multiple signs that convey the same message. Intersection signage should be consistent in its application, ‘Stop’ or ‘Give way’ signs installed at all intersections, ‘Keep left’ signs installed on earth berms, information signs installed where required, and warning signs installed at the correct locations.

Delineation

Delineators in the form of guideposts may be installed on roads. Guideposts should be spaced consistently with red reflectors on the left hand side and white reflectors on the right hand side.

Road surfacing

The design and construction of road surfaces are important for their long-term performance. One of the fundamental ingredients for a successful road surface is a strong and stable underlying subgrade. Any surface will have reduced life if the subgrade or the surface sub-layers are weak through inadequate design, poor quality materials, poor construction techniques or poor maintenance practices.

Typically, road surfaces are unbound natural material such as gravel with or without surface sealing. *Section 17 – Pen and road surfaces* provides information on road surfacing.

Typical truck dimensions

Typical dimensions of semi-trailer, B-double and road train are shown in Figures 10, 11 and 12 respectively.

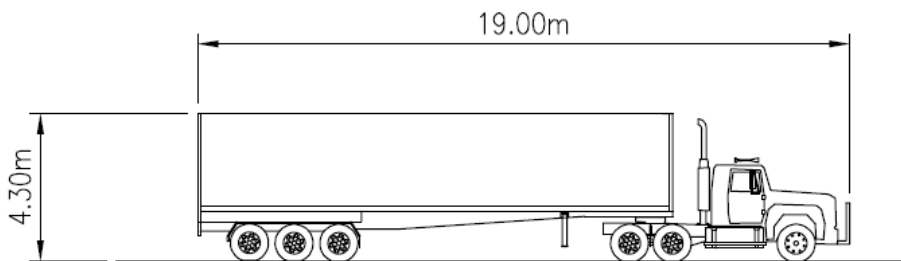

Single Articulated	19.0m
Overall Length	19.00m
Overall Width	2.50m
Overall Body Height	4.30m
Min Body Ground Clearance	0.54m
Track Width	2.50m
Curb to Curb Turning Radius	12.50m

Figure 10. Dimensions of 19 m semi-trailer



Concrete pavement on feedlot access road to prevent road damage caused by heavy vehicle traffic at turn-in and turn-out



Unsealed road with a well-maintained and shaped crown, shoulder and v-drains

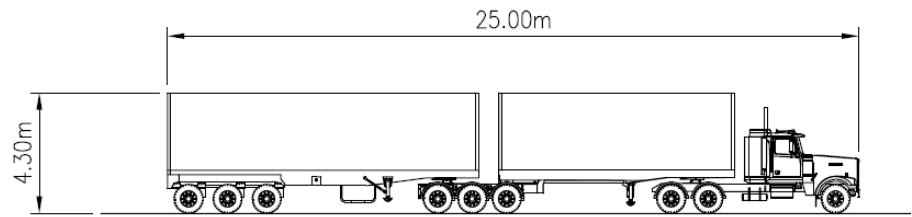

B-Double 25.0m	
Overall Length	25.00m
Overall Width	2.50m
Overall Body Height	4.30m
Min Body Ground Clearance	0.54m
Track Width	2.50m
Curb to Curb Turning Radius	15.00m

Figure 11. Dimensions of 25 m B-double

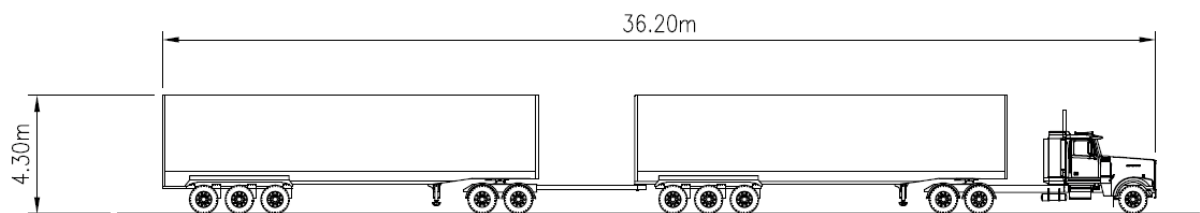

A-Double 36.2m	
Overall Length	36.20m
Overall Width	2.50m
Overall Body Height	4.30m
Min Body Ground Clearance	0.54m
Track Width	2.50m
Curb to Curb Turning Radius	15.00m

Figure 12. Dimensions of 36 m A-double (Road train)

Quick tips

- Consult with the responsible authority early in the feedlot planning stages to identify any impacts that the development may have on the local road network.
- Access control is critical for security and biosecurity purposes. Establish a system that determines which vehicles may enter the site, which entrances they may use and under what conditions.
- Consider the internal road system and traffic flow in the overall site layout during the design process.
- Vehicles of various sizes and configurations enter feedlots. This may include heavy vehicles such as semi-trailers, B-doubles and road trains, medium rigid vehicles such as feed trucks, tractors and light vehicles.
- Minimise the number of 4-way intersections and avoid Y-intersections to reduce the likelihood of collisions.
- The on site road network should have adequate road width, turning radii and good running surfaces for the vehicles expected.
- Avoid road intersections on curves and crests as these restrict visibility for drivers.
- Avoid planting trees or shrubbery at an intersection as these can mask light vehicles.

Further reading

- ALFA, 2013, Feedlot Biosecurity – Understanding and Implementing the NFAS Guidelines, ALFA, Sydney.
- Animal Health Australia, 2013, National Biosecurity Manual for Beef Cattle Feedlots, Animal Health Australia.
- AUS-MEAT, 2013, The National Feedlot Accreditation Scheme.
www.ausmeat.com.au
- Austroads, 2006, Guide to Road Design Part 2: Design Considerations, Publication No AGRD02-06.
- Austroads, 2010, Guide to Road Design Part 3: Geometric Design, Publication No AGRD03-10.
- Austroads, 2009, Guide to Road Design Part 4: Intersections and Crossings – General Publication No AGRD04-09.
- Austroads, 2010, Guide to Road Design Part 6: Roadside Design, Safety and Barriers Publication No AGRD06-09.
- Austroads, 2010, Guide to Road Design Part 7: Geotechnical Investigation and Design Publication No AGRD07-08.
- MLA, 2012, National Guidelines for Beef Cattle Feedlots in Australia - 3rd Edition, Feedlot Industry Accreditation Committee (ed.), June 2012, Meat & Livestock Australia, Sydney, NSW.
- MLA, 2012, National Beef Cattle Feedlot Environmental Code of Practice – 2nd Edition, Feedlot Industry Accreditation Committee (ed.), June 2012, Meat & Livestock Australia, Sydney, NSW.
- Standards Australia, AS1742.1-2003 - Manual of uniform traffic control devices - General introduction and index of signs.
- Standards Australia, AS1742.2-2009 - Manual of uniform traffic control devices - Traffic control devices for general use.
- Standards Australia, AS1742.3-2009 - Manual of uniform traffic control devices - Traffic control devices for works on roads.
- Standards Australia, AS1742.4-2008 - Manual of uniform traffic control devices - Speed controls
- Standards Australia, AS1742.3-2009 - Manual of uniform traffic control devices - Traffic control devices for works on roads.
- Standards Australia, AS1742.14-1996 - Manual of uniform traffic control devices - Traffic signals.

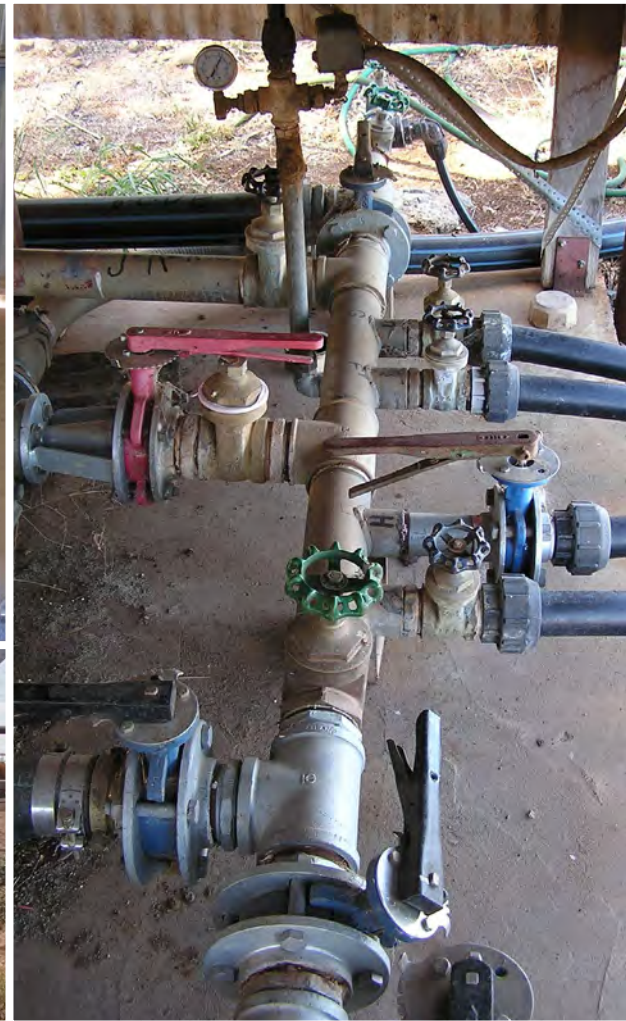

FEEDLOT DESIGN AND CONSTRUCTION

14. Water reticulation system

AUTHOR: Rod Davis

Introduction

An adequate supply of water is required for cattle to drink, in feed preparation and for sundry other uses.

Planning and designing a feedlot water reticulation system for each feedlot depends on its access to water, location, site, size and operation.

The basic principles in the design of a water reticulation system are reliability, redundancy, utility and economy. Utility can be defined as a reliable, easy to operate, trouble-free system that delivers water in the quantity and at the points required, with no more attention than routine maintenance. Economy can be defined as a system installed at a minimum expense, without sacrificing utility that will operate for its design life without ongoing capital expenditure or excessive maintenance costs.

Design objectives

The water reticulation system should

- ensure the layout, pipe size and pump capacity of the system can efficiently supply the feedlot with water
- be sized to supply water throughout the feedlot during peak demand periods
- incorporate a storage system to cater for fluctuations in supply and demand and to act as an emergency supply in the event water supply failure
- allow easy maintenance to pipes, valves and pumps
- allow maintenance on some parts of the system while maintaining a continuous water supply to all areas of the feedlot
- be protected from damage by cattle and machinery
- supply fresh, cool, clean palatable and high quality drinking water to the cattle.

Mandatory requirements

Compliance with

- Australian Animal Standards and Guidelines for Cattle (DAFF, 2013).
- National Guidelines for Beef Cattle Feedlots in Australia (MLA, 2012a). These state that a feedlot requires a secure water supply, that security must be in both a legal (i.e. a legal right to the required volume) and a physical sense (i.e. the physical ability to pump, store, and deliver the required volume of water).
- National Beef Cattle Feedlot Environmental Code of Practice (MLA, 2012b). Performance measure 1.5.2 states that a feedlot has a water supply able to sustain the operations of the feedlot under normal conditions.
- National Feedlot Accreditation Scheme (AUS-MEAT, 2013).

Technical requirements

Factors to be considered when planning and designing a water reticulation system include

Volume of water required

Water is needed for cattle drinking, feed processing, cleaning (including yards, machinery and cattle washing) and other general operations around the feedlot.

Section 4 – Water requirements provides information on the water requirements at Australian feedlots.

Distance

Moving water takes energy to overcome pipe resistance and changes in ground elevation. The distance between water sources, temporary supply and delivery point will affect capital expenditure and operational costs.

Design flow rate and pressure

A reticulation system must be sized to supply water at sufficient pressure throughout the feedlot during peak demand periods.

Peak water demand can be estimated by understanding the diurnal pattern of intake and by studying historical climate records. See *Section 4* for calculation of peak demand.

Water reticulation system

Designing a feedlot water reticulation system can be complex. Professional assistance from a suitability qualified and experienced water engineer or a company specialising in water supply and reticulation systems should be obtained to determine system layout, pumping capacity and pressure, pipeline sizes and valve locations. The designer should locate air relief valves, vacuum relief valves, isolation valves, water storage and thrust blocks as well as pipeline and fittings.

Water reticulation systems can be either gravity flow or pressurised or a combination of both. Gravity flow avoids any potential equipment failure in a pumped system.

Gravity flow

In a gravity pipeline system, the water storage is higher than all points in the delivery pipeline and no pump is required downstream of the storage. For example, the water supply may be located at the highest point at the site and at the end of a pumped pipeline. This is the preferred type of system for cattle drinking water supply as it has less reliance on infrastructure (e.g. electrical power, pumps).

A gravity system is usually characterised by being installed on a positive grade in the direction of flow for its entire length. Air locks at significant high points in the pipeline are prevented by installing air valves or stand pipe vents. Air valves will not work if pressure is too low.



Water storage at a higher elevation than the feedlot allows gravity flow of water.



A turkey nest storage situated high above the feedlot allows gravity flow of water around the site.



Gravity flow available from elevated placement of water storage.

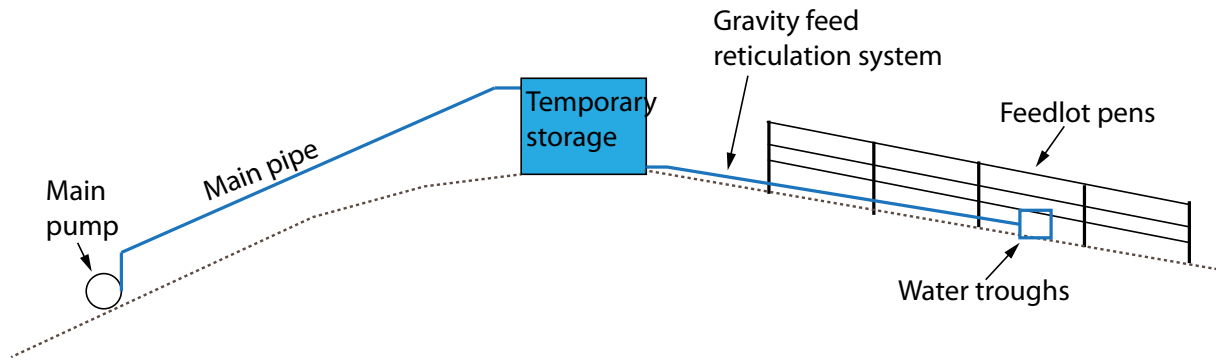

Figure 1 Components of a water reticulation system

Pressurised system

Pumps are commonly used to lift water from a bore or water stream (creek, river) to a water storage at a higher elevation, or to pressurise the water system to deliver it through a pipeline around the feedlot.

The design considerations in a pressurised system include pump type (centrifugal, turbine and positive displacement), pump capacity (single, multi-pump, distance and volume of water to be transferred) and pump control (automatic pressure, timed, manual).

Pipeline network

The delivery pipeline is sized to carry the amount of water required by the length of line, the difference in elevation and water demand at each outlet. Pipeline sizes and features must be planned for each specific system based on the site and system requirements.

Types of distribution networks

Branched network

This network is similar to the branching of a tree. It consists of

- main (trunk) line
- sub-mains
- branches.

The mainline is the main source of water supply. There is no water distribution to watering points from the mainline. Sub-mains are connected to the main line and are usually located along the main service or feed delivery roads. Branches are connected to the sub-mains and the watering points are located on the branches (Figure 2).

Advantages

- simple method of water distribution
- simplified delivery calculations
- economical dimensions of the pipes
- fewer cut-off valves.



Pumped reticulation system with a standby pump and associated controllers and valving



A pumped reticulation system manifold with various take-offs and shut-off valves for flow control

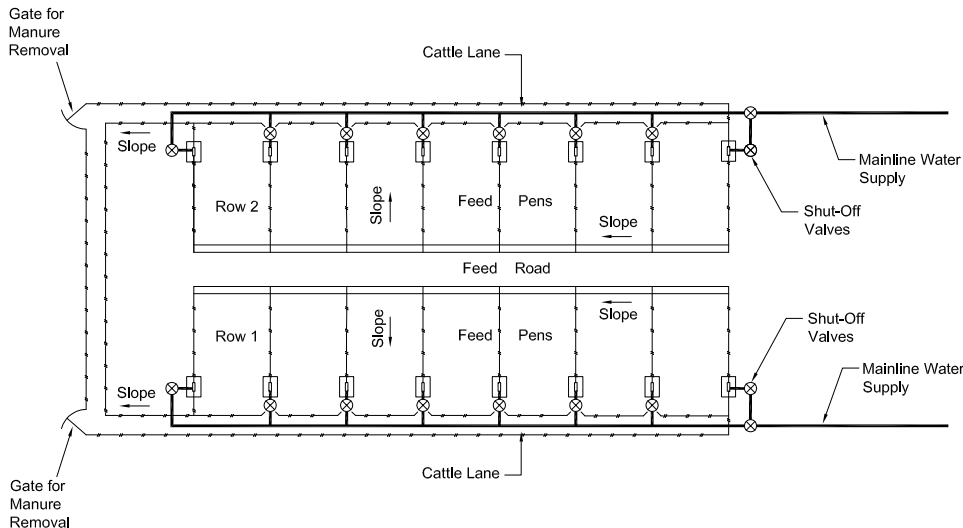

Figure 2. Branched water reticulation network

Disadvantages

- The area or zone receiving water from a pipe that is broken is without water until the repair is completed. This can be a major issue when supplying drinking water to cattle.
- There are many dead ends where water does not circulate but remains static.
- Sediments can accumulate in the dead end with potential bacterial growth. Drain valves at dead ends allow stagnant water to be drained out periodically, wasting a significant amount of water.
- If the feedlot undergoes expansion, the pressure at the end of the line may become undesirably low as additional areas are connected to the water supply system.

Grid pattern with loops

In a grid pattern with loops supply system, all the pipes are interconnected in loops with no dead ends. Water can reach any point from more than one direction thus providing supply in case of pipeline blockage or breakage, and more even pressure at all outlets.

Advantages

- As water in the supply system can flow in more than one direction, stagnation is reduced.
- Water will flow to an area from an alternative direction in case of repair or break down in a pipe.
- Strategically located valves allow sections of line to be isolated for maintenance or repairs whilst supply continues to other watering points.
- Water reaches all points with minimum head loss.

Disadvantages

- Higher cost of pipe infrastructure because extra pipe is required.
- More valves are required.
- The calculation of pipe sizes can be more complicated. A pipe network analysis may be required to ensure sufficient flow rate and pressure at all locations or off-take points.

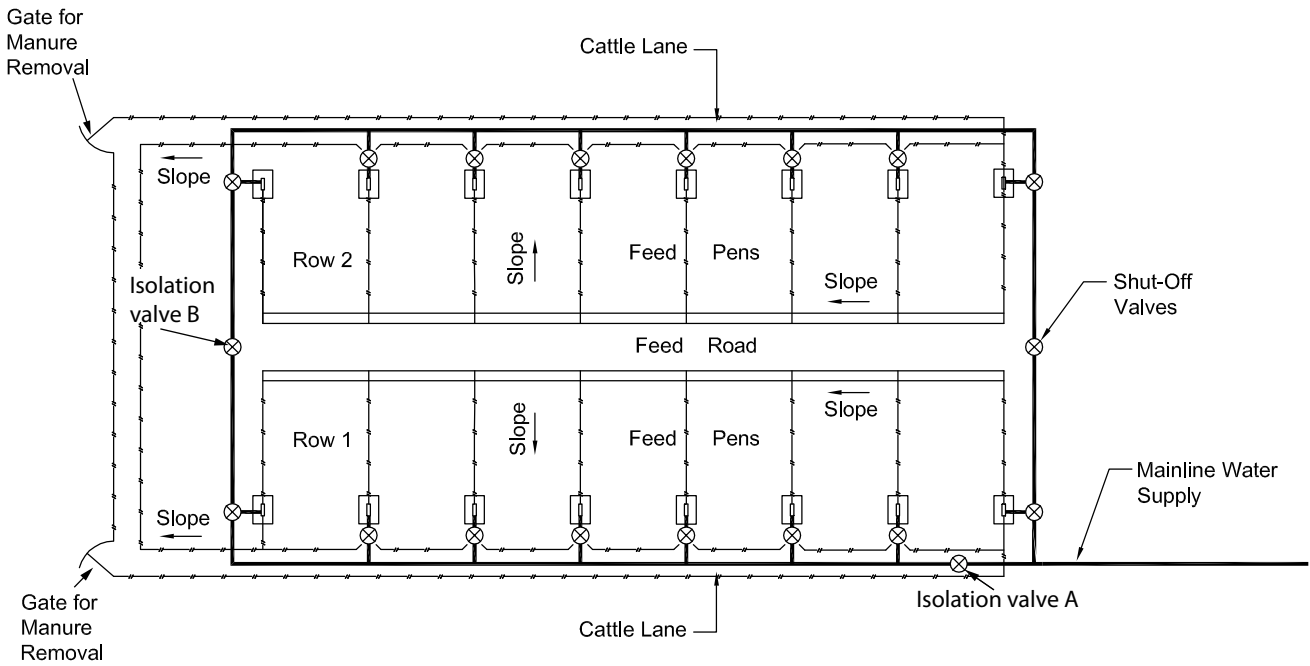

Figure 3. Loop water reticulation network (Refer to page 8 for explanation of isolation valves A and B)



Isolation valves allow water supply to be cut off for repairs.

Design considerations

Sizing

Each segment of the water pipeline network must allow the required amount of water to be delivered to each water delivery outlet at an acceptable pressure. Pressure losses can be attributed to the diameter and length of a segment of the water system; pipeline specification incorporates the operating pressure, pressure surges and the strength of the pipe.

It may be cheaper to use a heavier-walled pipe than the delivery pressure requires to provide durability, lengthen service timeframes and reduce potential repair costs. Fittings must be at least as strong as the pipeline.

Although demand flow rates in a feedlot can vary significantly, pipe size should accommodate maximum flow rates to ensure proper water distribution. The ultimate size of the feedlot should also be considered when selecting mainline and branchline pipe sizes.

The design flow rate for drinking water can be estimated using the information given in this section.

For most feedlots, pipelines to individual troughs will be 25 mm or 32 mm inside diameter. Main feeder line sizes will depend on the flow required and may range from 32 mm to 102 mm.

Coiled polyethylene pipe is usually used when pipe sizes 51 mm or less are required, and rigid PVC is used for larger piping. As a rule of thumb, lines to individual troughs should supply at least the daily peak consumption in a four-hour period (MLA, 2006). For example, in a pen of 100 head with a daily peak consumption of 60 L/head/day, the supply line should be able to provide about 25 litres per minute.

The relative elevations of water delivery points can be a factor in sizing. For example, if one trough is on top of a hill and a second trough is at the base of the hill, the trough at the base will require less pressure to operate and will get priority for the water supply. Inadequate water supply or under-designed piping will result in the lower trough getting all the water and the top trough getting none.

Materials

Whereas pumps, tanks and other water reticulation system components are replaceable, buried pipe has to remain in use for a long time. Therefore the quality of the pipe and fittings and the pipe size need to accommodate the ultimate size of the feedlot.

Typical materials used are polythene, PVC, galvanised steel, black steel and copper. Considerations for selecting the type of pipe include

- life expectancy
- resistance to corrosion
- resistance to deposits forming inside the pipe
- safe working pressure
- resistance to puncture and soil movement
- resistance to vehicle loads (traffic)
- standardised pipe size and fittings allows for easy repairs
- thrust blocks at all bends and junctions
- lengths available
- ease of bending
- comparative cost
- ease of installation
- type of pipe connection required.

Air relief valve

An air relief valve allows air that accumulates at high points of the water line to be released automatically so that it does not restrict water flow. If the water line velocity is high enough to force the air through the line, it can be released at a water delivery point.

Vacuum relief valve

When there are large differences in elevation, a vacuum relief valve will prevent vacuum in the line which can cause the pipe to collapse or break. This valve is typically used in conjunction with an air relief valve to minimise the number of fittings and reduce cost.

Advice should be sought on the location and requirements for check valves and air release valves. The pressure heads should be calculated to ensure that the correct pipe class is selected.

Shut-off valve

The pipeline network should include shut-off valves that allow sections of the line to be isolated for repairs and maintenance. The cost and location of valves should be evaluated against the benefit of having the water system remaining functional during repairs or service. A grid pipe network with loops enables most of the water system to remain pressurised and thus usable while a portion of it is isolated and depressurised.



Galvanised steel mainlines have been largely replaced by PVC and polyethylene because of its workability, ease of repair and cost.



PVC piping is a common mainline material, easy to install and repair. This installation incorporates a polyethylene pipeline take-off to the trough. Polyethylene pipe is now available in larger diameters (100 mm plus).



Shut-off valves allow individual troughs or rows of pens to be isolated without disrupting the water supply to other pens, or for purging pipes.



The PVC sleeve fitted over polyethylene pipe underneath the proposed concrete apron will make any replacement of the polyethylene pipe easier.



Polyethylene water pipeline attached to top rail of fence will allow water to heat up during hot weather and is not recommended.

Shut-off valves on each row of pens will allow maintenance to be performed on sub-mains without disrupting the whole feedlot. For example in Figure 3, if the sub-main to Row 1 was broken, valves A and B could be closed and the water supply to Row 2 is maintained.

The water supply to each trough should be controlled by individual shut-off valves on each unit (Figure 3). This will allow individual troughs to be shut down if a pen is empty or if a specific trough needs maintenance, without shutting down the rest of the system. If the pen has two troughs, its water supply will only be partially disrupted.

In smaller feedlots, this can be accomplished by using individual supply lines from the water supply to each trough. Separate lines installed to hospital pens will allow in-line medication to these pens only.

Valves should be installed at the low points in the system to allow flushing of any accumulated residue in the pipe network.

Location

The key issues to consider when locating water pipelines are physical damage by cattle or machinery, accessibility for maintenance or repairs and minimising heating of the water. Sub-mains may be located within pens or in cattle lanes/drains.

In some feedlots, the water pipe is attached to the top rail of the feedlot fence or water is reticulated through the top rail. Top rail piping must be steel since plastic pipes can be easily damaged. Although the water pipe is readily accessible for repairs, the cattle drinking water will become heated through solar radiation. This system is not recommended even though hot water can be partially overcome by continuous circulation. Cattle prefer water at or below body temperature (see *Section 5 – Water quality*).

Buried water pipes are less susceptible to physical damage by cattle or machinery but maintenance is more difficult and they can be damaged by soil movement.

Pipes buried at a depth of about 600 mm will maintain the water at a relatively constant temperature year round, with 300 mm giving fairly consistent temperature on a daily basis.

Most water pipelines are polyethylene or PVC as buried metal pipelines do corrode.

All buried pipeline joints should be watertight and tested before back filling with loose material such as sand or fine aggregate; rocks or coarse aggregate can damage the pipeline.

The relevant Australian Standards such as AS/NZS 2032 – 2006 and AS/NZS 2033 – 2008 should be referred to for design and installation of PVC and polyethylene pipelines.

A post-construction survey should mark pipeline locations. An accurate map showing locations of installed pipelines, valves and off-take points is an invaluable reference to limit damage in any future earth works.

Water meters

Water usage should be recorded regularly using water flow meters to monitor resource efficiency. Water flow meters are positioned in a straight length of pipe, typically with 10 pipe diameters of length upstream and 5 pipe diameters of length downstream of the meter. Various types of water flow meters are suitable for measuring water consumption in feedlots (Refer *MLA Tips and Tools Factsheet 4: Additional water measuring equipment*).

Flow meters are also useful for detecting possible leaks by measuring 'standing still' water consumption when equipment is not operating.

Flow meters may have a digital or an analogue display, and many can have data loggers fitted to record not only total flow but also provide profiles on how much water is used at various times of the day, month or year.

The cost of installing water flow meters will vary according to size and functionality. Factors to consider include pipe size, flow rate (L/min), fluid quality (e.g. incoming potable water, wastewater, process water), type of power supply (mains, battery or solar) and installation costs. There will also be costs for maintenance and recalibration for accuracy on a regular basis or according to the manufacturer's recommendations. Remember that any informed decision making must be based on accurate data.

Maintenance

Regular checks and maintenance of the watering system should ensure that an adequate supply of water is available to cattle at all times. Common problems are leaking blocked troughs, pipes and float valves which can usually be repaired quickly and inexpensively. Water leaks diminish feedlot appearance, propagate odour and enhance nuisance fly breeding while cattle may become bogged if the leak is significant or is allowed to persist.

Protection

Exposed items such as pumps, valves and pipelines need to be protected from damage by machinery and cattle.



Flow meters may have analogue or digital display. Digital meters can have data loggers.



Marking and recording the location and depth of underground mainlines will prevent unnecessary and costly damage.

Quick tips

- Gravity flow systems are preferred as they have less reliance on powered infrastructure and can provide cattle with water at all times.
- Whilst branched networks are simple, some areas will be without water until repairs are completed.
- A grid pattern pipe network with loops ensures that there is multiple supply of water to any one area.
- Minimise the heat gained by the water within the delivery system by running water pipes underground.
- The design of a reticulation system incorporates many factors including sizing, flow rates, pressure losses and valving. Consult a suitably qualified and experienced person in the design phase.
- Including water metering equipment in the reticulation system allows ongoing monitoring of water usage.
- Develop a water reticulation location map for future reference.

Further reading

MLA, 2011, A framework for water and energy monitoring and efficiency in feedlots, Factsheet 11: Drinking Water Usage. ISBN: 9781741915969 Meat & Livestock Australia, North Sydney NSW.

MLA, 2011, A framework for water and energy monitoring and efficiency in feedlots, Factsheet 4: Additional water measurement equipment. ISBN: 9781741915969 Meat & Livestock Australia, North Sydney NSW.

MLA, 2006, Summer feeding of feedlot cattle, Heat Load in Feedlot Cattle Tips and Tools, Meat & Livestock Australia, Meat & Livestock Australia, North Sydney NSW.

Standards Australia, AS/NZS 2566.1 – 1998, 2566.1 – Buried flexible pipelines – Part 1: Structural design. Standards Australia, Sydney.

Standards Australia, AS/NZS 2566.1 – 1998, 2566.1 – Buried flexible pipelines – Part 1: Structural design – Commentary. Standards Australia, Sydney.

Standards Australia, AS/NZS 2032 – 2006, 2032 – Installation of PVC pipe systems. Standards Australia, Sydney.

Standards Australia, AS/NZS 2033 – 2008, 2033 – Installation of polyethylene pipe systems – Incorporating amendments Nos 1 and 2. Standards Australia, Sydney.



FEEDLOT DESIGN AND CONSTRUCTION

15. Fences, gates and lanes

AUTHORS: Peter Watts, Rod Davis, Mairead Luttrell and Orla Keane

Introduction

Cattle housing and handling systems in a feedlot need well-designed fences, gates and lanes to ensure optimum animal performance, good animal welfare and to provide a safe environment for feedlot workers.

Design objectives

The design objectives for feedlot fences, gates and lanes are to

- keep cattle securely contained in production pens or laneways during movement around the feedlot
- allow safe and efficient movement of cattle
- minimise stress and injury to cattle
- not hinder pen and drain cleaning
- not hinder the movement of feed trucks and pen cleaning equipment
- minimise ongoing maintenance costs
- provide a safe working environment for pen riders and other feedlot personnel.



Steel pipe is probably the most common material for fence line posts. Concrete 'post pots' reduce corrosion and also damage by pen cleaning equipment.

Mandatory requirements

There are no specific mandatory requirements associated with the design of fencing, gates and lanes.

Design choices

Fencing

Cattle are strong and inquisitive animals and will play with any loose fittings that they can reach. To remove their winter coats and to relieve itching, cattle will rub on anything that is available and this is usually the fencing.

The construction materials and the fence design selected will depend on the frequency of yard use, with commercial feedlots requiring more robust fencing than opportunity feedlots. Fences must be economical to build and maintain; they must contain stock but not hinder pen drainage or cleaning.

Overall design

Figure 1 shows the various aspects of fence design. Fencing for a commercial feedlot often has the following features

- posts
- cables
- top rail
- belly rail
- post 'flower' pot (concrete fence post base for corrosion protection and water shedding)



Secondhand or surplus materials from other industries are commonly used e.g. railway line and bore casing.

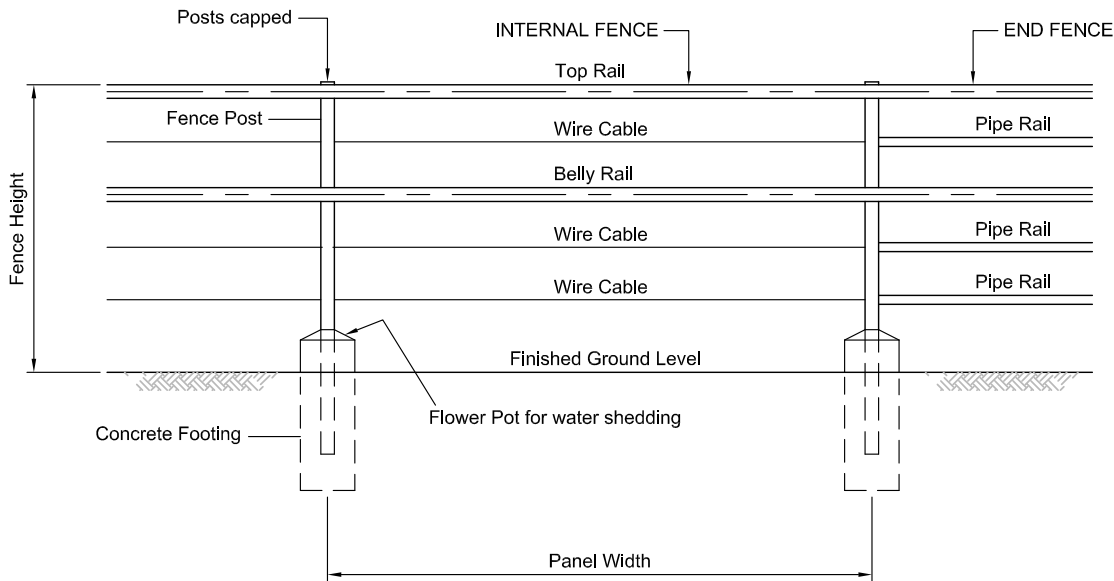

Figure 1. Typical fence design for commercial feedlot

Fence posts

Fence posts are generally made from either steel or timber. Wooden posts should be at least 250 mm in diameter with corner and gate posts 300–350 mm in diameter. All wooden posts should be set at least 900 mm into the ground. If timber posts are to be concreted into position, the post should protrude below the bottom of the concrete to allow water to drain out and prevent the post from rotting. Steel posts need to be set in concrete 900 mm below ground level with the concrete finishing about 200 mm above ground level in a ‘flower pot’ or post pot, to reduce corrosion at ground level. Hollow steel posts should be capped to prevent rainwater entry and subsequent corrosion.

Fence height

Feedlot pen fences are usually about 1.5 m high, but may need to be higher (1.6–1.8 m) for cattle not accustomed to handling. For handling yards, fences should be at least 1.7 m high and up to 2.0 m high for cattle not accustomed to handling.

Panel width

The distance between fence posts, or panel width, influences the cost of fencing. Wider panel spacing is more economical to construct and more efficient to clean under. As a 3.2 m panel takes about the same time to clean as a 2.4 m panel, about 25% more fence will be cleaned under in a similar time. Panel widths should not exceed 3.2 m as these would reduce the strength of the fencing. Strainer panels or end assemblies are required at the end of each length of fencing.

Cables

There are many different types of cables. The more elastic ‘curly’ type is preferred as it does not require a turnbuckle or similar device for tensioning, whereas straight wire cable does need turnbuckles to be installed on strainer posts to allow periodic re-tensioning.



Good quality timber is becoming difficult to source. A steel capping rail will prevent posts without concrete footings from leaning under pressure from cattle.



Steel top and belly rails with cables



External eyelets hold cables running past steel posts. Hollow posts are capped to exclude water.

Cables should be kept reasonably tight although some ‘give’ is allowed for contraction in cool weather; turnbuckles should be loosened a little during the winter to reduce the strain on the posts.

Ideally, fences will include five rows of cables and rails to allow under-fence cleaning while preventing cattle escaping by rolling under the cable.

Cables should be attached to, or directed through, fence posts so that no sharp edge can deteriorate the cable as it moves constantly back and forth under pressure from the cattle. Cables can be run through holes in wooden posts; steel posts require hollow sleeves or external eyelets. Cable wear, corrosion and ongoing maintenance are important considerations in deciding the most practical applications.

Top rails and belly rails

Top rails and belly rails add strength to a fence. Top rails stabilise fences from leaning over and provide a baulk for cattle when cattle continually rub and push the fence. Belly rails help to prevent cattle from escaping from pens where the cables have stretched or become loosened, and allow cattle to rub on solid infrastructure.



Cables passing through steel fence posts need a steel sleeve to reduce fraying. Sleeves prevent water entering the hollow post but can accumulate moisture which accelerates corrosion of the cable. This is an expensive fabrication technique.



The height of the bottom cable must allow under-fence cleaning, Some flexibility in the strain reduces damage. Here, curly cable is used only in the lowest cable.



Cable tension control using a wedge-lock system that was developed in the construction of pre-stressed concrete.



Cable tension is achieved and maintained by locking the cable in the railway line using chain links.



Cable clamps are often used to retain cable tension.

Top rails and belly rails and posts can be either wood or steel. Wooden rails should be at least 150 mm in diameter and steel rails at least 100 mm in diameter. Steel used for top rails and belly rails needs to be strong, ideally round pipe or heavy walled RHS.

Gates

The size and location of gates are important; they must provide good, safe access to the pens for both pen cleaning equipment and stock. Any unnecessary gates, particularly across access points, should be eliminated as they add to the capital cost of the feedlot and can cause delays for machinery and cattle movement throughout the feedlot.

Gate location

Most feedlots require a gate at the rear of pens for movement of stock and pen cleaning equipment, and another across the feed bunk apron for easy cleaning of aprons and movement of pen riders between pens (see pen layout figure in Section 9).

Stock movement gates are usually located at the bottom of the pens near the drains or cattle lane. Figure 2 shows a gate that requires cattle and pen cleaning equipment to make a tight 90 degree turn into a pen.

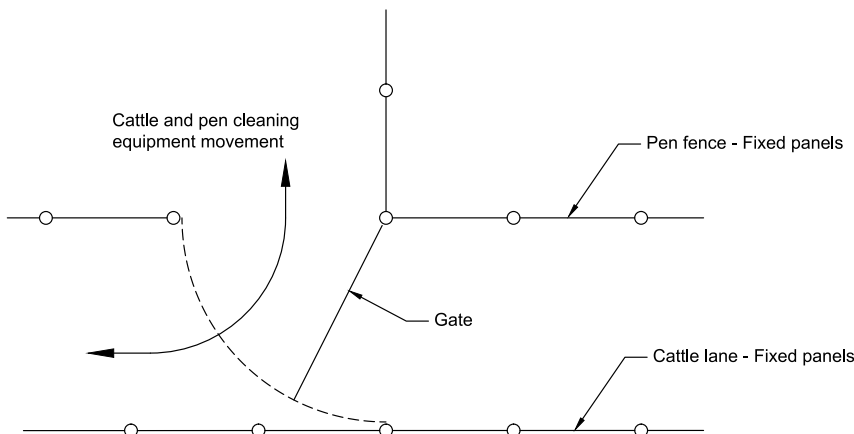

Figure 2. Pen entrance gate without the herringbone tapering

Figure 3 shows a herringbone configuration for gates that provides good access for pen cleaning equipment and promotes good, safe stock flow.

Herringbone gates facilitate entry of pen cleaning machinery into the pen and work well when the flow of cattle movement is in one direction. However, cattle in the lane have to enter the pen at an acute angle if they approach the gate from the wrong side. If cattle are required to approach from either direction, gates should be installed on each side of the herringbone pen. In most good layouts, cattle approach pens from one direction only and therefore only one gate is required and a fixed panel can face the gate.

Gates for stock and machinery movement should ideally be the same width as the stock lane. When the pen entrance gate is swung across the lane, the cattle can flow well into or out of the pen. A wide cattle lane will need a double gate arrangement to close off the lane.



Cables can pass through wooden posts minimising corrosion and cable fraying. This fence line has no top or belly rail.



Strainer panels or end assemblies are required at the end of each length of fencing.



Strainer assemblies across gate openings provide structural stability for both the gateway and cable tension.



Welded-on round barrel hinges are simple and effective. The swing angle can be limited by the way the hinges are mounted to one side of the post.



The circular grip on this telescopic pipe latch minimises the risk of pen riders getting snagged. Half circle gate stops prevent cattle damaging the latch when rubbing and allow the gate to be opened in one direction only.



There are many designs for gate latches

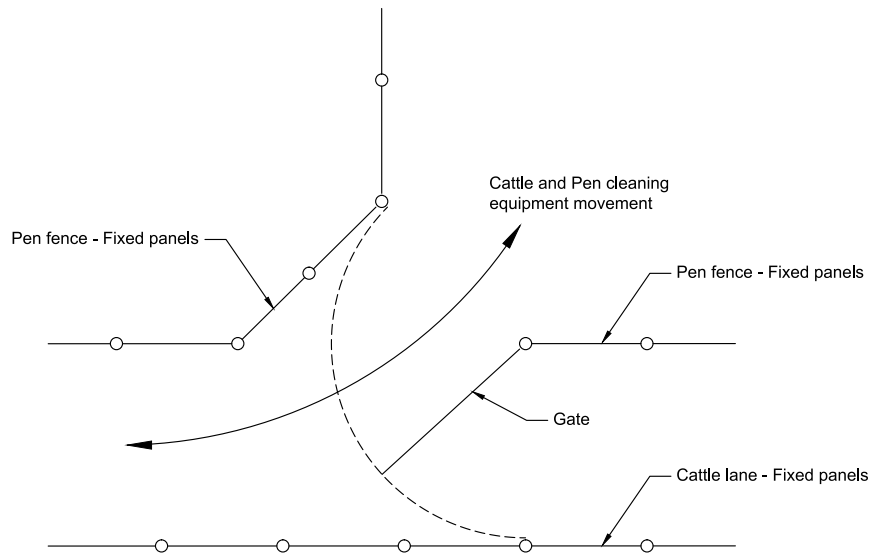

Figure 3. Pen entrance gate in a herringbone arrangement

A gate across the feed bunk apron at the top of each dividing fence between pens allows the full length of the feed apron to be cleaned in a single pass.

Feed bunk gates should be wider than the concrete apron and be able to swing fully open to rest against the subdivision fence line. These gates also provide pen rider access between pens.

Gate latches

Gate latches should be designed so that pen riders can safely open the gate without dismounting from their horses, and should prevent curious cattle from working out how to open the gate. There are many designs for gate latches.



Wide lanes require wide gates. Double gates are preferable when lane width exceeds about 4.5m.

Gate construction

Gates should be lightweight but strong. Strength can come from a wide, ribbed solid panel of steel at the mid-height of the gate. This also tends to baulk the cattle and they do not knock the gate around so much. Gates should not have any sharp protrusions such as badly positioned hinges and latches that cattle can bump into and be bruised by as they move in and out of the pen. Ideally all gates should lay flat against the fence line when open.

Lanes

A good lane system will promote efficient movement of cattle, pen cleaning equipment and pen riders throughout the feedlot facility with a minimum number of gates and lanes crossing roadways and drains.

Lane width is important. Lanes that are too narrow (less than 4 m wide) can choke cattle movement while lanes that are too wide (greater than 6 m) allow cattle to turn around easily and come back on themselves and pen riders. All tight corners and unnecessary gates should be eliminated.

Feedlot designs can have either separate cattle movement lanes and drains or combined lanes and drains. Separate cattle lanes and drains should have a total width of 5–7 m to allow for easier drain cleaning (see Section 10).

Layouts with a combined cattle lane and drain are usually about 4.5 m wide as gates for stock movement limit the width. This design may be preferred since cattle movement along the drains scuffs up the manure, promoting more rapid drying. However, cattle may also 'bog-up' the drain, impeding water flow.



Typical double herringbone gate arrangement provides good access for pen cleaning machinery and cattle, but from one direction only.



A gate in the pen fence line across the feed bunk apron allows easy access by pen cleaning and maintenance equipment, and by pen riders. Gates require a strainer assembly for support.



Cattle lanes behind angled pens that are not parallel. Angled gate openings allow easy access for pen cleaning machinery and cattle but only from one direction.



A wide cattle lane allows plenty of room for under-fence cleaning and manure removal...



...but an unfenced wide lane usually requires more than one stockman to move cattle.

Quick tips

- Fences must contain stock and should be economical to build and maintain.
- Fence posts are generally made from either steel or timber.
- Wooden posts should be at least 250 mm in diameter with corner and gate posts 300-350 mm in diameter.
- If timber posts are to be concreted into position, the post should protrude below the bottom of the concrete to allow water to drain out and prevent the post from rotting.
- Steel posts should be set in concrete with the concrete finishing about 200 mm above ground level in a 'flower pot' or post pot to reduce corrosion at ground level.
- Cap hollow steel posts to prevent rainwater entry and subsequent corrosion.
- Strainer panels or end assemblies are required at the end of each length of fencing.
- If straight wire cable is used, turnbuckles (or similar) must be installed on strainer posts to allow periodic re-tensioning of cables.
- Wire turnbuckles together to prevent cattle unwinding them.
- Cables should be kept reasonably tight although a small amount of 'give' should be allowed for contraction of cable in cool weather.
- The lowest fence cable should be high enough to allow under-fence cleaning but low enough to prevent cattle escaping by rolling under the cable.
- Gates will be required at the rear of pens for movement of stock and pen cleaning equipment.
- Gates across the feed bunk apron at the top of each dividing fence between pens facilitate cleaning of aprons and movement of pen riders between pens.
- Design gate latches so that pen riders can safely open the gates without dismounting and so that curious cattle cannot work out how to open the gate.
- Gates should not have any sharp protrusions, i.e. hinges, latches.
- Position hinges so that gates lay flat against the fence line when open.

Further reading

DAFF, 2013, Australian Animal Standards and Guidelines for Cattle, Department of Agriculture, Forestry and Fisheries, Australian Government, Canberra, ACT.

Gahan RJ and Johnston BD Handling Cattle from Farm to Abattoir. Bulletin, NSW Agriculture, Orange

Gill, R. and Machen, R, n.d., Cattle Handling Pointers, Texas AgriLife Extension Service. College Station, Texas, Texas A&M System.

Grandin, T, n.d., Cattle Behavior During Handling and Corral Design for Ranches, Beef Cattle Handbook, Colorado State University, Colorado, BCH-9003.

Grandin, T – Livestock Handling from Farm to Slaughter, *www.grandin.com*

MLA, 2012a, National Guidelines for Beef Cattle Feedlots in Australia. Meat & Livestock Australia, Sydney, NSW.

MLA, 2012b National Beef Cattle Feedlot Environmental Code of Practice. Meat & Livestock Australia, Sydney, NSW.

NSW Government, 2005, Handling Cattle, Agfact A0.1.2, NSW Department of Primary Industries.

www.thompsonlonghorn.com.au

University of Arkansas, United States Department of Agriculture, and County Governments Cooperating, Cattle Working Facilities MP239

Worksafe Victoria, 2006; Beef Cattle Handling: A Practical Safety Guide, 1st Edition, Victorian Workcover Authority.



FEEDLOT DESIGN AND CONSTRUCTION

16. Shade

AUTHORS: Mairead Luttrell and Orla Keane



Shade structures – longitudinal rows



Shade structures – central square



Shade structures – separate panels

Introduction

Cattle have a remarkable ability to cope with environmental stress but a combination of high temperature and humidity, with high levels of solar radiation and minimal air movement, can exceed the animal's ability to dissipate body heat.

Excessive heat load (EHL) in feedlot cattle during summer months can result in significant production losses, animal welfare problems and under extreme conditions, the death of cattle. Shade structures are one strategy that has been used to reduce the impact of heat wave conditions on cattle.

Shade is a thermal radiation shield that reduces heat load on the animal. Shade does not readily affect air temperature but can reduce exposure to solar radiation and also enhance minimal air movement for cooling. Major design considerations for shade structures are orientation, space, height and shading material.

Design objectives

The design objectives for a shade structure are to

- provide adequate shade for each animal in the pen (square metres per animal)
- provide a structurally sound and durable structure
- minimise obstructions when cleaning the pen
- maximise air flow under the shade
- maximise pen drying under the shade
- design a structure that suits the geographical location.

Mandatory requirements

The Australian Animal Welfare Standards and Guidelines for Cattle (DAFF, 2013) states

S10.4 A person in charge must do a risk assessment each year for the heat load risk at the feedlot and implement appropriate actions to manage ongoing heat load risk.

S10.5 A person in charge must have a documented Excessive Heat Load Action Plan and must implement appropriate actions in the event of a heat load emergency.

Technical requirements

Any shade should be designed and constructed in accordance with the Australian Standards for Wind Loads – AS 1170.2.

Shade area per animal

Cattle will use shade when it is available. Lot feeders who have installed shade for cattle have provided between 1.6 m² and 6 m² of shade per head. Shade structures suitable for Australian conditions should ideally provide more than 2 m² of shaded pen floor space per animal, recognising that it is beneficial to spread cattle during excessive heat load events. Overcrowding cattle under shade during normal summer conditions will limit any potential production benefit.

Shade options

Each feedlot has its own distinctive location, topography, climatic conditions, cattle breeds, feeding categories, customers and capital capability. The choice of shade structure and materials for the feedlot will depend on a number of these factors.

Types of shade structure

Three types of shade structure can be used in feedlots

- longitudinal rows – long thin shade structures that stretch over many different pens
- centre squares – large tent-like structures in the centre of the pen
- separate panels – structures connected in a grid-like pattern and providing alternating shade spots through each pen.

Spacing in shade structure

Both longitudinal row and centre squares shade structures may have spaces or gaps throughout the structure to encourage the pen floor to dry during the day and to increase air flow. Sunlight reaching different parts of the pen at different times of the day should prevent a buildup of wet manure.

With longitudinal rows, these spaces may run along or across the rows. Spaces within the structure encourage cattle to stand in groups and to move across the pen following the shade areas. This decreases site specific wet spots and also promotes airflow.

A disadvantage with centre square structures is that a portion of the pen will always be in the shade and hence will remain wet.

The area of shade provided by the shade structures and the frequency of the spacing in between is important as narrow strips of shade with a high frequency of spacing can result in the cattle bunching and over-heating.

Orientation

Orientation of the structure will determine the pattern of the shade underneath and also the amount of shade available to the cattle. The best orientation may depend on the overall design of the feedlot pens, the local climate and the prevailing winds that assist in ventilation and cooling.

The orientation of the longitudinal row shade structure should be north-south, especially if it has no strips to allow for drying, while the orientation of centre square and separate panel structures is unimportant.

Longitudinal row shade structures positioned in the north-south direction with the shade material orientated east-west can have the eastern side of the structure elevated to provide a 10-15° pitch. This encourages better pen floor drying in the morning hours, provides more shade area during the afternoon and increases air flow under the shade structure. A north-south orientation works well with a compacted clay or gravel floor because the sun strikes every part of the pen floor under and on either side of the shade at some time during the day.



Insufficient shade area can result in cattle bunching and over-heating



Orientation of longitudinal row – shade area at midday (above) and during the afternoon (below)





Clear-span structures minimise columns within the pens. Columns are best positioned in the subdivision fence lines.



Too many support posts make pen cleaning more complicated; fewer structures would need to be strengthened. Encasing posts in concrete protects them from corrosion, damage during pen cleaning and reduces injury to cattle.



Shading material is often supported on cable suspended between columns, posts or supports. Infrastructure must be engineered for rain, hail and wind loadings.

Position in the pen

Shade structures are typically erected towards the centre of the pens so that cattle can follow the shaded area as it moves across the pen during the day.

Shade positioning should take advantage of the morning sun for drying while maximising the shaded area in the afternoon summer sun.

Shade should not be positioned over water troughs or near a fence line; water troughs and feed bunks should be kept outside the shaded area (particularly in the hottest time of the day). Ideally, strips of shade should be constructed parallel to the feed bunk but not close to it. Shade over the troughs or bunks encourages cattle to congregate around them, limiting access for extensive periods while increasing pen surface pitting in these already high traffic areas.

Support posts and cables

Obstructions in the pen should be minimised to allow easy cleaning and less risk of animal injury. Clear-span structures are preferred with few or no support posts in pens. Separate panel shade structures do not require any posts in the pen to hold them up as a cable network is constructed with posts on the fence line. However, fewer support structures means that they will need to be engineered to support the shading material and withstand the force of high winds, and hence are more costly. Support posts should preferably be in line with the perimeter fences. Centre square and longitudinal row shade structure often need support posts within the pen and this can create areas which are extremely difficult to clean.

Columns are commonly made from steel but the base should be encased in concrete to prevent corrosion, to provide better protection from equipment damage during pen cleaning operations and to reduce injury to cattle that bump into them.

Roofing material is often supported on cable strung between supports that are determined by calculated engineering load. Cables should be storm rated for the feedlot site but should be at least 11mm cable to ensure good tension and long life. The thread should be high density, low shrinkage, abrasion resistant and unaffected by cleaning agents, acid rain, mildew, chlorine, saltwater and industrial pollutants. End assembly strainers should be outside the pen.

Shade material

The most commonly used shading materials are shade cloth and galvanised iron sheet (Table 1).

Shade cloth is available in many densities and strengths. It is generally manufactured from lightweight knitted or woven polypropylene fabric that is resistant to rot and mildew, does not become brittle and is water permeable. It provides a good shade, reflects heat, diffuses light, has long life and is easily supported with adequate assemblies.

Knitted shade cloth is heavy duty with a longer life expectancy. Polypropylene woven shade cloth is slightly cheaper, has a considerably shorter life expectancy and has a tendency to unravel and fall apart if not taped. Woven synthetic shade materials are available in varying degrees of strength and texture. However,

Table 1. Advantages of shade cloth and iron sheeting for shade

Shade materials and structures		
	Shade cloth	Iron sheeting
Suitability	May be retractable allowing pens to dry out in winter months.	Typically permanent fixed shade structures.
UV radiation protection (UPF)	UPF varies with colour, fabric density and degree of stretch (from <50% to >90% UPF). A shade rating of 90% will give a UPF of only 10.	Excellent protection with UPF 50+.
Light transmission	Lighter colours allow more light but reflect and scatter more UV radiation.	None.
Solar heat gain	Barrier to direct solar radiation while allowing ventilation. Darker colours are hotter and reflect less UV radiation.	Better thermal performance if painted white on topside.
Structural implications	Minimal down or uplift force as material is porous (if clean). Shade cloth can be damaged by wind unless sufficiently tensioned.	Requires well-engineered support structures fixed to manufacturer's specification and designed to wind codes and potential loads.
Permeability	Mainly permeable unless sealed with dust. Pen maintenance problems if the area beneath shade becomes permanently wet.	Not permeable, but can concentrate heavy runoff leading to pen maintenance issues.
Ease of replacement	Readily available. Re-fitting is generally easy and low cost.	Material readily available and easily fitted.
Maintenance requirements	Keep clear of tree debris. Dust can reduce porosity, increase tension and concentrate heavy rainfall on the down slope.	Requires minimal maintenance to the structure itself. Remove all metal shards after installation to prevent staining and corrosion under moisture.
	Needs to be at an appropriate height to allow machinery and vehicles access to the pen.	Water runoff on down slope side under heavy rainfall can create wet patches, increasing pen maintenance.
	Retractable shade cloth can allow pens to dry out in winter.	Wet shaded areas may cause dags on cattle, increasing maintenance requirements.
Life span	About five years depending on location, less in windy locations. Retractable shades generally last longer if stored appropriately.	Long life if well maintained. Fixings and flashing materials should have a lifetime similar to that of the roof covering material.

woven shade cloth can accumulate dust and so become impermeable to rain and hail while also harbouring birds and rodents.

A reinforcing tape border around the shade panels prevents the cloth from unravelling, and must be used when grommets are inserted to allow cables to be used to secure the shade cloth to the support posts. For shade cloth without grommets, shade clips can be used to attach the shade cloth to structures or wire supports. No tools are required and the clips simply snap into place.

Corrugated roofing iron requires more support through the structure but has the advantage of being self-cleaning in rain, sheds heavy rain and hail, provides increased rigidity in high winds, is resistant to birds and rodents and has a longer life span than shade cloth.

Iron sheeting can also reflect solar radiation; a silver or white coating on the surface can significantly reduce radiant heat.

Height of shade structure

Higher structures will allow better ventilation but result in increased wind loads and costs. As low shade cloth structures may discourage cattle from entering an area the minimum height is 4 m, but 5 m will reduce the risk of pen cleaning machinery tearing cloth with an extended loader bucket or tipping tray, or burning holes in it with an exhaust pipe.

Shade height also determines the area of shade cast at different times of the day.



Shade structures should be high enough for machinery. Higher shade structures offer better ventilation but limit the area of shaded footprint and have higher wind loading.



With galvanised iron sheets in hotter climates a pitch of 1:3 increases air movement and shade coverage in the afternoon.



Retractable shade improves drying of pen surface during winter months in high rainfall areas.



This shade can be retracted using a pulley system connected to the PTO shaft of a tractor.

Inclination of shade structure

Inclined shade structures may increase the sunlit area in the morning and extend shade coverage in the afternoon sun, thereby increasing the shadow area accessible by cattle. Sloping fabric will shed more rain water.

Shapes that have little curvature and tension will deform under load and become unstable and move about. Outside the agricultural industry, the best shade designs from a structural stability perspective are thought to be shade sails that have a significant difference in height of posts, where one corner is much higher than the other. The shade sail is essentially pulled taut and twisted so one axis is convex and the other axis concave.

With suspended iron sheeting, a lower pitched roof (1:4 pitch or less) can result in lower air movement whereas a steeper roof pitch results in greater air movement (e.g. 1:3 pitch is suggested for a hotter climate).

Retractable shade structures

Shade can be retractable so that it can be removed during the winter when not required, especially in winter rainfall regions. Retracted shades help to keep the pen surface dry when evapo-transpiration is low. Retracting shade cloth helps prolong its life. Other shade cloth structures can be removed for winter periods but need to be stored correctly to maintain life expectancy.

Rainfall zone

Rainfall zone can influence the type of shade to be used. Feedlots located in winter-dominant rainfall areas would favour north-south orientation with retractable shade cloth, as this would allow for optimum pen drying.

In high rainfall areas, solid shade covering can concentrate runoff resulting in ponding on the pen surface. The pen floor beneath the shade must be given the opportunity to dry when the sun is shining.

Structural design

Shade cloth needs to be structurally sound in order to withstand wind loads. The impact of excessive wind load at the feedlot site should be considered in the design of an appropriate shade structure and accompanying strengthening assemblies.

The movement of wind against a solid structure results in directional loads on the structure. Wind moving against a wall causes a static side load. As wind moves up and over an inclined surface roof structure, it causes a download on the front face of the roof and an upload on the leeward face as a result of an induced area of low pressure. These forces must be taken into account when designing a shade structure, especially if the shade itself is sloped to obtain advantages in shading and ventilation. A sloping shade structure will act either as a wing or as an aerofoil depending upon the direction of the wind.

Structural design should be undertaken by a suitability qualified, licensed and experienced structural engineer.

Preparing a shadow diagram

A shadow diagram should be prepared to ascertain how a shade structure is likely to affect the shadows cast.

The following figures are provided to illustrate the preparation of a shadow diagram for a feedlot site.

1. Place the north point on the plan.
2. Determine the angle (azimuth) of the sun (Figure 1) at the feedlot site for three or more times during the day e.g. 9 am, 12 noon and 3 pm (Figure 2). Solar azimuth and elevation calculations can be obtained from the internet.
3. Determine the shadow cast by a structure of unit height at each time of day. The shadow length is calculated by multiplying the height of the structure by the shadow cast length (Figure 3).
4. Project the shadow cast onto the site layout. The effect of width and height of shade structure on the amount of shade cast can be analysed by varying the parameters of the shade structure. Figure 4 steps lot feeders through the process of preparing a shadow diagram.



Corrugated iron sheets can concentrate rainfall runoff to localised areas; ponding will damage the pen surface.

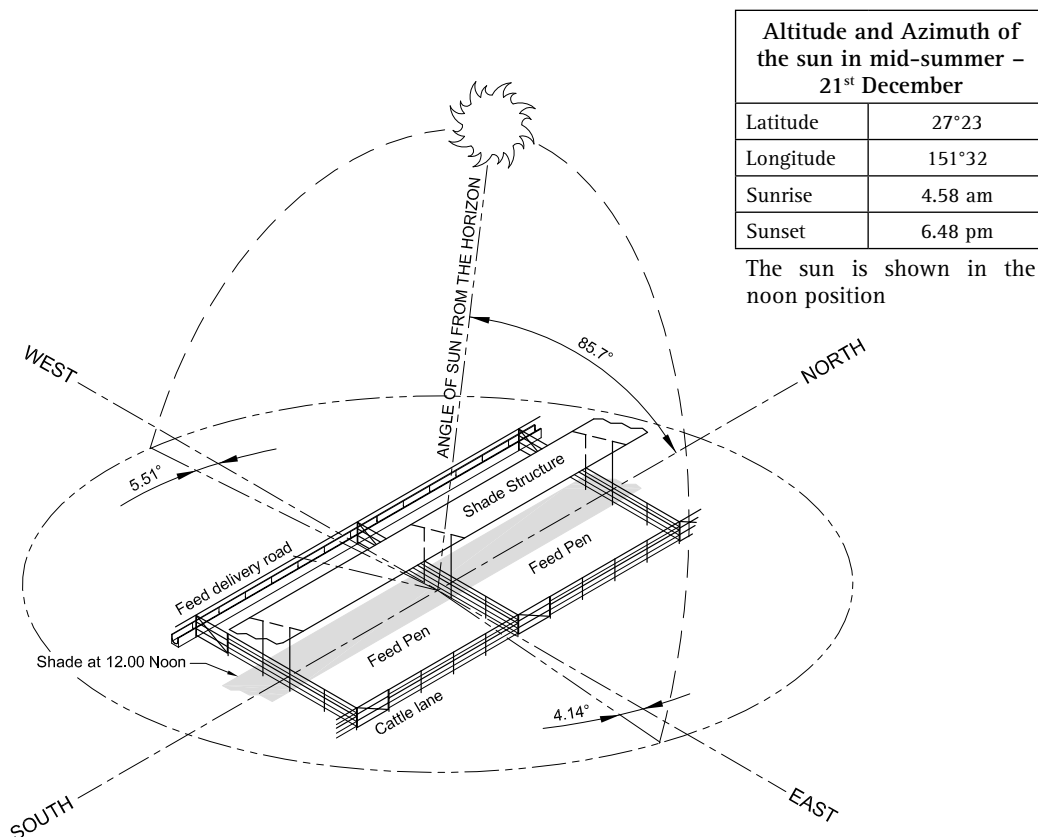

Figure 1. Altitude and azimuth of sun in mid-summer



Shade sails should be pulled taut and twisted so one axis is convex and the other axis concave. Shapes with little curvature and tension will deform under load and become unstable. Sloping fabric will ensure good shedding of water and hail.



A taut peaked shade cloth structure. Sloping fabric will ensure good shedding of water and hail.

Time	Angle (°) (azimuth)
09:00	94
12:00	337
15:00	264

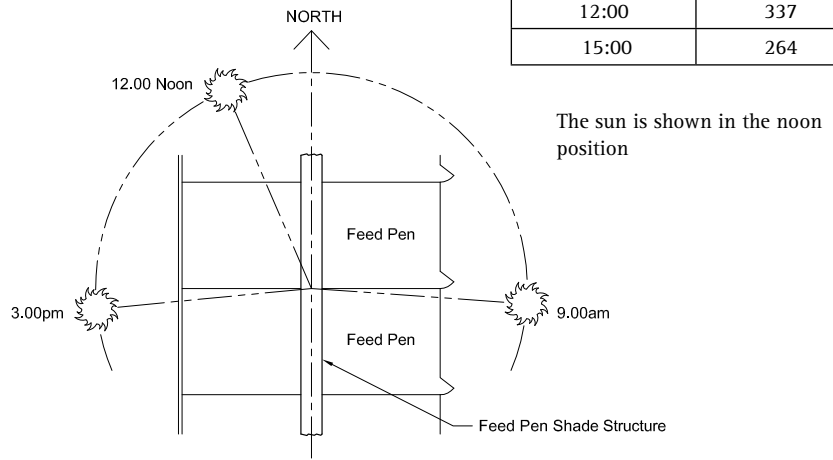

ANGLE OF SUN FROM TRUE NORTH ON 21st DECEMBER (AZIMUTH)

Figure 2. Azimuth of sun in mid-summer at three times during day

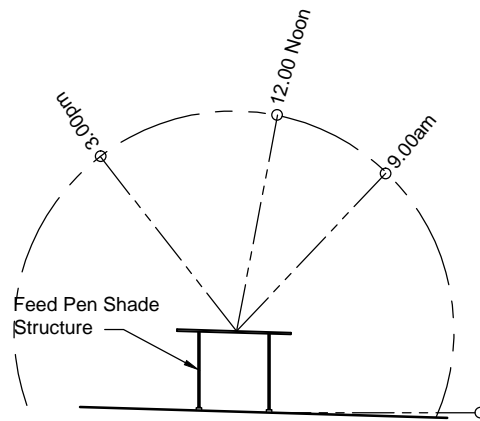

ANGLE OF SUN FROM THE HORIZON ON 21st DECEMBER (ALTITUDE)

Time	Angle (altitude)	Length of shadow cast by a 1m pole on flat land (m) (shadow length - Multiplier)
09:00	51	0.81
12:00	86	0.08
15:00	48	0.91

Figure 3. Length of shadow cast

STEPS IN PREPARING A SHADOW DIAGRAM

STEP 1.
Show North Point
on Site Plan

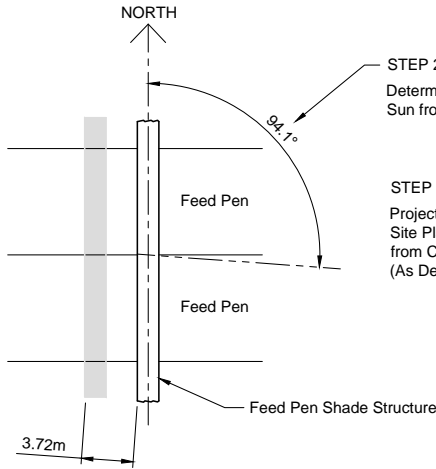

STEP 2.
Determine angle (Azimuth) of
Sun from Chart '1' for 9.00am

STEP 4.
Determine Shadow
Lengths from Chart '2'

STEP 5.
Project Shadow Lengths on
Site Plan at the Angle Derived
from Chart '1'
(As Determined in STEP 2.)

STEP 6.
Shade Shadow Areas

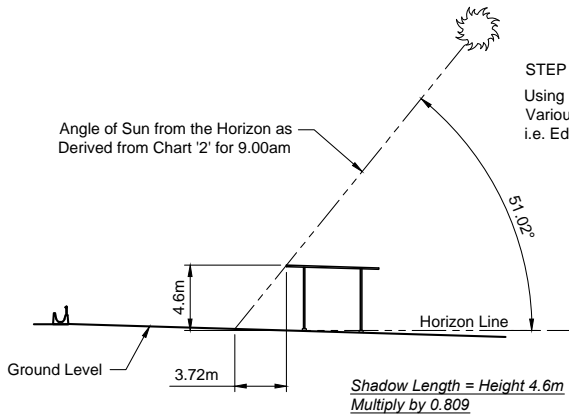

STEP 3.
Using Elevation Drawings Determine
Various Heights of Building Extremities.
i.e. Edge of Roof Line of Shade Structure.

STEP 7.
Now do the same for 12.00 Noon and 3.00pm so as to Produce Three Shadow
Diagrams to Scale as in the Example

Figure 4. Determining shadow length



Cattle bunching under limited afternoon shade.



The advantages of using either shade cloth or corrugated iron sheeting are listed in Table 1.

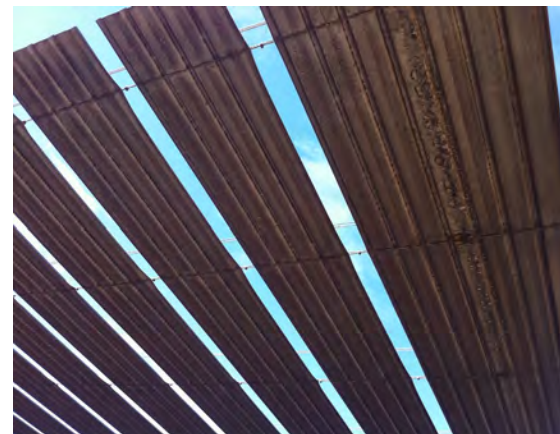

Quick tips

- Seek professional advice from a structural engineer when designing shade structures.
- Use shade cloth with a minimum solar rating of 80%, minimum 300 GSM (gram per square metre) and at least a 10-year warranty against UV degradation. Green or black material is recommended.
- Apply sufficient tension to shade cloth to prevent damage during windy conditions. Monitor tension regularly, especially after strong winds.
- A greater pitch is better than a low pitch structure as it enhances convective air movement, encourages dust/rainfall run-off and enhances drying during sunlight periods.
- Support posts used should be graded structural steel with the base encased in concrete to prevent corrosion and damage by pen cleaning machinery. Minimise the number of posts located in the pens.
- Galvanised iron sheets reflect more solar radiation.
- A minimum height of 5.0 m at the lower side of the shade should promote airflow and provide adequate clearance for pen cleaning machinery.

Further reading

DAFF, 2013, Australian Animal Standards and Guidelines for Cattle, Department of Agriculture, Forestry and Fisheries, Australian Government, Canberra, ACT

MLA 2001, Recommendations for reducing the impact of elements of the physical environment on heat load in feedlot cattle, FLOT.307. Meat & Livestock Australia Ltd. North Sydney, NSW

MLA 2001, Measuring microclimate variations in two Australian feedlots. Final Report FLOT.310. Meat & Livestock Australia Ltd. North Sydney, NSW

MLA 2002, Heat stress software development. FLOT.312. Meat & Livestock Australia Ltd. North Sydney, NSW

MLA 2002, Forecasting feedlot thermal comfort. FLOT.313. Meat & Livestock Australia Ltd. North Sydney, NSW

MLA 2003, Applied scientific evaluation of feedlot shade design. FLOT.315. Meat & Livestock Australia Ltd. North Sydney, NSW

MLA 2003, Development of an excessive heat load index for use in the Australian feedlot industry. FLOT.316. Meat & Livestock Australia Ltd. North Sydney, NSW

MLA 2003, Measuring the microclimate of eastern Australian feedlots. FLOT.317 Meat & Livestock Australia Ltd. North Sydney, NSW

MLA 2003, Refinement of the Heat Load Index Based on Animal Factors. FLOT.319 Meat & Livestock Australia Ltd. North Sydney, NSW

MLA 2003, Operation of a Weather Forecasting Service for Several Locations for Excessive Heat Load Events Over Summer 2002/2003 For The Australian Feedlot Industry FLOT.320 Meat & Livestock Australia Ltd. North Sydney, NSW

MLA 2004, Refined website based weather forecast service for the Australian feedlot industry, FLOT.324 Meat & Livestock Australia Ltd. North Sydney, NSW

MLA 2004, Cattle heat load forecasting service for 2004/2005 summer, FLOT.324 Meat & Livestock Australia Ltd. North Sydney, NSW

MLA 2005, Reducing the Risk of Heat Load for the Australian Feedlot Industry. FLOT.327. Meat & Livestock Australia Ltd. North Sydney, NSW

MLA 2005, Validation of the Heat Load Index for use in the feedlot industry, FLOT.330 Meat & Livestock Australia Ltd. North Sydney, NSW

MLA 2006, Tips and Tools Feedlots. Heat Load in Feedlot Cattle. Meat & Livestock Australia Ltd. North Sydney, NSW

MLA 2006, Cattle Heat Load Forecast Service for 2005/2006 Summer , FLOT.334 Meat & Livestock Australia Ltd. North Sydney, NSW

MLA 2006, Improved measurement of heat load in the feedlot industry, FLOT.335 Meat & Livestock Australia Ltd. North Sydney, NSW

MLA 2006, Revision of the Risk Analysis Program, FLOT.336 Meat & Livestock Australia Ltd. North Sydney, NSW

MLA 2007, NSW Cattle heat load forecasting summer 2006-2007, FLOT.340 Meat & Livestock Australia Ltd. North Sydney, NSW

EA Systems Pty Ltd, 2003, Applied scientific evaluation of feedlot shade design. Commercial-in-confidence, Final Report FLOT.315. Meat & Livestock Australia Ltd, North Sydney, NSW



FEEDLOT DESIGN AND CONSTRUCTION

17. Pen and road surfaces

AUTHORS: Rod Davis and Ross Stafford

Introduction

The design, construction and maintenance of pen and road surfaces are important for their long-term performance. Pen surfacing has a large impact on sustainability, environmental outcomes and long-term maintenance costs while roads are complex engineering structures upon which feed delivery and reliable access to the feedlot depend. The complete surface may include one or more layers (i.e. a base course and sub-base) but must have a strong and stable underlying foundation (subgrade). If the surface sub-layers or the subgrade are weak through inadequate design, poor quality materials, poor construction techniques or poor maintenance practices, the final surface will have reduced life.

Surfaces are generally unbound natural material such as gravel, crushed rock or sand, but bound pavements (asphalt, cement) may be used on some high-usage roads.

The construction of pen and road surfaces comprises the supply and processing (as necessary) of the suitable material, hauling the material to the site of the works, spreading the material on the prepared subgrade (foundation), compacting the material to the required standard (density and moisture content) and shaping the surface of the compacted material to the alignment, grades, cross sections and thickness required.

Design objectives

Pen and road surfaces should be designed and constructed to

- withstand the bearing weight of cattle and pen cleaning equipment
- be durable and resist damage from cattle pawing and licking
- be durable and resist damage from feed delivery vehicles
- have a long life
- require low maintenance
- be easy to clean
- withstand the anticipated traffic loads and frequencies
- allow adequate drainage
- prevent or minimise adverse impacts on groundwater and surface waters.

Mandatory requirements

Compliance with

- National Guidelines for Beef Cattle Feedlots in Australia (MLA, 2012a)
- National Beef Cattle Feedlot Environmental Code of Practice (MLA, 2012b)

The National Guidelines for Beef Cattle Feedlots (MLA, 2012a) state that

- If a groundwater assessment indicates a high potential for contamination of underground water resources because of leaching of nutrients through permeable, underlying rock strata, an impermeable barrier will be needed between the contaminant

and the groundwater. This is required if the permeability of underlying soil/rock strata exceeds 0.1 mm/day.

- Clay liners should have a maximum permeability of 1×10^{-9} m/s (~ 0.1 mm/day) for distilled water with 1 m of pressure head.

Design choices

The following factors should be considered in determining the final surface design and in the choice of surfacing materials to be used

- climate
- available materials – location in relation to works, workability, durability, permeability
- subgrade variability, strength and drainage
- spectrum of traffic axle loads and frequency
- sequence of earthworks construction
- the presence or otherwise of weak layers below the subgrade level
- the compaction, moisture content and field density specified for construction
- effects of subsurface drainage on moisture content
- cross section chosen for the surface
- use of subgrade or surface stabilisation
- use of staged construction
- the equipment the contractor has available
- ongoing and long-term maintenance requirements
- dust management strategy.

Typically, pen and road surface construction will include the following works

- selection of surfacing material
- conditioning and compaction of the subgrade including the removal and replacement of any unsuitable material
- placement of surfacing material and compaction
- surface finish (e.g. sealing).

Subgrade preparation

The subgrade is the prepared surface (foundation) on which the pen and road surface is constructed and provides support to the pen or road surface. In most feedlot design situations, the subgrade is the layer of soil (cut or fill) prepared during bulk earthworks. Bulk earthworks are discussed in *Section 8 – Bulk earthworks*.

Selection of materials

Generally accepted materials for pen and road surfacing are varied and cover different types of crushed/decomposed rock, crusher product mixed with binder, natural gravels (e.g. pit, ridge, creek or waterworn material) and sand-clay mixes of various quality. Materials such as asphaltic concrete and concrete are unlikely to be used in an open feedlot but may be used in a covered feedlot.



Good quality construction materials are essential for feedlot pen and road surface construction and reduced maintenance costs.

The selection of the materials depends on

- available materials at or close to the construction site
- degree of processing required to obtain conforming material (unbound, bound)
- workability
- durability
- cost.

To produce compliant material, processing may be required. Processing involves crushing, screening and recombining of materials, combining with other materials (including the addition of water as necessary) and any other operation carried out to produce the required final material.

Properties of materials

Typically, the material properties required for pen and road surfaces are those that are to be exhibited by the material after placement and compaction.

Samples of the material that is intended to be used as surfacing material should be tested before it is selected and delivered to the construction site. Soil aggregates should be of uniform quality and free from organic matter, lumps of clay and any other deleterious material.

A materials quality test should be conducted in accordance with relevant Australian Standards. Generally, the tests outlined in Table 1 should be conducted as a minimum.



Coarse-graded material used in road construction— larger stones have been graded to the shoulder.

Table 1. Recommend engineering tests for soil samples

	Australian Standard	Performance criteria required for pens	Performance criteria required for roads
Particle size distribution (grading)	AS 1152	Grading C or D are recommended for pen surface materials. Refer to Table 2 for suggested grading limits.	Grading A and B are suited for bottom course of roads. Grading C or D are recommended for top course for roads. Refer to Table 2 for suggested grading limits.
Soaked CRB value	AS 1289.6.1.1-1998	The National Guidelines for Beef Cattle (MLA, 2012a) state a minimum standard CBR wet and dry of 20% for pen surface. Refer to Section 8 - Bulk earthworks, Table 2 for typical range of CRB values for different soils types.	Preferable CBR is between 30 and 45 with a minimum of 15.

If a sample fails any of the preliminary tests, the material should be rejected as unsuitable for the works.

Grading requirements

The material used for surfaces should be a uniformly blended mixture of coarse and fine aggregate (an even grading). The material should be free from cobbles greater than 75 mm and free from clods, stumps, roots, sticks, vegetable matter or other deleterious materials.

In the absence of technical specifications or experience, the grading limits for ‘coarse-grained’ pen and road surface material (i.e. material having 10 mm or greater nominal maximum size) are suggested in Table 2.

Table 2. Suggested grading limits for pen and road surfaces materials

AS 1152 sieve size (mm)	Percentage (by weight) passing sieve			
	Grading A	Grading B	Grading C	Grading D
75.0	100			
53.0	80–100	100		
37.5	60–100	85–100	100	
19.0	40–75	55–90	80–100	100
9.50	30–55	40–70	55–90	80–100
4.75	20–45	28–55	40–70	55–90
2.36	15–35	20–45	30–55	40–70
0.425	5–20	10–25	12–30	20–40
0.075	3–12	4–15	5–20	8–25

Grading A and B is a coarse grading suitable as a bottom course for roads but not as top course (surface) material. Grading C or Grading D are recommended for use as pen surface materials and/or as a top course for roads.

Stabilisation

Stabilisation is a technique that can be used to increase the strength and durability of pen and road building materials. Stabilisation can be used on both the subgrade as well as the surface materials. *Section 10 – Pen and road stabilisation* provides further information on pen and road stabilisation.

Road cross section

Roads are usually designed and then constructed with careful consideration given to correct shape of the cross section. The design objective is to keep water drained away from the roadway. A road cross section has three components – a crowned driving surface, a shoulder area that slopes away from the edge of the driving surface and a drain to remove the water away from the road.

Figure 1 shows a typical cross section of an unsealed gravel road.

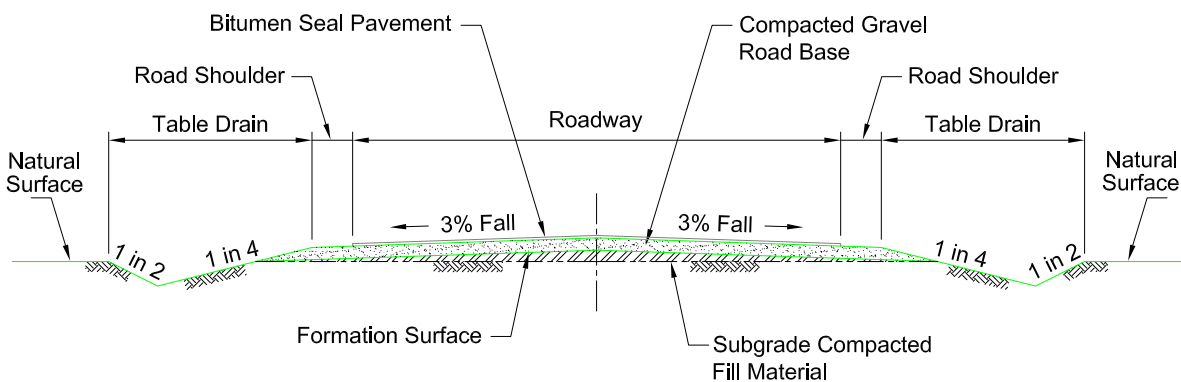

Figure 1. Typical unsealed road cross section

Figure 2 shows a typical cross section of an unsealed feed road in a sawtooth or single row pen layout. The fall is away from the feed bunk.



Even grading material on turnaround results in little displacement of coarse material.

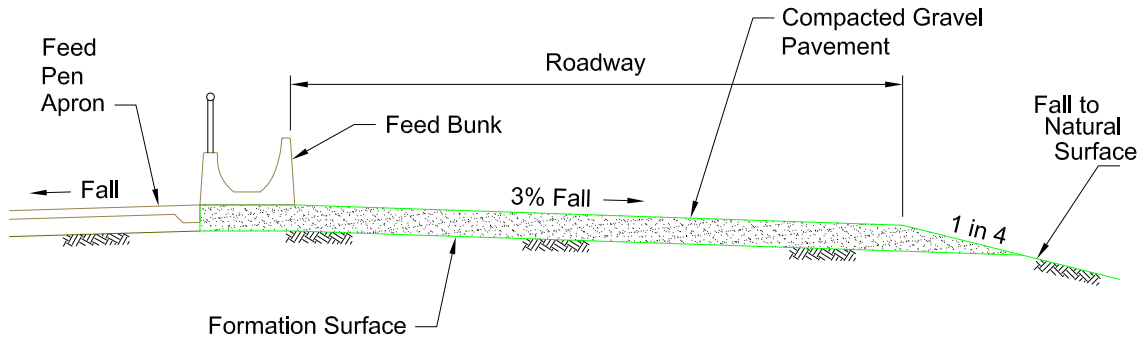

Figure 2. Typical unsealed feed road cross section in a sawtooth or single row pen layout

The cross-fall on the finished compacted gravel surface should be about 3% in dry regions and 3–6% in wet regions. Steeper cross-falls may result in erosion by rain.

Most feedlot roads are unsealed gravel. Sealed roads, whilst a higher capital cost, allow the roadway to keep its shape for a longer period of time and reduce maintenance and dust generation. However, they are more expensive to repair if the subgrade/pavement or seal does eventually fail.

With unsealed roads, gravel tends to be displaced from the surface to the shoulder area during dry weather and they tend to rut more easily in wet weather. Unsealed roads should be constructed and maintained to ensure that there is no standing water within the cross section.

In order to maintain an unsealed road properly, grader operators must clearly understand the need for a crowned driving surface and a shoulder area that slopes directly away from the edge of the driving surface to allow water to drain away.

Figure 3 and Figure 4 show typical cross sections for an unsealed feed road in a back to back pen layout. In a back to back pen layout, the design choices for feed road cross sections include a cross-fall towards the centre or no cross-fall. All configurations must have a longitudinal fall along the length of the road.

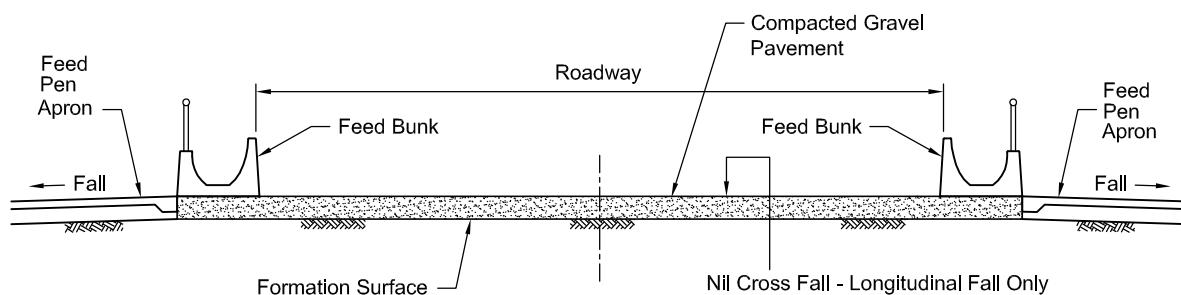

Figure 3. Typical unsealed feed road cross section with no cross-fall in back to back pen layout.

Figure 3 illustrates a feed road cross section with no cross-fall. In this arrangement water is shed along the road and not concentrated along a centre drain. This cross section is easier to maintain with grading machinery when feed roads are narrow.

Figure 4 illustrates a feed road cross section with cross-fall to the centre of the roadway. Water is shed to the centre of the roadway and then longitudinally along the centreline of the roadway with the gradient fall. This drain needs to be kept clean to prevent blockages

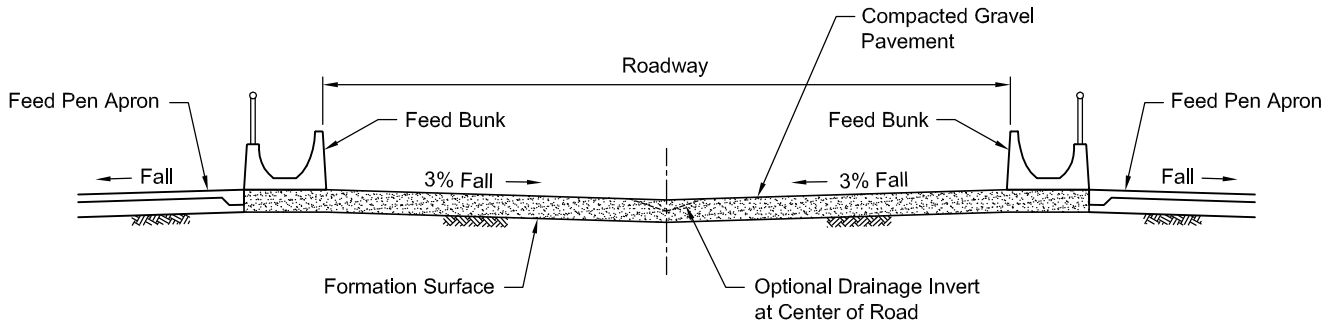

Figure 4. Typical unsealed feed road cross section with back to back pen layout and fall to centre

while a concreted v drain in the centre of the roadway would minimise erosion. The roadway needs to be wide enough for grading machinery to grade each cross-fall section individually. This design is best suited to sealed feed roads and allows water to be shed quickly off the pavement, minimising moisture penetration into the subgrade.

Surface material loss

Surface material is lost from the unsealed road surface through the action of rain, traffic wear, and as dust. The rate of loss partly depends on the rainfall and traffic characteristics. Alignment, gradient, surface cross-fall, road width, material quality, compaction and maintenance practices can be expected to all significantly influence rates of material loss. Surface material loss is specific to the material used and the location. Surface material loss and dust may influence other environmental considerations.

Structural thickness

Thickness design is not normally used for gravel surfacing for roads and/or pens at feedlots, but the surface must be thick enough to spread the load of the traffic so that the underlying subgrade is not stressed.

In the absence of roads specifications or recommendations based on experience, the thicknesses outlined in Table 3 are suggested.

Table 3. Recommended compacted gravel thicknesses for pens and roads

Subgrade strength – in-situ soil	Roads – Design traffic – ESA ¹		Pens – Design vehicle – FEL ²	
	1 x 10 ⁶ (mm)	2 x 10 ⁶ (mm)	Loaded 14.0t (mm)	Unloaded 7.25t (mm)
Strong foundation – CBR >15 – Well-drained sand (SW,SP)	200	225	150	150
(Little traffic damage if earth road is properly shaped to drain rainwater away)				
Intermediate foundation CBR = 4–5 – silty clay – poorly drained	380	420	250	180
Weak foundation CBR = 2–3 heavy plastic clay – poorly drained	630	670	360	260

¹ESA – Equivalent Standard Axles – Defined as a single axle with dual wheels that carries a load of 8.2t.

²FEL – Front end loader



Road cross section – back to back layout with cross-fall to centre of the feed lane and longitudinal fall along the road

Constructions

Surface material should be placed and compacted on a pre-shaped (cambered) and compacted subgrade. Water should be added if necessary to obtain good compaction (as close as possible to optimum moisture content).



Road constructed from even grading material—well maintained by regular cleaning and grading.

If two or more materials are to be combined to produce the required final material, the mixing (including the addition of water) should preferably be carried out in a processing plant. Alternatively the component materials may be uniformly spread and mixed in place on the subgrade unless specified otherwise in the earthworks specifications.

If the specified compacted thickness of the base or sub-base is 150 mm or less, the material should be spread and compacted in one layer.

If the specified compacted thickness of the base or sub-base is more than 150 mm, the material should be spread and compacted using more than one layer. The compacted thickness of each layer should not be less than 75 mm or more than 150 mm.

The principal concerns during construction of a road or pen surface should be

- The formation or foundation for the surfacing material should be properly shaped and compacted beforehand. The drainage system must be adequate and functioning properly.
- Surface material quality should be carefully controlled, and an appropriate level of testing carried out, if feasible.
- Layer thickness control is essential; simple pegs or profile boards may be used for this purpose. Initial checks should be made on number of loads delivered loose per unit length of road. Regular checks should be made by excavating through the compacted gravel surface.
- Large (oversize) particles should be removed by screening or grading to the outside/shoulder.
- The laid surface material should be at a moisture content suitable for compaction. If necessary, water should be added.
- Compaction by vibrating roller will considerably improve durability of the surface material. The loose surface material must be spread evenly before compaction to ensure a uniformly dense and even surface.
- Finished compacted cross-fall (2–6%) should be checked using a camber board or template, or strings stretched longitudinally, transversely and diagonally between the setting out pegs.

Surfacing

Pens

Various materials can be used for the pen surface. These include overlaying the subgrade with a gravel capping, compacting in-situ material (clay/gravelly clay) to obtain the required standard, or lining the subgrade (clay/gravelly clay) with imported material to obtain the required standard. Some features of gravel and clay pen surfaces are

- gravelled pen surfaces are harder on cattle hooves; large, sharp angular gravel should be removed
- gravel pen surfaces are more durable and can withstand higher loading
- gravel is removed if manure is cleaned back to the gravel surface; manure will require screening before utilisation
- clay pen surfaces may need to be stabilised to improve trafficability



Final trim operations result in a well-prepared pen surface.

- clay pen surfaces are more erodible
- clay pen surfaces are more difficult to manage in wet weather
- clay pen surfaces require more repairs.

Table 2 provides grading requirements for materials for pen surfaces. Grading C or D should be used.

Irrespective of the material chosen for the subgrade and surfacing of the feedlot pens, the construction must ensure that the permeability requirements set out in the National Feedlot Guidelines are achieved.

Roads

The main reasons for bound surfacing of feedlot roads is not for structural purposes, but for dust suppression, improved water shedding, reduced maintenance or reduced wear on vehicles. The bound surfacing most applicable to a feedlot development can be classified as

- sprayed bituminous seals
- asphalt (hot mix).

The cross section of the road is important when roads are to be bound surfaced.

Sprayed bituminous seals

Sprayed sealing has relatively low cost and is faster than other forms of pavement surfacing. However, it is less able to resist the effects of heavy traffic, particularly when vehicles are turning.

Common materials used in sprayed sealing are

- bitumen – Class 170 (approximately equivalent to 85/100 penetration)
- cutback bitumen – used for sealing, generally C170 mixed with cutter as required or priming/primer sealing
- cutter oil – a light solvent such as lighting kerosene or aviation turbine fuel
- bitumen emulsion – generally Australian Standard grades of cationic emulsions, with specialty grades developed for priming
- aggregate pre-coating materials – oil- or bitumen-based or a specialty grade of bitumen emulsion
- adhesion agents – to promote wetting and adhesion in damp conditions, and for aggregates with poor affinity to bitumen.

For spray seals the quality of the aggregate is critical, with the nominal size of aggregate related to the various conditions of the site. A single-sized aggregate is preferred because this provides maximum tyre contact and macro texture for surface drainage. With the expected traffic volume of feedlot roads, typical aggregate sizes should be no greater than 10 mm for single seals.

Gravel material may be available on site but should be tested to determine if it is suitable for use as a seal aggregate. On-site material, whilst cost effective, may be of a lower grade and may not be able to adequately support heavy loads, resulting in a loss of texture early in the seal life.



Poorly graded material being used in pen repairs – note the large percentage of fines.



Watering roads will maintain surface integrity, reduce corrugations and reduce dust.



Gravel loss and structural issues are most common on road curves where shear stresses from vehicle loadings are the highest. Bitumen seal on road curves reduces road maintenance but potholes can form easily at the transition with the unsealed section.



Rutting on a sealed road with poorly prepared subgrade.



Manure stockpile areas need an impervious base with good site drainage to withstand heavy loads and equipment.

For roads carrying heavy vehicles, more expensive crushed rock material may have to be imported as the surface material. The sprayed treatments are broadly separated into prime and seal. A prime and seal is the preferred treatment for all new work as it improves the bond, provides flexibility and reduces the risk of early seal failure.

There is no typical formal design method, and the selection of a suitable grade of cutback bitumen primer is based on experience within the local area, construction practices, type and compaction of surfacing material and the seal to follow. The primer should be allowed to dry and cure for a minimum of three days before being sealed.

Specialist advice should be obtained on bitumen seal from a designer suitably qualified and experienced in the area of road pavement design.

Asphalt

Asphaltic surfacing is more expensive than sprayed sealing.

Asphaltic surfacing is an engineered product composed of about 95% stone, sand, and gravel by weight, and about 5% asphalt cement, which is a petroleum product. Asphalt cement acts as the glue to hold the surfacing together. Asphaltic surfacing is often referred to as 'hot mix'.

Asphaltic surfacing is typically placed with a minimum thickness of around 20–25 mm. The main characteristics of asphaltic surfacing are the use of a heavy tack coat or sprayed seal to form an integral bond with the underlying surface, and the adoption of coarse gap-graded mixes to provide good surface texture. Asphalt requires a well-prepared surface before installation. The clay content, plasticity and grading of the surface material is more selective than that required for spray seal.

Asphaltic surfacing is often preferred in colder climates but avoided in hotter climates, where the asphalt can become soft and prone to ruts and bumps.

Typically, asphalt surfaces are not placed during cooler weather. Mixing and placing asphalt should not be permitted when the surface of the road is wet or is at a temperature less than 10°C, or there is a likelihood of cold winds chilling the mix to an extent that spreading and compaction are adversely affected.

Specialist advice should be obtained on surfacing options from a designer suitably qualified and experienced in the area of road pavement design.

Rutting

Even when shaped properly, unsealed roads may fail when exposed to heavy loads as a result of weak subgrade strength and marginal gravel depths. On sealed roads, rutting also may occur in the asphaltic mixture near the surface. Even proper maintenance will not address rutting if the design of the surface is poor.

Manure stockpiling and composting areas

As feedlots pens have to be cleaned regularly, harvested manure has to be stored and processed before it can be utilised.

The main design considerations for the manure stockpile and composting areas are

- an impervious base
- good site drainage
- sufficient area.

Solid waste storage areas must have an impervious base that can handle heavy traffic. The soils used for lining this area must have the same properties as those for holding pond clay liners (see *Section 12 – Holding pond design*).

The base of the solid waste storage should

- be constructed to achieve a maximum permeability of 1×10^{-9} m/s (0.1mm/day) for distilled water with 1 m of pressure head
- have sufficient depth so that the integrity of the structure is maintained throughout general operations, including the movement of heavy loads and equipment
- remain durable and effective when subjected to the physical effects of machinery and water flow, or be overlain by a suitable depth of a durable material (e.g. gravel) that can adequately protect the lining material under these conditions.

The manure stockpiling or composting area should sit within the controlled drainage area, with diversion banks (or the natural topography) diverting external 'clean' runoff away from the area. Runoff caught within the area must be directed to the holding pond, with any spills from the manure stockpiling area to be handled in accordance with licence conditions.

Good drainage with an even slope of 1–3% within the manure stockpiling or composting area will prevent formation of wet patches that can destroy the integrity of the base. Manure windrows should be orientated with the long axis down the slope to promote drainage.

The area for manure stockpiling or composting needs to be large enough to store and process the expected amount of manure, and to allow for contingency storage. The required area will depend on the amount of manure harvested from the pens, the length of time the manure is stored and the processing method.



Composting areas also need an impervious base and an even slope of 1–3%.

Quick tips

- A strong and stable underlying subgrade is the key to a successful surface.
- A weak subgrade or surface sub-layer either through inadequate design, poor quality materials, poor construction techniques or poor maintenance practices, will reduce the surface life.
- Weak subgrade or surface sub-layers may need to be stabilised to improve strength and workability.
- Material used for road and pen surfaces should be a uniformly blended mixture of coarse and fine aggregate and free from cobbles greater than 75 mm, clods, stumps, roots, sticks, vegetable matter or other deleterious materials.
- Proper shaping of roads to provide a crowned surface will facilitate draining of water from the road and reduce maintenance requirements.
- Seek specialist advice on bitumen sealing of roads as sub-layer material needs to be more selective when compared to unsealed roads.

Further reading

Austrroads 2006a, Update of the Austrroads Sprayed Seal Design Method. Austrroads Technical Report, AP-T68/06, Austrroads, Sydney.

Austrroads 2006b, Specification framework for polymer modified binders and multigrade bitumen. AP-T41/06, Austrroads, Sydney.

Austrroads, 2009, Guide to Asset Management Part 5: Pavement Performance, Publication No AGAM05-09, Austrroads, Sydney.

Austrroads, 2012, Guide to Pavement Technology Part 2: Pavement Structural Design, Publication No AGPT02-12, Austrroads, Sydney.

Austrroads, 2009, Guide to Pavement Technology Part 8: Pavement Construction, Publication No AGPT08-09, Austrroads, Sydney.

Austrroads, 2006, Guide to Pavement Technology Part 4D: Stabilised Materials, Publication No AGPT04D-06, Austrroads, Sydney.

Austrroads, 2009, Guide to Pavement Technology Part 4L: Stabilising Binders, Publication No AGPT04L-09, Austrroads, Sydney.

Austrroads, 2008, Guide to Pavement Technology Part 4F: Bituminous Binders, Publication No AGPT04F-08, Austrroads, Sydney.

Austrroads, 2009, Guide to Pavement Technology Part 4K: Seals, Publication No AGPT04K-09, Austrroads, Sydney.

Austrroads, 2009, Guide to Pavement Technology Part 8: Pavement Construction, Publication No AGPT08-09, Austrroads, Sydney.

Austrroads, 2007, Guide to Pavement Technology Part 4B: Asphalt (in Appendix A), Publication No AGPT04B-07, Austrroads, Sydney.

Austrroads, 2012, Guide to Pavement Technology Part 2: Pavement Structural Design, Publication No AGPT02-12, Austrroads, Sydney.

Austrroads, 2012, Guide to Pavement Technology Part 2: Pavement Structural Design, Publication No AGPT02-12, Austrroads, Sydney.

Austrroads, 2009, Guide to Pavement Technology Part 3: Pavement Surfacing, Publication No AGPT03-09, Austrroads, Sydney.

- Austrroads, 2007, Guide to Pavement Technology Part 4B: Asphalt, Publication No AGPT04B-07, Austrroads, Sydney.
- Austrroads, 2012, Guide to Pavement Technology Part 2: Pavement Structural Design, Publication No AGPT02-12, Austrroads, Sydney.
- Austrroads, 2009, Guide to Asset Management Part 5: Pavement Performance, Publication No AGAM05-09, Austrroads, Sydney.
- Standards Australia 2008, Residual Bitumen for Pavements, (AS 2008-1997), S Australia (ed.), Standards Australia, Sydney, NSW.
- Standards Australia 1998, Methods of testing soils for engineering purposes - Soil strength and consolidation tests: Determination of the California Bearing Ratio of a soil, Standard laboratory method for a remoulded specimen, (AS 1289.6.1.1-1998), S Australia (ed.), Standards Australia, Sydney, NSW.
- Standards Australia 2003a, Method 5.1.1: Soil compaction and density tests - determination of the dry density/moisture content relation of a soil using standard compactive effort, (AS 1289.5.1.1-2003), Standards Australia, Sydney, NSW.
- Standards Australia 2008, Determination of Linear Shrinkage of Soil, (AS 1289.3.4.1), Standards Australia, Sydney, NSW.
- Standards Australia 2009a, Methods of testing soils for engineering purposes - part 3.1.1: soil classification tests - determination of the liquid limit of a soil - four point casagrande method, (AS 1289.3.1.1-2009), Standards Australia, Sydney, NSW.
- Standards Australia 2009b, Methods of testing soils for engineering purposes - soil classification tests - determination of the plastic limit of a soil - standard method, (AS 1289.3.2.1-2009), Standards Australia, Sydney, NSW.
- Standards Australia 2009c, Soil classification tests - Calculation of the plasticity index of a soil, AS 1289.3.3.1-2009, SAI Ltd (ed.), Standards Australia International Ltd, Sydney, NSW.
- Standards Australia 2009d, Soil classification tests - Determination of the particle size distribution of a soil - Standard method of analysis by sieving, AS 1289.3.6.1-2009, SAI Ltd (ed.), Standards Australia International Ltd, Sydney, NSW.



FEEDLOT DESIGN AND CONSTRUCTION

18. Pen and road stabilisation

AUTHORS: Rod Davis and Ross Stafford

Introduction

Stabilising pen surfaces to provide a solid surface improves animal welfare by minimising contact between resting animals and wet mud and manure. Road subgrade or road surfaces may be stabilised to increase strength and durability or to prevent erosion and dust generation.

Pen surfaces may be stabilised during the initial construction or as a remedial action after the surface has broken down. Surface material stabilisation involves altering the properties of one or more materials, by mechanical or chemical means, to improve the desired engineering properties. The effect of a hard cement-stabilised surface on animal movement is not known.

The materials available for feedlot construction vary between regions and all may have different engineering properties. These materials have to be tested to establish suitable chemical additives and admixture rates to achieve the desired engineering properties.

The method of stabilisation selected should be verified in the laboratory before specifying or ordering materials, and certainly before construction. For example, the in-situ material may have low loadbearing strength because of an excess of clay, silt or fine sand. Within a reasonable distance, suitable granular materials may occur that may be blended with the existing in-situ material to achieve the design specification at a much lower cost in manpower and materials than importing material for surfacing.

Liquid dust suppressants have been used for unsealed roads. Whilst some dust suppressants may provide short term solutions to dust generation, they are invariably applied from the surface and not mixed with the surface materials. Hence, the use of externally applied dust suppression is not stabilisation. Applying dust suppressants from a moving water cart uses a far larger amount of product than incorporating them into the surface material inside a mixing chamber. For the material specifications and tests required please refer back to Section 17 – *Pen and road surfaces*.

Design objectives

The objective of stabilising pen and road surface material is to

- blend available materials so that, when properly compacted, they give the desired stability
- provide a hard surface to minimise damage when pen cleaning
- withstand the bearing weight of cattle and pen cleaning equipment
- be durable and resist damage from cattle pawing and licking
- minimise gravel loss and dust from feedlot roads
- reduce frequency of pen and road maintenance
- utilise in-situ materials and/or readily available local materials
- withstand the anticipated traffic loads and frequencies
- prevent or minimise adverse impacts on groundwater and surface waters
- selectively improve high wear areas (e.g. behind feed bunks, around water troughs).

Mandatory requirements

Compliance with

- National Guidelines for Beef Cattle Feedlots in Australia (MLA, 2012a)
- National Beef Cattle Feedlot Environmental Code of Practice (MLA, 2012b)
- relevant Commonwealth, state and local authority codes, regulations and relevant Australian standards as applicable to the feedlot development.

The National Guidelines for Beef Cattle Feedlots (MLA, 2012a) state that

- If a groundwater assessment indicates a high potential for contamination of underground water resources because of leaching of nutrients through permeable, underlying rock strata, a impermeable barrier will be needed between the contaminant and the groundwater. This is required if the permeability of underlying soil/rock strata exceeds 0.1 mm/day.
- Clay liners should have a maximum permeability of 1×10^{-9} m/s (~ 0.1 mm/day) for distilled water with 1 m of pressure head.

Design choices

Material can be stabilised many ways but all can be categorised as

- mechanical stabilisation, or
- chemical stabilisation.

Some stabilisation techniques use a combination of the two methods.

Mechanical stabilisation relies on physical processes to stabilise the material, either altering the physical composition of the material (blending) or placing a barrier in or on the material to obtain the desired effect.

Chemical stabilisation relies on the use of a binder to alter the chemical properties of the material to achieve the desired effect (such as using lime to reduce a material's plasticity).

Mechanical stabilisation

Mechanical stabilisation through material blending or screening is the most economical and expedient method of altering the existing material. When material blending is not feasible or does not produce a satisfactory result, geotextiles, soil reinforcing or chemical admixture stabilisation should be considered. If chemical stabilisation is being considered, determine what binders are available for use and any special equipment or training.

Mechanical stabilisation is valuable but has limitations. The principles of mechanical stabilisation have frequently been misused. For example, clay has been added to 'stabilise' soils when adequate compaction would be sufficient; understanding the densification that can be achieved by modern compaction equipment should prevent a mistake of this sort. In the same way, poor trafficability of a material during construction because of a lack of fines should not necessarily provide an excuse for mixing in a clay binder.



A pug mill machine is a continuous mixer commonly used for obtaining a dense, well-graded, uniformly mixed material.

Chemical stabilisation

Chemical products are often used to stabilise material when mechanical methods of stabilisation are inadequate or when replacing an undesirable material with a desirable material is not possible or is too costly. Nearly all chemical stabilisers fall into one of the following categories

- cement
- lime
- bituminous materials.

Collectively, these materials are usually referred to as binders. In Australia, most binders used for stabilisation are in a powder form, with bitumen being the main liquid binder. Sometimes additives are used with binders to enhance the construction process or provide additional long term properties to the stabilised material.

When selecting a binder, consider the following factors

- type of material to be stabilised
- purpose for which the stabilised layer will be used
- level of material quality improvement desired
- required strength and durability of the stabilised layer
- cost
- environmental conditions.

A 'modified' material will typically incorporate a small amount of a binding agent such as lime, whereas a 'stabilised' material will incorporate a larger amount of binding agents such as cement, fly ash or slag, alone or in combination. There is no internationally recognised and consistent definition which clearly establishes the difference between a 'modified' material and a 'stabilised' material. Typically, a 'modified' material will have a Unified Compressive Strength (UCS) of less than 1 MPa and a 'stabilised' material will have a UCS of above 1 MPa.

The decision to modify or stabilise a material is the choice of the designer and is usually based on local experience.

A material safety data sheet (MSDS) should be obtained for the stabilising material before use.

The permeability characteristics of the stabilised material can be altered. Permeability can be affected by the mixing method (wet or dry), the type and amount of binder, the time after mixing and the initial characteristics of the original material. For example, the addition of lime to a clay soil flocculates the clay soil particles and increases the permeability, whereas the addition of Portland cement reduces the soil's natural permeability.

Cement

A wide range of cement and cement blends can be used as an effective stabiliser for a wide range of materials and situations. Cement blends are effective stabilising binders and can affect material behaviour by

- greatly reducing the moisture susceptibility of some soils, giving enhanced volume and strength stability under variable moisture conditions



Spreader truck used for spreading dry binder agent onto base material.

- causing the development of interparticle bonds in granular materials, increasing the tensile strength and stiffness of the stabilised material.

There is a range of commercially produced cement types and blends, each with different properties and characteristics. The principal cement types available are

- Type GP – general purpose Portland cement
- Type GB – general purpose blended cement

GP cements are produced from a mixture of calcium carbonate, alumina, silica and iron oxide which, when calcined and sintered at high temperatures, gives a new group of chemical compounds capable of reacting with water. The composition of individual cements can vary depending on the nature and composition of the raw materials being used.

GB cements contain a combination of Portland cement with additives such as lime, fly ash, aslag (ground granulated blast furnace slag) and silica fume.

Blends are now preferred because they have

- slower setting times, resulting in a stronger final material
- longer working time
- greatly reduced chance of cracking

They also use recycled products and so are better for the environment.

Not all blends are available in all locations in Australia.

If the temperature during construction is less than about 5°C, the necessary chemical reactions are slower and the strength gain of the cement-material mixture will be minimal. Cement-material mixtures should be scheduled for construction during climatic conditions that will allow sufficient durability to be achieved, or another stabiliser should be considered for use.

Heavy vehicles should not be allowed on the cement-stabilised material before a 10–14-day curing period to prevent damage.

Portland cement can be used either to modify and improve the quality of the material or to transform the material into a cemented mass, which significantly increases its strength and durability. The amount of cement additive depends on whether the material is to be modified or stabilised, and can range from less than 4% to 16% of the dry weight of soil.

Water for cement stabilisation should be clean, free from organic material and contain less than 0.05% sulphates. The water source for curing cement stabilised materials should also be assessed; saline water can cause a build up of surface salts which can interfere with the adhesion of future seal coats.

Finely-graded gravels, clayey gravels, silty sands (>50% passing 425 µm sieve) and other materials without significant particle interlock are not suitable for use with cement binders. The life of these materials will generally be short and the surface will rapidly disintegrate with the onset of cracking.



Spreader truck spreading dry binder agent onto base material.

Lime

Lime reacts with medium, moderately fine and fine-grained materials to decrease plasticity, increase workability and strength and reduce swelling. Lime is used as a stabiliser for plastic materials whose plasticity indices generally exceed 10. For example, soils classified according to the USCS as CH, CL, MH, ML, SC, SM, GC, and GM should be considered as potentially capable of being stabilised with lime.

Lime can be used either to modify some of the physical properties of a material and thereby improve its quality, or to transform a material into a stabilised mass which then increases its strength and durability. The amount of lime additive depends on whether the material is to be modified or stabilised.

Hydrated or quicklime can be used. Most stabilisation is done using hydrated lime, but quicklime is more effective if the clay has to be dried before compaction. The chosen technique should be based on considerations such as contractor experience, equipment availability, location of site and availability of an adequate nearby water source.

Fly ash

Fly ash is a pozzolanic material that consists mainly of silicon and aluminium compounds that, when mixed with lime and water, forms a hardened cement-like mass capable of obtaining high compression strengths.

Fly ash is a product of the power generation industry. The type of coal used and the mode of operation of the power plant determine the chemical composition and particle size distribution of the fly ash. Consequently, not all fly ashes are suitable for use as stabilisers. Generally, fly ash derived from burning black coal is high in silica and alumina and low in calcium and carbon, and is well suited for use as a stabiliser. On the other hand, fly ash derived from burning brown coal contains large percentages of calcium and magnesium sulphates and chlorides and other soluble salts, which make it unsuitable as a stabiliser.

Unburned organic carbon breaks the continuity of contact in the cement-like reactions and should be limited to about 10%.

Fly ash used as a stabiliser should conform to AS 3582.1.

A stabilised feedlot surface constructed with a mixture of soil and 15–25% coal combustion fly ash offers the benefits of a very stable surface with relatively low material and construction costs (Anderson et al., 2004)

Before using this process for stabilising feedlot pen surfaces, all organic material, such as topsoil or manure, should be removed from the area.

Fly ash may be mixed externally and then placed on the pen surface, or it can be spread evenly over the loose pen surface and mixed using a set of discs pulled by a tractor. The material should 'roll' off the disc when it is adequately mixed. Moisture may be added to the fly ash during incorporation to minimise dust.

After the final pass of the mixing equipment, the blended material should be compacted to achieve maximum stabilisation. This is best



Large reclaimers/stabilisers for mixing binder agent into base material

accomplished with a sheepsfoot roller or the tyres of the placement equipment. The stabilised area should be maintained in a moist condition for approximately 5 days and then left for another 5 days before use.

Bituminous materials

Types of bituminous stabilisation are

- soil bitumen – soil cohesive is made water-resistant by admixture
- sand bitumen – sand is cemented together by bituminous material
- oiled earth – unsealed roads made resistant to water absorption and abrasion by spraying slow or medium-curing grade bitumen
- bitumen-waterproofed, mechanically stabilised material – two or more materials are blended to produce a good gradation of particles from coarse to fine. Comparatively small amounts of bitumen are then added, and the material is compacted
- bitumen-lime blend – small percentages of lime are blended with fine-grained materials to facilitate the penetration and mixing of bitumen.

The type of bitumen to be used depends on the type of material to be stabilised, the method of construction and the weather conditions.

Most bituminous stabilisation is performed in situ with the bitumen being applied directly on the subgrade and/or surfacing materials before immediate mixing and compaction. This type of construction used liquid asphalts (emulsions).

Polymeric stabilisers

Polymers act to repel the moisture from the fines in a host material and thus preserve the dry strength of the material; they are most responsive in soils or gravels containing over 10% silt or clay fines. The process involves the creation of a water-repellent soil matrix between the stones, which reduces permeability and so limits water ingress. By repelling moisture, the characteristics of the dry material can be maintained through soaked conditions. Because the polymer is so strongly attracted to clay, silt and soil particles it competes successfully with water to coat them, and so the softening and lubricating effect of any moisture that does enter the pavement is greatly reduced. This is referred to as 'internal' waterproofing of the fine-grained particles.

Unlike cement blends, polymers do not significantly increase the dry strength of the material. Hence Unconfined Compressive Strength (UCS) testing is not considered appropriate for investigating the benefits of polymer stabilisation. Polymer-modified material will typically have the same rigidity as the dry natural material; however, by keeping the water out of the material, it achieves greatly increased soaked CBR values and some increase in soaked UCS strengths.

In unsealed roads, stabilisation of materials with polymers reduces the potential for rutting after periods of wet conditions.





Stabiliser machine mixing binder agent into road base material. The mixed material is being compacted immediately by the sheepsfoot compacters.

Suitability of additive to soil type

Construction specifications usually specify two items. Firstly what binder to use and secondly, how much of it. Table 1 provides a broad guide as to the suitability of various binders to various host materials.

Table 1. Suitability of binder of soil type

Binder	Crushed rock	Well-graded gravel	Silty/clayey gravel	Sand	Sandy/silty clays	Heavy clays
Cement	Usually very suitable	Usually very suitable	Usually very suitable	Usually very suitable	Usually very suitable	Usually very suitable
GB Cement	Usually very suitable	Usually very suitable	Usually very suitable	Usually very suitable	Usually very suitable	Usually very suitable
Cement blends	Usually very suitable	Usually very suitable	Usually very suitable	Usually very suitable	Usually very suitable	Usually very suitable
Lime	Usually very suitable	Usually very suitable	Usually very suitable	Usually very suitable	Usually very suitable	Usually very suitable
Lime and cement	Usually very suitable	Usually very suitable	Usually very suitable	Usually very suitable	Usually very suitable	Usually very suitable
Lime and fly ash	Usually very suitable	Usually very suitable	Usually very suitable	Usually very suitable	Usually very suitable	Usually very suitable
Bitumen	Usually very suitable	Usually very suitable	Usually very suitable	Usually very suitable	Usually very suitable	Usually very suitable
Bitumen/cement blends	Usually very suitable	Usually very suitable	Usually very suitable	Usually very suitable	Usually very suitable	Usually very suitable
Insoluble polymers	Usually very suitable	Usually very suitable	Usually very suitable	Usually very suitable	Usually very suitable	Usually very suitable

Usually very suitable 
 Usually satisfactory 
 Usually not suitable 

Construction considerations

Successful stabilisation using any additive requires the use of purpose-built spreading and mixing equipment.

When materials are required to be stabilised, the stabiliser binder is either dry spread with spreader trucks followed by the use of a stabilising machine, or fed through a dedicated mixing plant (pug mill). Within these plants, the granular material is fed into a mixing chamber where water and binders are added in a set sequence to allow uniform dispersion of moisture and binding additives. The even mixing and distribution of the binders is important to the ongoing performance of the pen and/or road surface. The amount of stabilising binders added can be based on the percentage either by weight or volume, depending on the equipment used. Mixing should not be attempted with other earthmoving or paving equipment.

The spreaders should be enclosed protecting the additive from the weather, and have accurate, variable distribution mechanism.

Stabilised materials must be compacted immediately after spreading in order to obtain their optimum strength and performance.

Specification compliance

The design performance of stabilised materials is not measured by the percentage of binder added to the material, but rather by separate testing of the material to determine its Unconfined Compressive Strength (UCS).



Stabiliser machine mixing binder agent into road base material.

The UCS involves the compaction of the stabilised surface material at the correct moisture content, curing and crushing under controlled laboratory conditions, and thus provides a repeatable measure of the compressive strength of the material.

Specification compliance often requires a modified or stabilised material to achieve a minimum UCS value. As pen and road surface materials can be produced from many geological types from various sources, the required UCS may be achievable with a low percentage of binder for one material, but need a significantly higher percentage for another. For this reason, compliance is normally measured not on the percentage of binder added, but by the achievement of the UCS test.

Quick tips

- In-situ material may have low load-bearing strength because of an excess of clay, silt or fine sand. Stabilisation can be used to achieve the design specification at a much lower cost than importing the correct material.
- Material may be stabilised to increase strength and durability or to prevent erosion and dust generation.
- Do not confuse material binders and dust suppressants. Dust suppressants provide short-term solutions to reduce the generation of dust from pens and/or roads and are not typically mixed with the surface materials.
- Seek specialist advice if stabilisation is being considered.
- Poor trafficability or compaction of a material during construction should not necessarily provide an excuse for adopting material stabilisation.
- Normal basic material parameters such as MDD, OMC, grading and PI should be determined on the in-situ material to aid the selection of the most appropriate binder.
- Binders are admixtures used for chemical stabilisation.
- Pen and road surfacing specifications should specify what binder and how much to use.
- Lime is used to modify plasticity properties of high plastic clays to increase workability and strength.
- Cement-like binders give best results with low plasticity materials (e.g. gravels).
- Not all fly ash is suitable as a stabilising agent.
- In modified or stabilised materials the clock is ticking from the time cement binders touch water in the mixing chamber of the mixing plant. The time of hydration is the time available to apply it to the surface and compact it.

Further reading

National Association of Australia State Road Authorities 1970, Guide to Stabilisation in Roadworks, National Association of Australia State Road Authorities.

Anderson, V, Buckley, T, Pflughoeft-Hassett, D and Stewart A, 2004, Instructions for Use of Fly Ash to Stabilize Soil in Livestock Facilities – AS1258, North Dakota State University ND Agricultural Experiment Station Carrington Research Extension Center.

Austrroads (2006) Guide to Pavement Technology Part 4(d): Stabilised Materials Austrroads Project No: TP1089, Sydney, NSW.

AustStab (2006) Lime Stabilisation Practice AustStab Technical Guideline, Australian Stabilisation Industry Association, Chatswood, NSW.

AustStab Technical Note No. 5 Cement Stabilisation Practice.

Parker, DB Mehlhorn, JE, Brown, MS, and Bressler SC, 2004, Engineering Properties and Economics of Soil Cement Feedyard Surfacing. Transactions of the ASAE, Vol. 47(5): 1645–1649, American Society of Agricultural Engineers ISSN 0001–2351.

Rodway, B and Wilmot, T (1999) Selecting the Additive Cementitious, Polymer or Bitumen Proc. 10th National Local Government Engineering Conference, Sydney.

Rodway, B (2001) Polymer Stabilisation of Clayey Gravels Proc. 20th ARRB Conf. Melbourne.

Ingles, OG and Metcalf, JB, 1972, Soil Stabilisation – Principles and Practice. Butterworths.



FEEDLOT DESIGN AND CONSTRUCTION

19. Feeding systems

AUTHORS: Peter Watts, Mairead Luttrell and Orla Keane

Introduction

The feeding system must be well designed to achieve good cattle performance, efficient feedlot operation and for maintaining high environmental standards.

Design objectives

Feeding systems should

- provide livestock with free and continual access to feed
- maintain fresh and palatable feed
- minimise waste, spilled feed and spoilage
- prevent all classes of cattle from fouling the feed and escaping from the pens
- allow easy delivery of feed
- allow for easy cleaning and removal of spoiled feed after rainfall
- not inhibit pen cleaning
- minimise environmental impacts (odour, flies, dust)
- minimise ongoing maintenance costs
- provide a safe working environment for pen riders and other feedlot personnel.

Mandatory requirements

Compliance with

- Australian Animal Standards and Guidelines for Cattle (DAFF, 2013).
- National Guidelines for Beef Cattle Feedlots in Australia (MLA, 2012a).
- National Beef Cattle Feedlot Environmental Code of Practice (MLA, 2012b).
- NFAS standards (AUS-MEAT, 2011).

Design choices

The feeding system can use either self-feeder bins or open feed bunks.

Self-feeders

Self-feeders are best suited to small and/or opportunity feedlots which do not prepare their own rations or where rations are milled and mixed off site.

Advantages of self-feeders include that they

- have their own storage bins and so need filling only once or twice a week
- are readily transportable, can be installed quickly, can be used as a temporary feed-out system
- can be used elsewhere on the farm or in a small paddock or yard to form a temporary feedlot for drought feeding
- can be moved around within pens.



Self-feeder in a feedlot. The open area under the self feeder allows buildup of manure, odour and flies, and in wet weather it can become boggy. The feed truck has to enter the pen to deliver feed.

Problems with self-feeders in feedlots include

- Rations that are moist, contain large amounts of roughage (particularly coarse roughage) or contain molasses or oils may bridge and restrict feed supply.
- If a self-feeder bridges or is allowed to empty completely, cattle are likely to gorge on feed when it is delivered. This can result in acidosis and deaths.
- Hay racks often need to be used with self-feeders, particularly during the introductory feeding phase.
- Moist feeds tend to ‘go off’ or spoil when stored in self-feeders for several days.
- Manure and spilt feed accumulate under the feeder generating odour and fly breeding sites, unless the feeder is designed well and the area cleaned frequently.
- Self-feeders must be located so that they can be filled during all weather conditions, preferably from outside the pens. This is possible only where the feed trough is on one side and they can be placed parallel to and up against the top fence.
- Self-feeders with feed troughs on both sides must be placed at right angles to the top fence and are therefore more difficult to fill from outside the pens.
- They should be located at the top side of pens so that they have minimal impact on pen drainage.

The size and number of self-feeders depends on the number and estimated feed intake of cattle being fed, the frequency of filling and the type of ration. Self-feeders typically have capacities of 3.5 tonne, 5.5 tonne and 7.5 tonne. Based on an average dry matter intake (DMI) of 12 kg DM/head/day and a moisture content of 12%, the as-fed intake would be about 13.4 kg/head/day. Table 1 calculates the number of self-feeders needed for pens of different capacity.

Table 1. Number of self feeders/pen for weekly feeding

Self feeder capacity (kg)	SCU/pen		
	100	150	200
	No. of self feeders		
3500	3	5	6
5500	2	3	4
7500	2	2	3

Feed bunks and aprons

Most commercial feedlots use open feed bunks (troughs). They generally process their own feed and can feed-out more than once a day. All types of rations, including those moist or containing large amounts of coarsely chopped fibre, can be fed in troughs.

Location

Feed bunks should always be located along the fence line, never within the pen, so that they can be filled during all weather conditions. They should be located along the higher end of the pen with drainage away from the bunk on both the feed road and pen sides. This minimises boggy conditions on the pen side of the bunk and keeps the feed road firm and accessible.



One-sided self-feeders placed on a fence line and filled without entering the pen. A concrete apron is provided for stability, but manure can still accumulate under the self feeder and will need to be removed regularly.



A two-sided self-feeder placed on a concrete apron and close to the fence line so that it can be filled from outside the pen.



Access gate at the top end of the pens



Posts cast into the concrete wall need to be treated with epoxy to prevent corrosion at the concrete joint.



A rusted or broken post has been replaced with a new post bolted to the back of the wall.

Bunk length

The length of a bunk depends on the number of cattle in the pen and the dimensions of the pen. Bunks usually run the entire length of the pen although some feedlots provide access gates in the top end of their pens. The type of feed ration (bulkiness), size of the cattle and desired feeding frequency must also be considered.

Bunk length per head

Most lot feeders would require 250 mm to 300 mm per head of bunk space.

The temptation to design for 200 mm of bunk space per head in order to minimise building costs may be false economy if 50 or 100 mm extra space would enhance cattle performance.

A shorter bunk space may restrict the opportunity of shy feeders to feed, particularly during the introductory phase. In these cases, some cattle will take longer to adapt to the high energy ration, there may be more cases of acidosis, less uniform finishing of cattle within pens and lower average daily weight gain of cattle within the pen.

Fence posts

Fence posts along the feed bunk may be cast into the bunk itself (for bunks that are cast on site), located against the vertical wall of the bunk on the pen side or on the inside of the feed bunk (for either pre-cast or cast on site). The posts can be built into a feed bunk wall of uniform thickness or with a locally thickened wall around the post.

A feed bunk wall of uniform thickness will make it easier to remove accumulated waste but the wall must be thicker to prevent it from cracking or from damage during pen cleaning; this will add substantially to the capital cost.

Local thickening of concrete around the posts, or having the posts on the outside of the feed bunk, will make it difficult to clean around them to remove manure that has built up against the bunk wall and to clean along the feed trough apron. Posts that are cast into the concrete wall need to be treated with epoxy or equivalent to prevent corrosion at the steel/concrete joint and subsequent failure.

All steel posts need to be capped top and bottom to prevent water entry and subsequent rusting. Top rails are highly recommended along feed trough posts as these help to strengthen the whole feed-bunk fence system which is continually being pushed by feeding cattle. An expansion joint every 25 m in long cattle rails will prevent buckling.

Restraint devices

Cattle must be prevented from entering the feed bunk and possibly escaping. This has been achieved using a system of cables strung out over the feed bunk, but this can make it difficult to maintain and clean the trough. In most modern feedlots, cattle are constrained by the design of the feed bunk back wall and a single cattle rail.

An adjustable height cable below the cattle rail or an adjustable rail will restrain a range of cattle sizes in a pen.

The judicious use of an electric wire adjacent the cattle rail or top cable can help teach cattle not to press against the restraint system.

Cross-sectional dimensions

The cross-sectional area of the trough determines the amount of feed that can fit into the trough per unit length. If the cross-sectional area is too small frequent filling will be necessary, particularly if silage or other bulky ingredients are fed. If the feed bunk is too wide, feed pushed to the back of the bunk is less accessible and cattle are tempted to step into the trough to try to reach it.

Feed bunks should have vertical external faces on either side for ease of removing built-up manure and spilt grain. Outwardly sloping sides make wastes trapped around them difficult to remove, but may reduce damage by the feed truck.

The inside of the feed bunks should be smooth with rounded corners. Square inner corners will trap inaccessible feed allowing it to become mouldy or stale, and are also difficult to clean.

Feed bunks should allow rainwater to drain, preferably by having drain holes or slots at intervals along the length of the trough. These drainage points need to be large enough that they do not get blocked. Water can also drain if a shorter feed bunk is left open at the end. Adequate slope (>1%) longitudinally along the feed road and bunk enhances drainage after storms.

Feed bunks must be designed for easy filling. They should be readily fillable from the feed road side without opening and closing gates. Feed alleys should be straight and not curved to minimise spillages and damage by the feed truck; the approach should have a straight section so the truck is moving parallel to the trough when unloading.

Over the years, a wide range of different feed bunk dimensions have been used.

Table 2 gives the dimensions of several different types. Important dimensions are

H1 – the height of the back wall above the feed apron. This should be 500 mm high to prevent cattle stepping into the feed bunk.

H2 – the height of the front wall above the feed road. This needs to be higher than the back wall but not so high that it interferes with feed delivery. Experience indicates that this should be 700–750 mm high.

H3 – the height of the cattle restraint rail above the apron. In conjunction with H1, these dimensions allow cattle free access to feed without rubbing or awkward bending but prevent cattle from stepping out of the pen into the trough. H3 should be lower for smaller cattle and therefore a restraint system where H3 can be varied is desirable. Typically, H3 should be about 1000–1150 mm above the feed apron.

W1 – the width of the feed storage area of the bunk. In conjunction with other dimensions, it determines the volume of feed that can be held. If W1 is too large, cattle cannot reach feed without straining.

W2 and W3 – the thicknesses of the front and back walls. Greater thickness provides more bunk strength but adds to the volume and cost of concrete required.

A1 – the cross-sectional area of feed per metre length of bunk. The Type D bunk is an old design that provided only 0.15 m² of feed, and has been found to be inadequate. Newer bunks provide over 0.2 m² of feed per unit length, which is 30% more than Type D.



Expansion joints prevent buckling of steel cattle restraint in hot weather.



Drainage points along the feed bunk must be large enough so they do not become blocked.

A2 – the cross-sectional area of concrete for the bunk. This dimension has a large bearing on capital cost. The old Type D trough has less than half of the concrete per unit length than the new bunk, but this is at the expense of feed volume and cattle constraint.

Table 2. Sample feed bunk dimensions

Type	H1 mm	H2 mm	H3 mm	W1 mm	W2 mm	W3 mm	A1 m ²	A2 m ²	A1/A2 Ratio
A	500	545	1080	715	135	120	0.196	0.219	0.89
B	610	790	1140	825	150	100	0.266	0.409	0.65
C	575	625	1190	662	75	70	0.183	0.187	0.98
D	429	550	1100	590	100	90	0.150	0.159	0.94
E	519	619	1110	790	100	90	0.219	0.240	0.91
F	480	750	1080	840	160	100	0.164	0.386	0.42
G	480	760	1000	780	140	70	0.162	0.347	0.47
H	550	725	1155	715	125	125	0.221	0.239	0.92



A large bullock feeding from a Type A feed bunk

The following sections show most of these sample feed bunks.

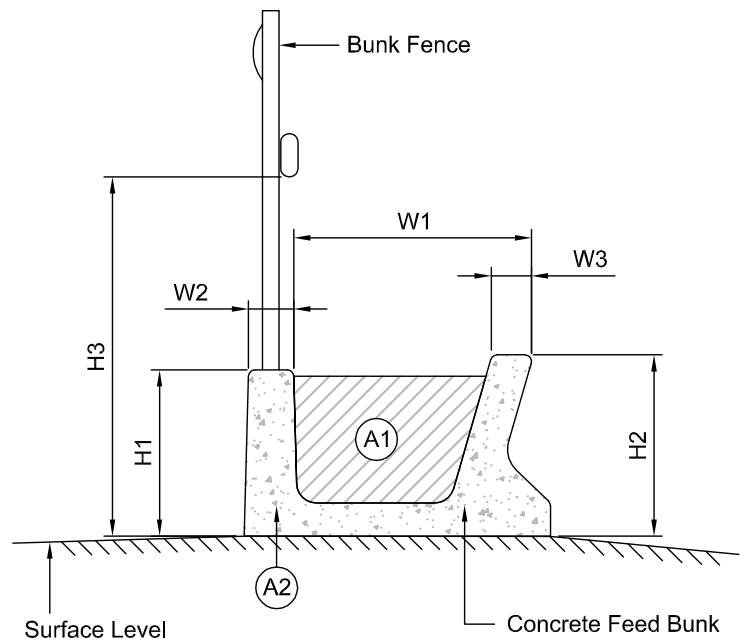

Feed bunk Type A

The projection of concrete at the base of the bunk front wall (feed road) was designed to prevent feed trucks from pushing against the front wall.

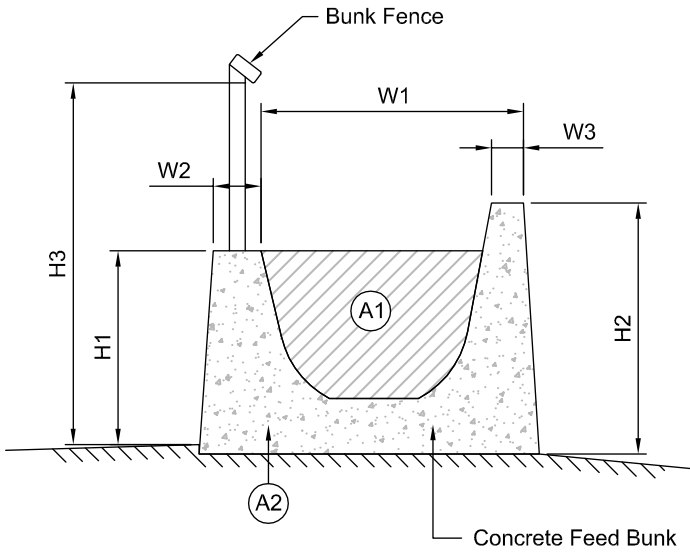

Feed bunk Type B

The inward slant from the base to the top of the front wall (feed road side) of the bunk was designed to prevent feed trucks from pushing against the front wall. The sloping back wall also reduces damage from pen cleaning equipment.

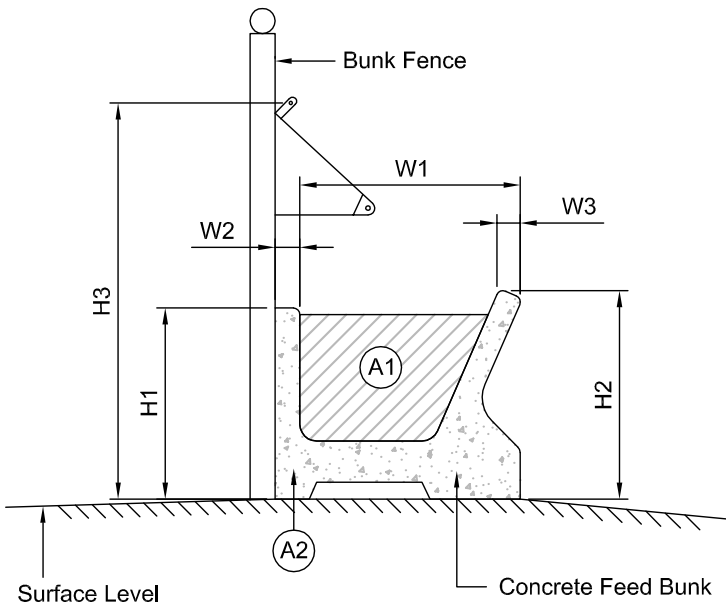

Feed bunk Type C

A pre-cast feed bunk available in 2.4 m lengths. This cross section has a high ratio of feed area to concrete area.



Individual pre-cast section feed bunk Type C. This cable arrangement makes trough cleaning more difficult; a single rail is usually sufficient to confine cattle.



Feed Bunk Type D
An old design with a cross-sectional area that does not hold enough feed, and the back wall is too low.

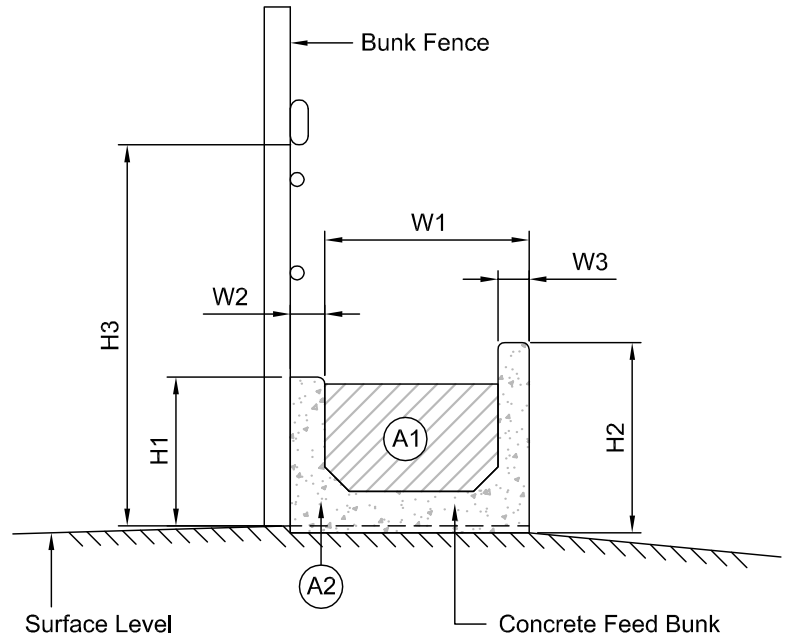

Feed bunk Type D

This old design minimises the volume of concrete for the feed bunk. The planar internal sides and bottom make cleaning by shovels easier.

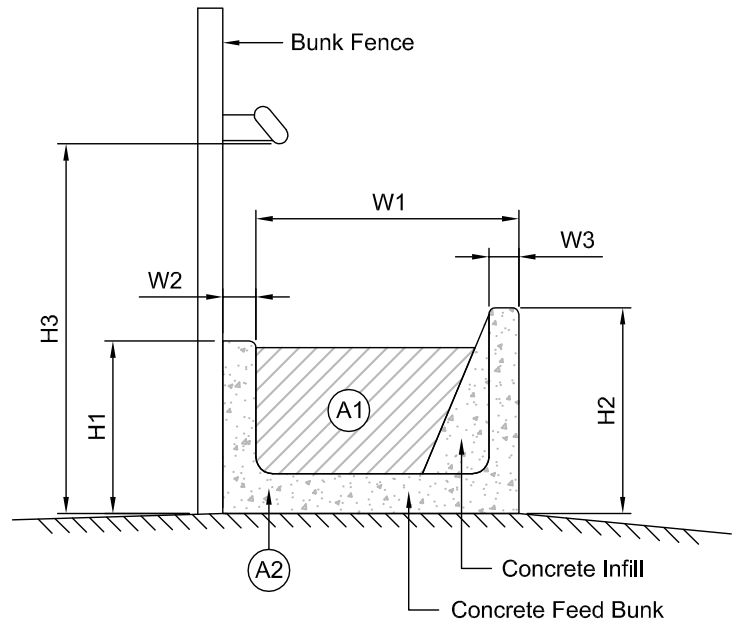

Feed bunk Type E

Type E has a vertical front wall (road side) and concrete infill, but offers few advantages over alternative designs.

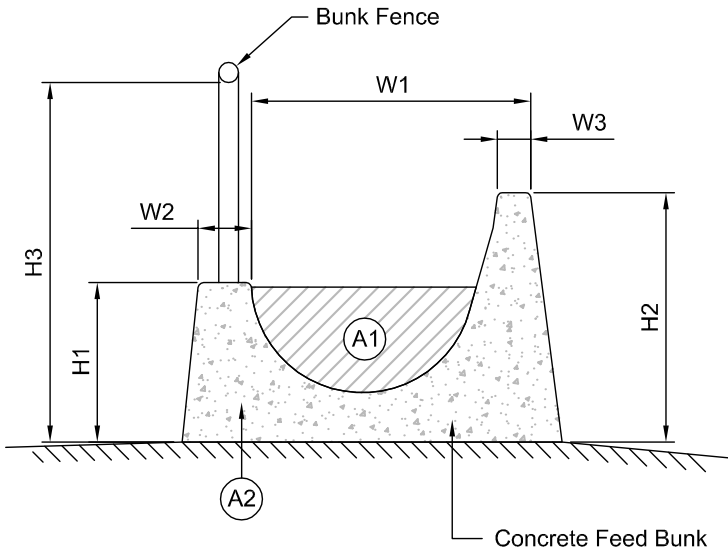

Feed bunk Type F on top of concrete apron.

Feed Bunk Type F

Type F is solid and robust. The inward sloping front and back walls are designed to minimise damage by feed trucks and pen cleaning equipment from pushing against the walls. The round bunk shape enables cleaning by rotary brooms.

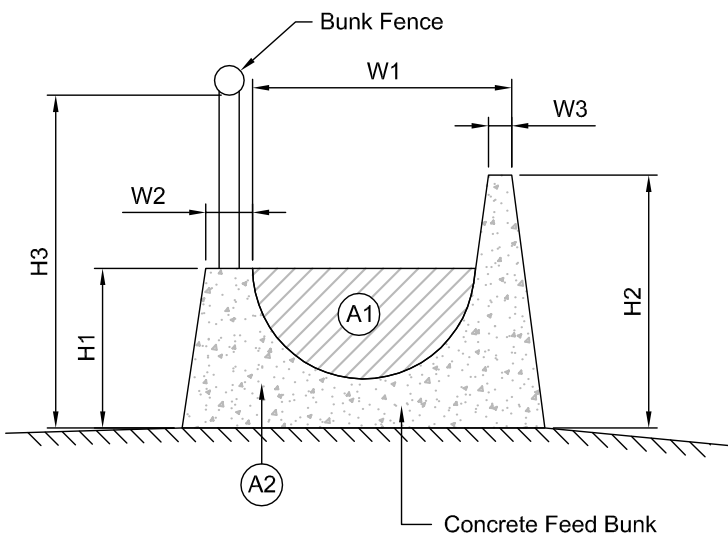

Feed Bunk Type G on concrete apron. Front wall slopes towards the pen.

Feed Bunk Type G

Type G has a similar profile to Bunk F but is narrower. The inward sloping front wall is designed to minimise damage by feed trucks from pushing against the front wall. The round feed bunk shape enables cleaning by rotary brooms.



Feed Bunk type H cast in situ.

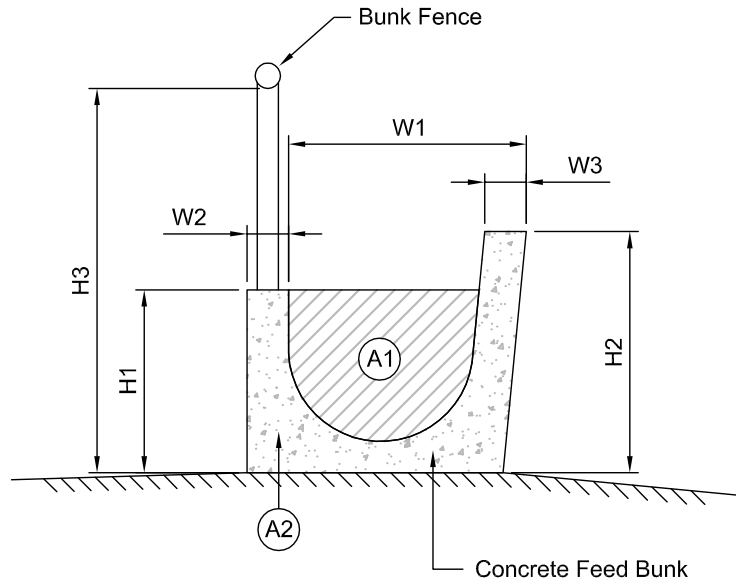

Feed Bunk Type H

The outward sloping wall on the feed road side should minimise feed spillage from feed truck but may get damaged by truck and cleaning equipment.

Bunk problems



Bends in the road and the feed bunk require extra skill from the truck driver to avoid feed spillage.



Without suitable anchoring, pre-cast bunk sections can be moved out of alignment.

Bunk aprons



Concrete apron on the pen side of the bunk provides a stable base against mud holes, and allows easy cleaning.



A concrete apron extending onto the feed road will reduce any impact on the feed truck load cells and give more control on feed delivery. The apron should slope gently away from the bunk, but still allow the truck driver to see into the bunk.

Posts in back wall



Local thickening of the feed bunk wall is strong but may make cleaning difficult.



Posts cast into the bunk back wall of the feed bunk can rust at the joint between the post and the back wall. Replacement posts bolted inside of the bunk could inhibit bunk cleaning.

Posts behind back wall



Cable systems above feed bunks can inhibit bunk cleaning.



Posts bolted behind the back wall are more readily replaced but can hinder cleaning along the feed apron.



External posts of old cheap railway line will inhibit cleaning along the feed apron and lead to damaged posts and bunks.



Intruding posts will make apron cleaning difficult.



Damage to the ends of feed bunks by feed trucks will be minimised with a straight feed road and placing a steel bollard.

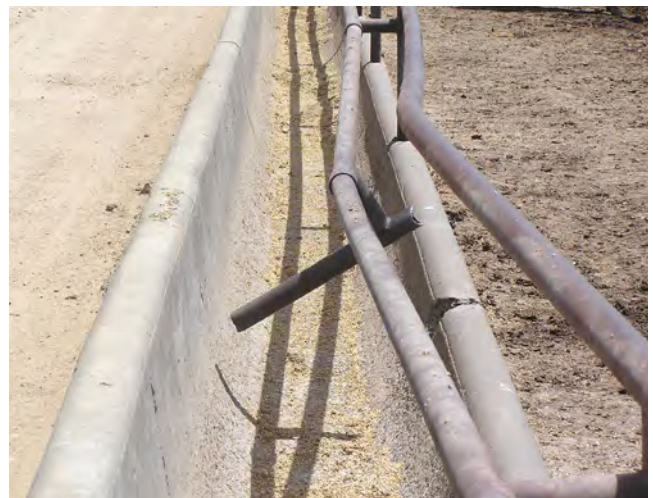

Posts cast into the back wall can corrode and be damaged.

Cattle restraint



A fixed, two-bar cattle restraint



Single steel bar cattle restraint with posts cast into the back wall of the feed bunk



Cattle restraint using only cables. The lower cable can be adjusted to suit different sizes of cattle



The lower cable indicates that the back of the feed bunk is too low while the top cable is redundant

Trough cleaning

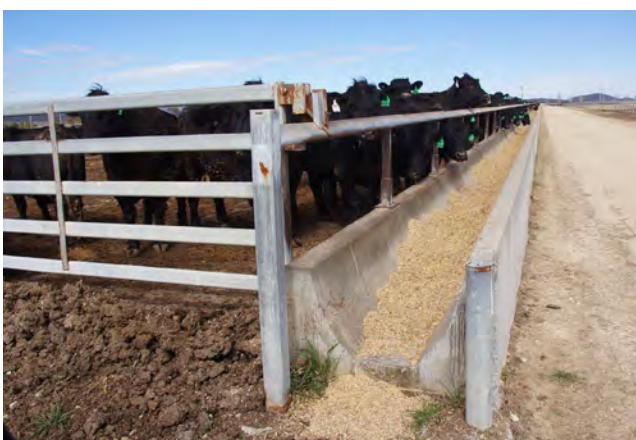

Feed Bunk type F with steel posts bolted to the top and rear of the back wall, with a single-bar cattle restraint. A steel bollard prevents damage to the end of the feed bunk.



Feed trough made from rubber belting is difficult to clean internally and externally. Manure and spilt feed promote odour, flies and vermin.



Bunk of corrugated steel half-pipe inside which rubber belting has been subsequently laid. Same issues as above.



Finished concrete surface of feed bunk should be sprayed with curing oil immediately to minimise shrinkage and cracking.

Feed bunk covers

Fixed covers over feed bunks are generally not recommended. While a fixed roof over the feed trough protects feed from weather, keeping it dry and palatable, it does promote management problems. Regardless of weather conditions, cattle seem to stay under the shade near the feed trough throughout most of the day, and waste builds up around it. Also, cattle resting in the shaded area can limit access of shy feeders to the bunk; this will limit the performance of these cattle and result in uneven finishing of the cattle within the pen. In Australia, a cover over the feed bunks would be desirable only at a site with heavy annual rainfall—not a preferred location for a feedlot.

Construction materials

Feed bunks have been made from concrete, fibreglass, rubber belting, steel and wood. All commercial feedlots now have concrete feed bunks and the use of other materials is not recommended.

Concrete feed bunks are either pre-cast or poured on site. Pre-cast bunk segments come in various lengths (usually 2.4 m) and these have always to be kept aligned. Misaligned rows of pre-cast feed bunks due to differential settling of the foundations or impact from feed trucks allows grain to spill and makes it difficult to clean up spilt grain and built-up manure. Pre-cast bunks are best placed on a concrete strip for a more stable bunk structure.

Half-pipe segments are sometimes used as feed bunks but should be avoided, since they allow waste to build up under the trough and this is almost impossible to remove mechanically.

Pouring feed bunks on site in one long run keeps them permanently aligned, and they can be built to specified dimensions by developing a special mould.

The concrete used to build feed bunks should be high quality and strength (20 MPa or better). Fibre reinforced concrete is used, as steel reinforcement is difficult to place.

Surface protection and repair

Some ration ingredients, particularly silage and molasses, will corrode steel and iron in concrete reinforcement, and concrete surfaces. Sealing the inside of the feed bunk with two-component epoxy resin will protect the surface from chemical attack and abrasion.

As with all coating applications, surface preparation is critical. Epoxy is best applied when the bunk is new. The surface must be dry and free of dust and surface contaminants (such as oils or chemicals) before application.

Typically, two or more coatings will be required, and this protection will need to be renewed periodically as the original surface wears.

Construction techniques for slip-form feed bunks

Slip forming, continuous poured, continuously formed, or slip-form construction is a construction method in which concrete is poured into a continuously moving form. Slip forming enables continuous, non-interrupted, cast-in-place 'flawless' (i.e. no joints) concrete bunks which have superior performance characteristics to pre-cast bunks.

Subgrade preparation

Before placing the slip form, the foundation material needs to be shaped and compacted to form a firm base, or a concrete base can be used. An uneven surface uses more concrete and leads to uneven feed bunks. The feed apron and base can be cast in preparation for slip-form construction.

Consistency and additives

A balance between quick-setting capacity and workability is required. Concrete needs to be workable enough to be placed into the form and compacted, yet quick-setting enough to emerge from the form with strength. Just enough water needs to be added to chemically complete the hydration process with virtually no slumping. At all times between mixing and discharge the slump should be within the range specified for the nominated mix.

Concrete which is non-conforming in relation to consistency should not be incorporated into the work.

Traditional mesh reinforcement in construction of feed bunks is difficult due to their size and shape. The use of synthetic/steel fibres in the concrete mix provides benefits for the concrete while it is still plastic and in the hardened concrete.

Synthetic fibres are most commonly added to concrete for slip-form construction to reduce early plastic shrinkage and long-term cracking while increasing impact and abrasion resistance and toughness of the hardened concrete.

Table 3. Example of concrete mix design for slip form bunks

Constituent	kg/m ³
Aggregate	970–1100
Sand	820–970
Cement	330–350
Water	80–95
Additives – synthetic/steel fibres	0.1% by volume approx. 0.9kg/m ³

Construction tolerances

The finished surface of the feed bunk should be uniform in appearance and comply with the practical design tolerances and client expectations.

Jointing

Contraction joints should be formed at 6 m centres.

Trial section

The construction of a trial section of bunk is highly recommended. This will ensure that equipment, concrete mix, contractors and techniques are able to demonstrate to the client the quality, finish and tolerance of the finished feed bunk, and gain approval from the client of a standard of workmanship that will be acceptable for ongoing feed bunk work. This section should then be used as a 'standard' for any future works to be compared against.

The trial section should be constructed using the same materials, concrete mix, equipment and methods the contractor intends to use



Sealing the inside of the feed bunk with epoxy resin will protect the surface from chemical attack and abrasion.



Good concrete mix with consistent moisture content is essential throughout the whole slip-form process—or problems will occur.



Feed Bunk G. The slip-form machine runs on prefixed rails, then the surface is steel trowelled.



A wide concrete apron allows cattle to stand comfortably while feeding.



Concrete aprons on pen and feed road sides

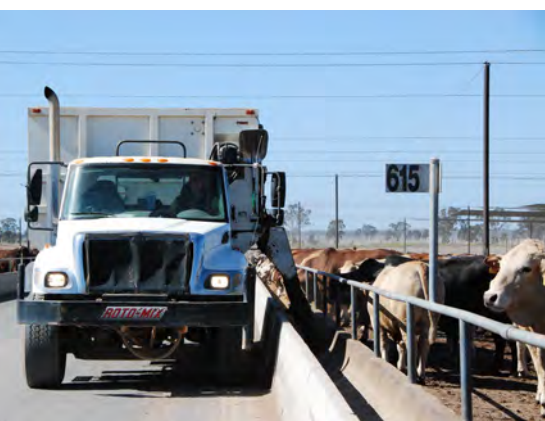

Feed delivery trucks usually feed out on the same side as the driver with left or right hand drive.

for the remaining work. The contractor needs to demonstrate the methods proposed to be used for texturing, the application of curing compound and construction of joints.

The trial should also be used to demonstrate that the contractor's allowances for concrete strength, compaction and slab thickness are adequate to achieve the minimum requirements specified.

Only after acceptance by the client of the trial section should the contractor proceed with placing concrete.

Selection of contractor

An experienced slip-form contractor and concrete supplier should be engaged. Slip-form systems require a small but highly skilled workforce on site.

Timing of construction

The quality of work will depend upon the weather conditions. It is best to avoid slip-form construction of feed bunks during the extreme heat conditions that commonly prevail during the summer months. Work should be programmed outside the summer months where possible.

Aprons

Without an apron, the pad near the bunks will wear and form bog holes. Aprons provide a stable surface for cattle to stand on and allow for easier removal of wastes.

Concrete or compacted gravel aprons should be 2.5–3.0 m wide, allowing pen cleaning machinery to fit along them. Wider aprons also minimise damage to the pad from cattle hooves.

Aprons should slope uniformly away from the trough at the same slope as the pen slope. Concrete aprons should be properly reinforced, and a moulded rough surface can reduce slippage by the cattle. Damage to the edge of the apron will be minimised by building a short rat baffle on the pen side of the apron.

Installing gates across the aprons at the top of each fence line allows pen cleaning machinery a smooth straight run, and allows pen riders to move more freely between pens.

A 1 m apron on the feed road side improves consistent feed delivery.

Feed delivery vehicles

Feed delivery vehicles may be self-propelled feed trucks or tractor-drawn wagons. As a guideline, allow one feed truck with a 5 t load capacity for each 7000 head in the feedlot. As any machine may suffer a breakdown, even a small feedlot should never rely on having only one feed truck. See *Section 35 – Feed mixing and delivery* for further information on feed delivery vehicles.

Feed-out trucks deliver feed only from one side, either left hand or right hand. This determines the direction of movement of the feed trucks when delivering feed to the bunk. To avoid spillage, the truck needs to be aligned straight with the bunk before and as the feed is delivered. This will require an adequate length of straight feed road leading onto a feed bunk section.

Feeding system maintenance

Bunk cleaning

Most feedlot cattle are fed once or twice a day with just enough ration put out to meet intake requirements. As a result, feed does not usually go stale, but any leftover feed should be removed on a daily basis. Rain can cause feed to become wet and unpalatable, and cattle may go off their feed during rainy or hot weather. In such cases, bunks must be cleaned – usually with brooms and shovels.

The rotary brush cleaners now available should be used to throw uneaten wet grain into the pen from where it can be removed during pen cleaning. Cables above a feed bunk can severely restrict feed bunk cleaning.

Bunk maintenance

Pre-fabricated or other segmented feed bunks may be bumped out of line by feed truck drivers from time to time. Feed bunks must be kept aligned lest feed spills out and to allow easy cleaning around the trough and along the aprons. Drainage gaps or holes clogged with feed must be cleaned.



Feed spoiled by rain is usually cleaned out manually with shovels. Access to the feed bunk must be open and clear.

Quick tips

- Self-feeders are suited best to small and/or opportunity feedlots.
- Self-feeders have their own storage bins and need filling only once or twice a week.
- Moist rations tend to ‘go off’ or spoil when stored in self-feeders for several days.
- Feed bunks should always be located along the high end of the pen along the fence line.
- Bunk space should be 250–300 mm per head in the pen.
- A bunk with a small cross-sectional area will require frequent filling, particularly with silage or other bulky ration ingredients.
- If feed bunks are too wide, feed can be pushed to the back of the bunk and cattle are tempted to step into the trough to try to reach it.
- Feed bunks should have enclosed vertical faces on either side for ease of removing built-up manure and spilt grain.
- The inside of the feed bunks should be smooth with rounded corners; square corners trap feed and are difficult to clean.
- Fence posts on the outside of the feed bunk make it difficult to remove manure build up along the bunk wall or to clean along the feed trough apron.
- Thicker front and back walls give a feed bunk greater strength and volume, but cost more.
- Feed bunks should have drain holes or slots at intervals along the length of the trough to drain rain water.
- Expansion joints in long cattle rails to prevent buckling.
- When the feed bunk is new, seal the inside with two-component epoxy resin to protect the surface from chemical attack and abrasion.

Further reading

AUS-MEAT, 2011, NFAS Rules & Standards (April 2011), AUS-MEAT Limited, Brisbane, Qld.

DAFF, 2013, Australian Animal Standards and Guidelines for Cattle, Department of Agriculture, Forestry and Fisheries, Australian Government, Canberra, ACT.

MLA, 2012a, National Guidelines for Beef Cattle Feedlots in Australia. Meat & Livestock Australia, Sydney, NSW.

MLA, 2012b National Beef Cattle Feedlot Environmental Code of Practice. Meat & Livestock Australia, Sydney, NSW.

Guidelines for the establishment and operation of cattle feedlots in South Australia, Department of Primary Industries and Resources (SA) and Environment Protection Authority, 2006, Adelaide.

Victorian code for cattle feedlots, August 1995, Victorian Feedlot Committee, Department of Agriculture, Energy & Minerals, Melbourne.

Skerman, A 2000, Reference manual for the establishment and operation of beef cattle feedlots in Queensland, Information Series QI99070, Queensland Cattle Feedlot Advisory Committee (FLAC), Department of Primary Industries, Toowoomba, QLD.

Guidelines for the Environmental Management of Beef Cattle Feedlots in Western Australia, Bulletin 4550, 2002, WADo Agriculture (ed.), Western Australia Department of Agriculture, Perth, WA.

The New South Wales Feedlot Manual, 1997, NSW Agriculture, NSW Agriculture, Department of Land and Water Conservation, Department of Urban Affairs and Planning & Environment Protection Authority, Orange.



FEEDLOT DESIGN AND CONSTRUCTION

20. Water trough design and sewer systems

AUTHORS: Rod Davis and Peter Watts

Introduction

Water troughs should allow cattle access to an adequate supply of good quality water for their survival, welfare and performance without causing negative environmental impacts for the feedlot.

Design objectives

The water trough system should

- provide a fresh, cool, clean, palatable and adequate volume of water to livestock
- provide sufficient access area to enable all cattle to drink regularly
- be strong, durable and resistant to damage from cattle and pen-cleaning equipment
- allow for easy and regular cleaning inside the trough
- allow for easy cleaning of the trough exterior with minimal obstruction during pen cleaning
- not allow manure to accumulate underneath or be a breeding area for flies or vermin
- allow for easy maintenance of pipe and drainage fittings
- not cause wet areas or drainage problems in pens or lead to pen maintenance issues.

Mandatory requirements

Compliance with

- Australian Animal Standards and Guidelines for Cattle (DAFF, 2013)
- National Guidelines for Beef Cattle Feedlots in Australia (MLA, 2012a)
- National Beef Cattle Feedlot Environmental Code of Practice (MLA, 2012b)
- NFAS standards (AUS-MEAT, 2014).

Technical requirements

The most suitable layout and dimensions of water troughs will be based on the volume of water per unit access length, the depth of trough, trough height, drainage point and position, side enclosure, float valve protection and on preventing cattle entering the troughs.

Capacity

The water delivery system and water trough volume must be adequate to meet the daily water requirements and peak demand of the cattle. Further information on cattle drinking water is provided in *Section 4 – Water requirements*.

The volume of water per unit access length must consider

- maximum flow rate of the reticulation system
- temperature of water in the trough
- volume of water flushed into the pens during cleaning.

The volume of water wasted into the pen with each flushing is minimised by using low-volume troughs; long, narrow, shallow troughs are preferable to large, deep, high-volume circular troughs.

Shape

Most feedlot troughs are rectangular rather than round as these fit along fence lines, are more easily cleaned internally and easier to clean around with machinery; they provide more linear space than an equivalent capacity round trough.

The internal cross section of trough is generally either a u-shaped or trapezoid (wider at the top than bottom) with varying degree of side angle.

Length

A minimum of 25 mm/head of linear trough space available should be provided during normal weather conditions and 75 mm/head during hot conditions (MLA, 2006). Available length is the trough length less the length unavailable due to float protection.

Materials

All materials should have a life expectancy of ten years or more. Common construction materials are reinforced concrete, polyethylene, fibreglass and steel.

Concrete is the most common material because it is more durable and can stabilise water temperature. Troughs can be cast on site but most are prefabricated units.

All designs should meet the industry standards for the material being used. Polyethylene or fibreglass water troughs should be made of ultraviolet resistant materials or have a durable coating to protect against deterioration under sunlight.

Surface coating

Over time, the inside surface of a concrete trough becomes difficult to clean as it deteriorates through hardness of the water, action of cattle licking, cattle saliva, enzymes in feed stuffs and mechanical cleaning. The surface can be protected by a fibreglass or polyethylene insert or by coating the surface with an epoxy resin – best applied when the trough is new.

See *Section 19 - Feeding systems* for further information on the use of coatings to protect the surface of concrete against corrosion and wear.

Trough support structure

Troughs should be enclosed underneath with vertical external sides that extend from the top of the trough to the concrete apron. This provides the trough and piping with some protection from machinery and cattle, and allows cleaning of the apron right up to the trough base.

Fibreglass or polyethylene troughs should be protected by full concrete sides rather than open steel frames.



Rectangular water troughs fit well along fence lines.



Fibreglass insert in a trough (Position D).



Poor design of trough support allows manure to build up, creating odour and encouraging flies to breed.



Unprotected floats can be damaged resulting in an overflowing trough and wet spots within the pens.



Steel cage to protect float



Concrete float cover and a trough cleaning device shaped to exactly fit the trough's internal shape.

Open-framed bases do not fully protect the trough and also allow manure to accumulate under the trough. This enhances fly breeding, promotes odour and makes cleaning more difficult.

Cattle access

Cattle must be prevented from stepping or falling into water troughs by sides extended high enough from the ground and an exclusion bar over the surface of the trough.

Steel or timber frames are constructed over the trough to prevent cattle entry while in-fence troughs can be protected by the fence panels themselves. Fence panels either side of the trough should be reinforced while stand-alone troughs must be protected by a separate structure.

The flow control system and supply and drainage pipework should be protected from damage by cattle and machinery, as when it is located in the void under the trough and contained within an enclosed trough base.

Cattle play with and damage unprotected valves. Besides any costly repairs, the trough will overflow, causing excessive bogging, pen floor damage and odour generation.

Float protection must be sturdy with either an open frame (e.g. weldmesh) or preferably fully enclosed and made from galvanised sheet steel, fibreglass or concrete. Protection covers must be easily removable to allow maintenance access to float valves and gate valves. Float covers reduce available drinking access along the length of the trough.

Aprons

The area surrounding the water trough is a high traffic area. An apron will allow access to the trough under all weather conditions, prevent the ground becoming muddy or holes developing and allow cleaning of manure around the trough.

Concrete aprons should be at least 3 m wide all around the trough. Figures 1 and 2 illustrate typical construction details of a trough located along the pen-dividing fence. A width of 3 m allows full access and supports the full width (2.4 m) of pen-cleaning machinery (e.g. bobcat, loader). Aprons should have thickened edges and reinforcement to support the weight of pen cleaning machinery.

Water troughs need to be level when installed. However as all pens have some slope, there would be 150 mm fall over a 5 m long trough in a 3% pen. Hence, the grade of the apron must vary around the trough. The apron on the upslope side of the trough may be kept level or slope (e.g. 1%) down from the trough.

Figures 1, 2 and 3 illustrate the resulting grades of an apron with a level upslope and located on a pen with a down slope of 3% and cross slope of 0.5%. Figures 5, 6 and 7 illustrate the resulting grades of an apron with a 1% grade way from the trough on the upslope side and located on a pen with a down slope of 3% and cross slope of 0.5%. The greater the pen slope, the greater the difference between the level apron pad and the pen surface. Grading down the apron to tie in with the finished pen surface minimises fill.

During pen construction, the apron is normally cut in to the finished surface (compacted clay or gravel) so that the top of the concrete apron is 30–50mm above the finished surface (Figure 2). This allows for the impermeable manure pen substrate to be 30–50mm in thickness, and therefore level with the finished concrete apron surface. The area cut out between the edge of the apron and finished surface is backfilled with pen surface material.

An alternative is to cast the apron on top of the finished pen surface but this increases the amount of fill required for the pad.

A pad will need to be formed on the finished surface to form a level base for the water trough; this is best built up with crusher dust or similar material and compacted to ensure no settlement.

Figure 3 and Figure 7 show a plan view of the water trough installed on a pen with a slope of 3% and a cross-slope of 0.5%. The grades of the apron will vary along the length of the trough as the apron is graded down to the pen surface, depending on the grade of the apron on the upslope side.

Concrete water trough aprons that are oval in shape reduce ongoing maintenance around water troughs as they eliminate wear points around apron edges, and allow cleaning equipment and machinery to operate around water troughs without catching sharp edges or 'squared' concrete lips. The equipment can operate in a circular motion around the surface of the apron (Figure 4).

Aprons should have a non-slip surface. See *Section 23 – Cattle processing* and *Section 41 – Cattle washing* for information on non-slip concrete surfaces.



Aprons allow cattle to access to the trough under all weather conditions and allow access for cleaning (Position A).

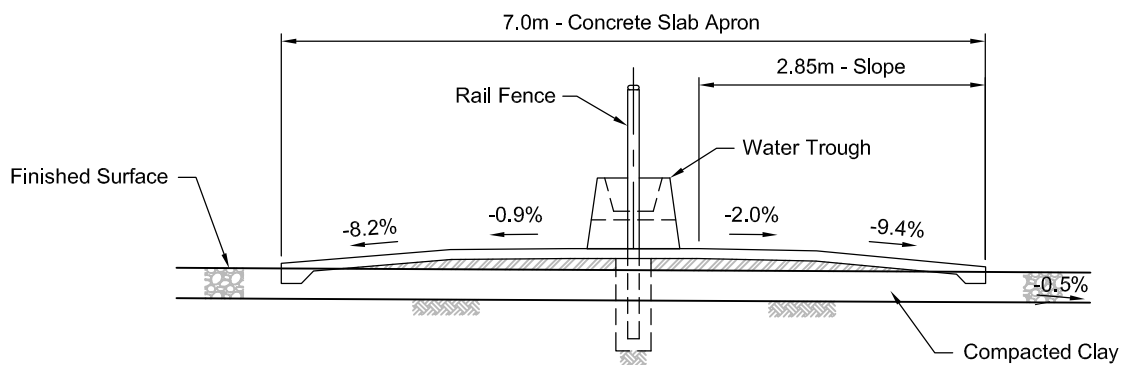

Figure 1. Typical concrete apron cross section details with 0.5% cross slope in pen.

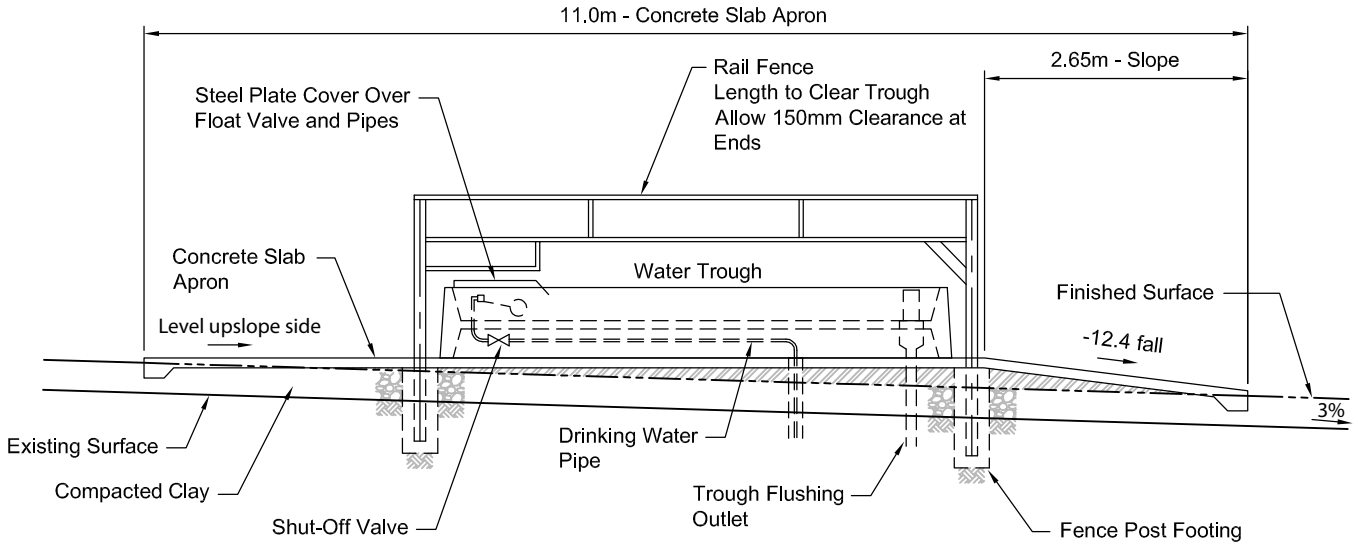
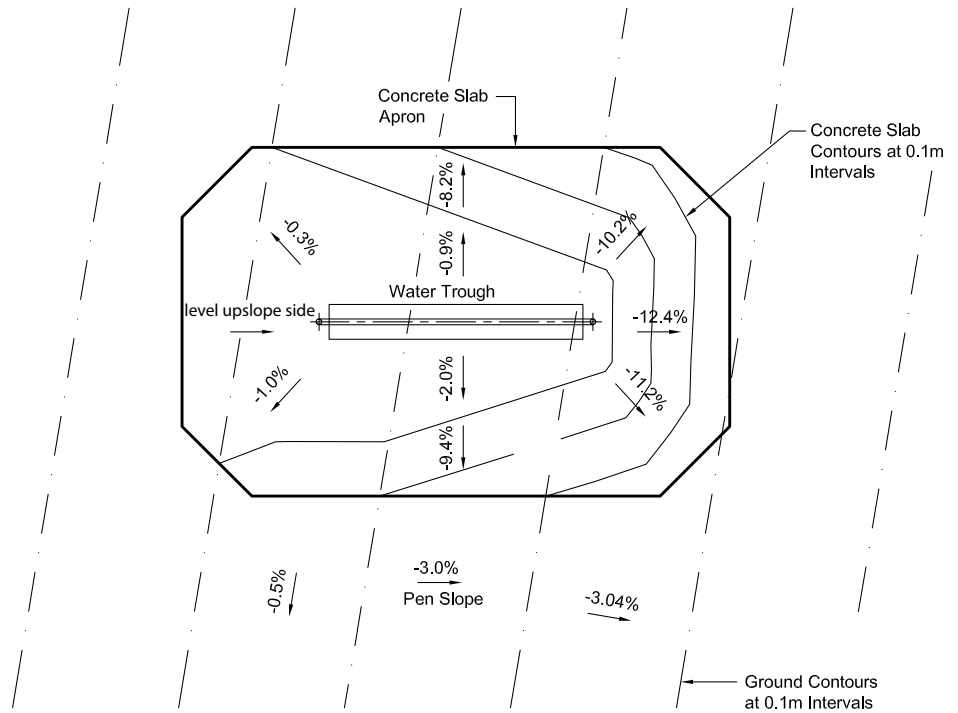
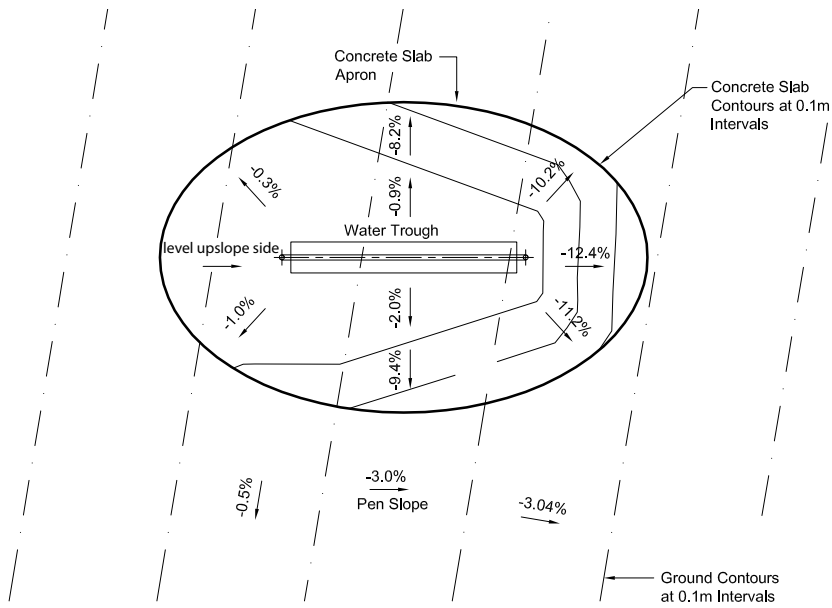

Figure 2. Typical concrete apron long-section details with 3% downslope in pen

Figure 3. Typical concrete apron plan view with level upslope side





Trapeze-shaped water trough centrally placed on an oval-shaped concrete apron.

Figure 4. Typical oval concrete apron plan view with level upslope side

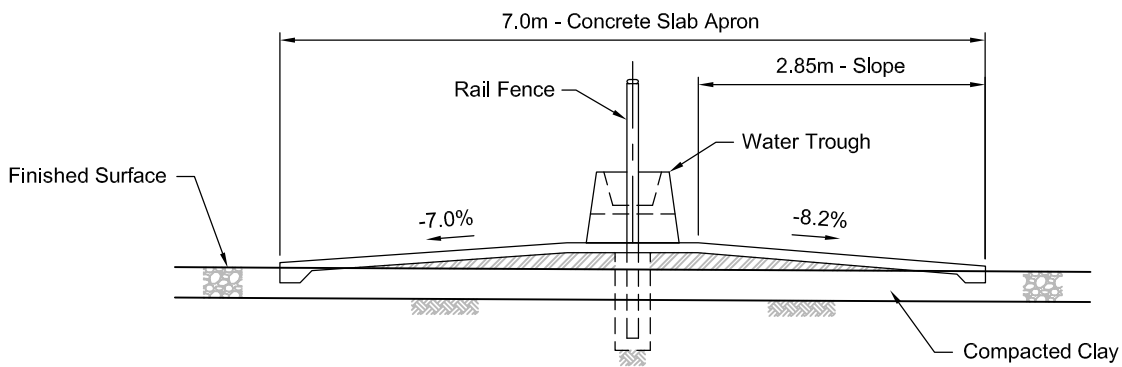

Figure 5. Typical concrete apron cross section details with apron graded down on upslope side

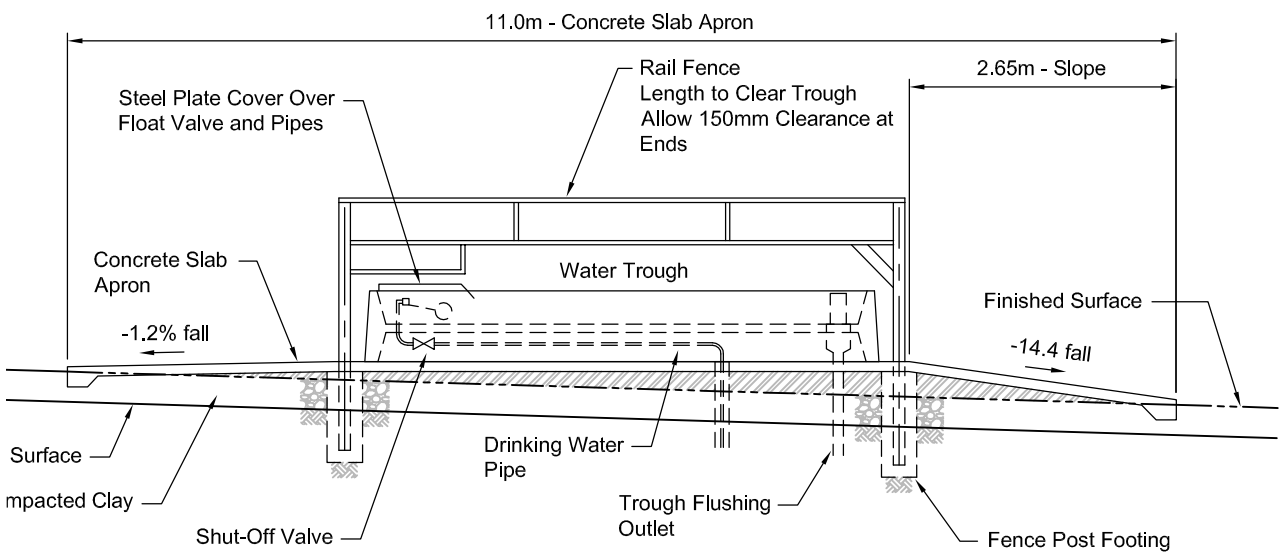

Figure 6. Typical concrete apron long-section details with apron graded down at 1% on upslope side

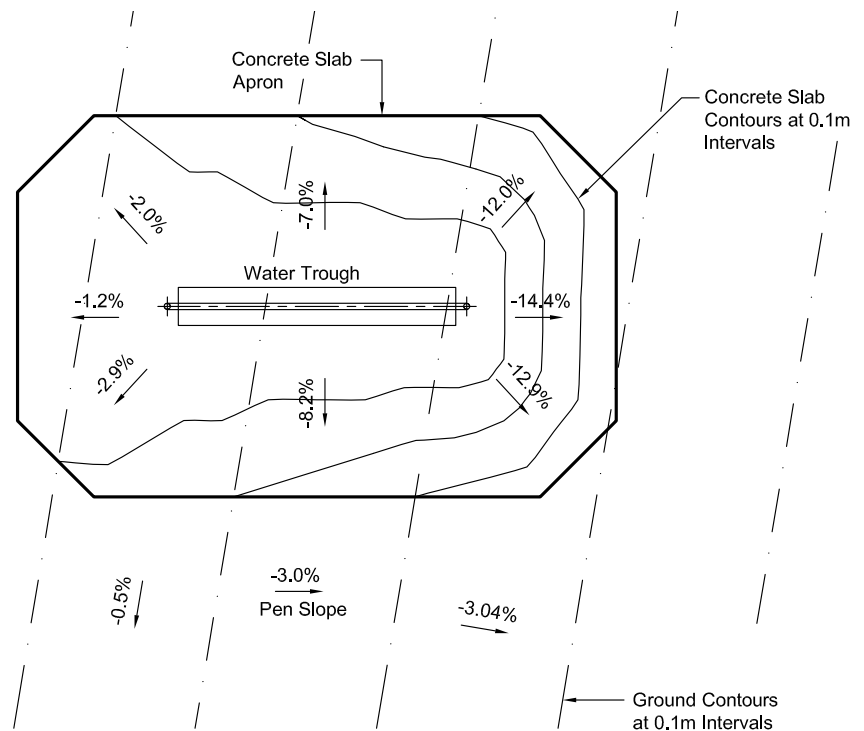

Figure 7. Typical concrete apron plan view with apron graded down at 1% on upslope side



Placing troughs between pens can help secure water supply to cattle. Note good float protection, enclosed sides and an overflow pipe. The trough can be scrubbed with a brush for cleaning.

Flow control

Troughs need some form of water level control to maintain a constant water level and minimise water loss through overflow. Sleeved or seated valves have high flow rates and a wide operating pressure range. For sleeved valves, the water level change activates a ball float to engage a piston, which opens until water level is returned to pre-determined level. For seated valves, the ball float depresses a seal against a seat.

Location in pens

Water troughs can be placed in several locations within a pen. Two locations (A and D in Figure 8) are recommended.

Water troughs (A and B) in the fence line between pens are shared between the two pens. The fence acts as a barrier to cattle entry whereas stand-alone troughs (C and D) must have a separate cattle entry barrier across the surface of the trough. Troughs in fence lines provide backup if one trough is offline due to damage (as long as individual troughs can be isolated).

Troughs in fence lines are claimed to be more readily located by new cattle as they walk the fence line. Two troughs in the fence line distribute cattle so that manure does not build up and traffic is not limited to one area.

Provision of two water troughs per pen ensures that timid cattle have good access to water, although there is a suggestion that there is increased risk of disease transmission if troughs are shared.

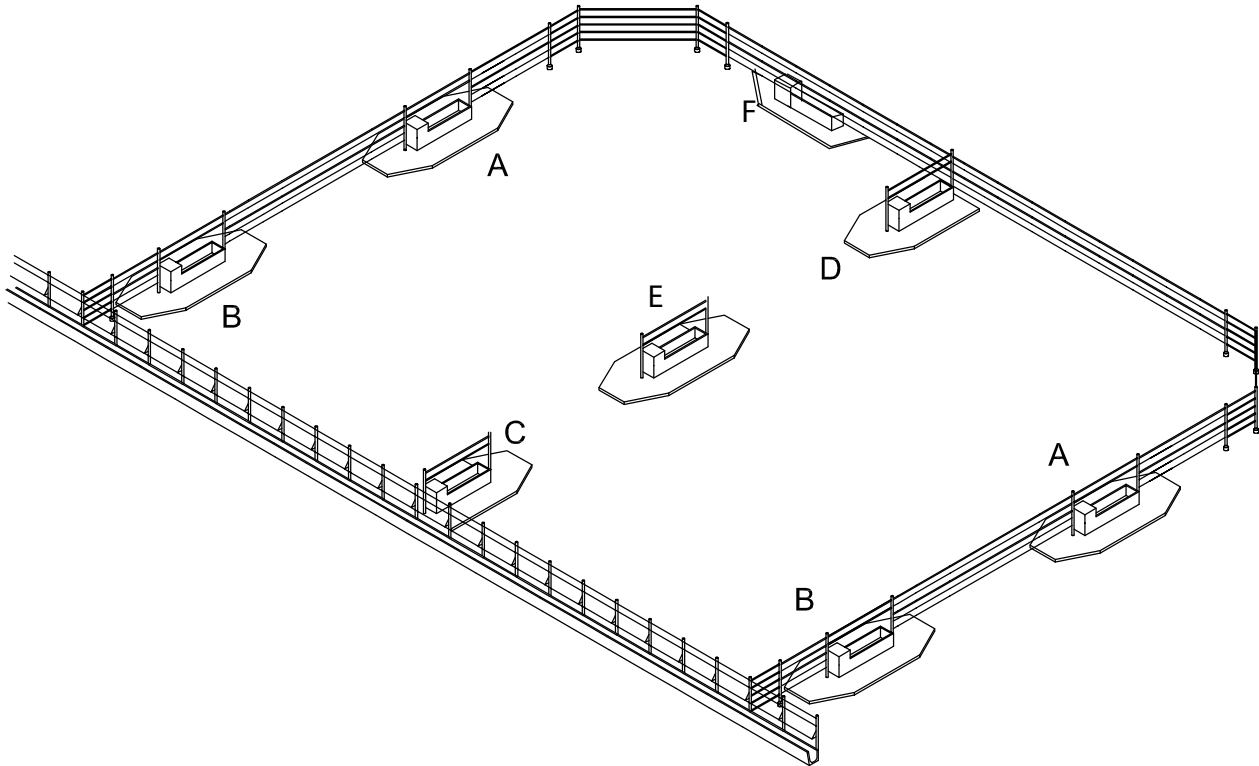

Figure 8. Options for locations of water troughs in pens

As cattle drink soon after feeding, water troughs should not be located relatively close to the feed troughs (B and C). After feeding, cattle hold grain on their muzzles and in their mouth for a time. If the troughs are too close to feed bunks, cattle will transfer more grain across to the water trough, requiring more frequent cleaning. Also water flushed from water troughs in this location during cleaning and the heavy traffic can result in rapid pen floor deterioration and multiple wear points. Troughs in this location will most likely need to be sewered.

If the trough is located on the bottom fence line near the cattle lane/drain (D), overflow, spillage and flushing water during cleaning is conveyed directly out of the pen to the drainage system and wet spots in pens are avoided. New cattle traversing the perimeter of the pen locate the water supply easily. Troughs are also likely to have less feed deposited.

Position E will require a spoon drain or sewerage line to a drainage point in lane or gully. This allows good access for machinery during pen cleaning and will allow cattle to pass easily.

Troughs should never be placed at position F because they prevent drainage from the pen.

If fence line troughs are located close to the cattle lane gates (A), releasing flushing water can cause bogholes in these high traffic areas. While stand-alone troughs located on the bottom fence line flush most conveniently into lanes, they can be difficult to clean around. Water troughs on the fence line near the cattle lane/drain can be easily accessed from the cattle lane.



A water trough placed across the bottom fence will prevent proper pen drainage – a poor design choice.



An overflow stand pipe prevents water from overflowing into the pens if a float valve breaks. The stand pipe is unscrewed for trough draining and cleaning.



Algae and dirty water in troughs can make cattle sick. Troughs must be cleaned regularly.



Leaking water troughs create wet spots in pens and should be fixed as soon as possible. A sewer system would have prevented this problem.

Covering the troughs with some form of shade or placing water troughs under the shaded areas in the pen will reduce the heat loading on the water and the trough. However, the area around the trough will stay wet longer so the concrete aprons may have to be larger. Cattle will tend to congregate under the shade and this may restrict access to the trough.

Position (C) is not recommended as it disrupts pen cleaning and makes it difficult to maintain a uniform, even pen slope.

Drainage of overflow and cleaning water

Water troughs in feedlots need to be cleaned frequently by flushing out the existing water and then adding more during scrubbing.

Each trough must be fitted with a large drainage (flushing) outlet which should be located so that drainage water flows away from the trough, preferably to a drain. A small concrete spoon drain can take water from the drainage point to the pen drain while a sewer system conveying flushing water either directly to the drain, or preferably to the retention pond, is increasingly preferred.

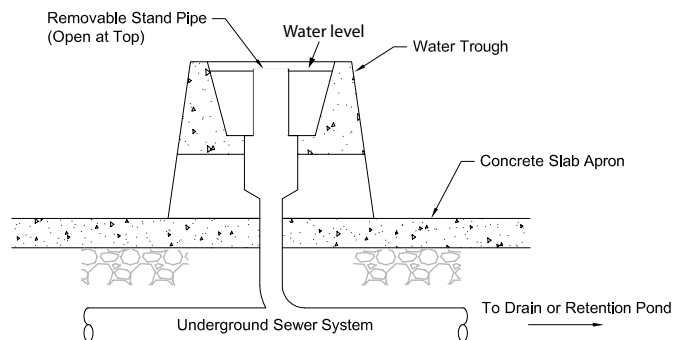

Figure 9. Stand pipe overflow and flushing system

The sewer system will also direct overflow water out of the pen if a float valve is broken or jammed (Figure 9). An alternative to this is to supply a specific overflow structure such as a recessed lip at the lower end of the trough.

Troughs are flushed simply by unscrewing the stand pipe which opens the discharge bung. Dirty water (along with grain and other debris) and flushing water is then conveyed through a network of pipes to the discharge point.

As sewer systems can become clogged by stones, grain and other debris, the underground pipe system needs good slope (>1%) and no sharp bends, while valving can provide a flushing flow. Additional flushing time is recommended to completely remove any sediment.



Trapeze-shaped water trough with galvanised float cover, and hinged neck rail to prevent cattle getting into the water trough. A boot cover on water inlet pipe prevents material from entering PVC delivery pipe. (Position E)

Quick tips

- The water delivery system and water trough capacity must be adequate to meet the daily water requirements and peak demand of the cattle.
- Rectangular troughs fit along fence lines, are easy to clean around with machinery and provide more linear space than an equivalent capacity round trough. Rectangular troughs are more easily cleaned than circular troughs.
- A minimum of 25 mm/head of available linear trough space should be provided during normal conditions
- All troughs should have vertical or near-vertical closed-in sides that extend from the top of the trough to the concrete apron. This prevents manure buildup underneath the trough where it is difficult to remove.
- Troughs should be high enough above ground level that cattle cannot step, fall or be knocked into them.
- Steel or timber frames should be constructed over the trough to prevent cattle entry.
- The flow control system and supply and drainage pipework should be suitably protected from damage by cattle and machinery but easily accessible for maintenance
- A concrete apron at least 3 m around water troughs is essential for this high traffic area and will allow cleaning of manure from around the trough. Aprons should slope a minimum of 2% away from the trough. Aprons should have a rough surface to prevent cattle slipping.
- Surface coatings are best applied to concrete water troughs before they are used.

Further reading

AUS-MEAT, 2014, NFAS Rules & Standards (April 2014), AUS-MEAT Limited, Brisbane, Qld.

Brown, L, 2006, Livestock Water System Design, Livestock Watering Factsheet, Order No. 590.304-1 January 2006, Ministry of Agriculture and Lands, British Columbia.

Blocksome, C.E. and G.M. Powell (eds). 2006. Waterers and watering systems: A handbook for livestock owners and landowners. Kansas State University Agricultural Experiment Station and Cooperative Extension Service, Manhattan, KS.

DAFF, 2013, Australian Animal Standards and Guidelines for Cattle, Department of Agriculture, Forestry and Fisheries, Australian Government, Canberra, ACT.

Kenzie, O and Williamson, K, 2000, Facilities and Environment – Feedlot Water System, Alberta Feedlot Management Guide, Agricultural and Rural Development, Alberta Agriculture.

Landefeld, M and Bettinger, J 2010, Livestock Water Development, Factsheet ANR-12-02, Ohio State University Extension, Ohio State University.

MLA, 2006, Summer feeding of feedlot cattle, Tips and Tools - Heat load in feedlot cattle. ISBN: 1 74036 505 4, Meat & Livestock Australia, North Sydney NSW.

MLA, 2011, A framework for water and energy monitoring and efficiency in feedlots, Factsheet 11: Drinking Water Usage. ISBN: 9781741915969 Meat & Livestock Australia, North Sydney NSW.

MLA, 2011, A framework for water and energy monitoring and efficiency in feedlots, Factsheet 4: Additional water measurement equipment. ISBN: 9781741915969 Meat & Livestock Australia, North Sydney NSW.

MLA, 2012a, National Guidelines for Beef Cattle Feedlots in Australia. Meat & Livestock Australia, Sydney, NSW.

MLA, 2012b National Beef Cattle Feedlot Environmental Code of Practice. Meat & Livestock Australia, Sydney, NSW.

Skinner, B, 2012, An engineer's guide to apron slabs for water points, WEDC, Loughborough University, 2012.

Taylor, K, 2010, Watering Facility Design Criteria for Cattle, Design Technical Note SD2006-1 April 1, 2010, South Dakota Technical Guide.



FEEDLOT DESIGN AND CONSTRUCTION

21. Livestock handling

AUTHORS: Rod Davis and Scott Janke

Introduction

A successful feedlot operation must be able to handle cattle properly to achieve maximum efficiencies, performance and safety while minimising stress on cattle.

Livestock handling facilities should be integrated into the overall feedlot site plan, and must be well designed, easily maintained and kept in good working order.

Livestock handling facilities are necessary for

- receiving and dispatching cattle
- moving cattle for various reasons – drafting, weighing, pen cleaning, pen maintenance
- performing routine health and management procedures
- properly managing and restraining cattle for close observation.

Handling facilities include holding pens, alleys from pens to working areas, forcing pens, races, restraining equipment, drafting pens, electronic recording equipment, catwalks, amenities and loading ramps.

Design objectives

Livestock handling systems should be designed and constructed to ensure that they

- incorporate the principles of cattle behaviour and low stress handling
- facilitate good livestock flow around the feedlot and within individual facilities
- maintain a high level of animal welfare and comfort, thus reducing injuries and stress
- provide a safe and efficient workplace
- can manage biosecurity and emergency animal disease incursions or outbreaks
- allow for any potential expansion.

Mandatory requirements

Compliance with

- Australian Animal Standards and Guidelines for Cattle (DAFF, 2013)
- Australian Animal Welfare Standards and Guidelines for Land Transport of Livestock (Animal Health Australia, 2012)
- National Guidelines for Beef Cattle Feedlots in Australia (MLA, 2012a)
- National Beef Cattle Feedlot Environmental Code of Practice (MLA, 2012b)
- NFAS standards (AUS-MEAT, 2014).

Design choices

Regardless of the size of a feedlot, a number of common functional elements are contained within a livestock handling system. Figure 1 provides a conceptual representation of the relationships and structure between the various elements of a livestock handling system.

Components

Receival and dispatch

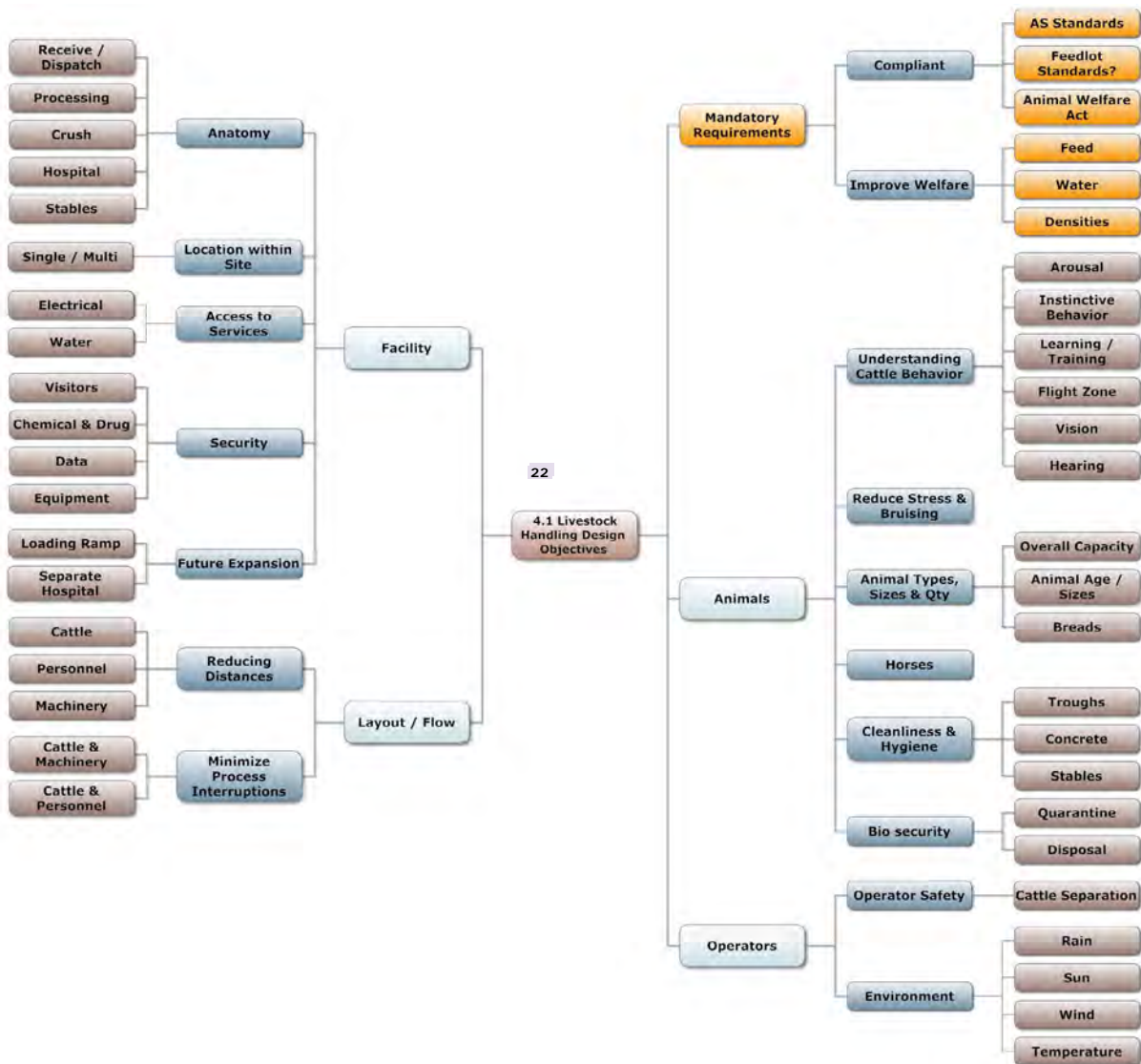

Figure 1. Conceptual representation of livestock handling system design factors

Receival and dispatch facilities allow for the efficient unloading and loading of cattle. They hold cattle on entry after unloading and before processing, or on exit after processing and before loading.

The receival and dispatch facilities may include holding pens, races to loading ramps, loading ramps and catwalks. Larger feedlots may have separate receival and dispatch facilities.

The components of receival and dispatch facilities are outlined in Section 22 – Receival and dispatch facilities.



Receival and dispatch facilities for loading and unloading of cattle.

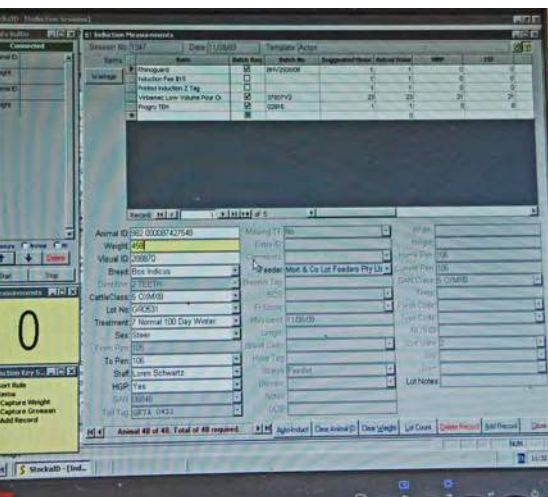

Traceability, health and performance – through information about individual animals recorded on electronic data management systems during processing.



Processing facility at a small feedlot.

Processing facility

The processing facility undertakes activities associated with the induction of cattle into the feedlot, drafting of cattle already in the feedlot, or the exit of finished cattle from the feedlot.

Operations performed within the processing facility can be broadly grouped under traceability, health and welfare and performance.

The components of processing facilities are described in detail in *Section 23*, *Section 24* and *Section 25*.

Hospital facility

Sick or injured animals are removed promptly from production pens and treated, then placed in pens referred to as recovery, sick, treatment, convalescence or salvage pens. Animals are returned to production pens once they recover (or they may exit the feedlot as salvage cattle).

Larger feedlots generally provide an independent hospital facility, but the processing facility may serve this purpose in smaller feedlots.

The number of hospital and associated treatment pens needed depends on the feedlot size, layout, risk profile and preferred method for managing sick animals. The components of hospital facilities are described in *Section 36*.

Stables

Horses are used in most feedlots for pen riding (daily cattle observations) and for moving cattle around. Facilities for stabling and paddocking these horses should ensure their health and welfare.

The components of stable facilities are described in *Section 37*.

Location within site

The location of the livestock handling facilities within the overall feedlot site layout should allow for

- access for livestock transport vehicles (see *Section 13*)
- access to services (see *Section 3* and *Section 8*)
- good drainage (see *Section 10*)
- access for machinery for cleaning or emergencies (see *Sections 9* and *13*)
- security and biosecurity (see *Section 26*)
- proximity to production pens (see *Section 2*)
- traffic flow patterns (see *Section 2*)
- operational integration (see *Section 2*)
- future expansion (see *Section 1*).

Sometimes more than one set of livestock handling facilities may be needed.

A process flow diagram of livestock handling at a feedlot is shown in *Figure 2*.

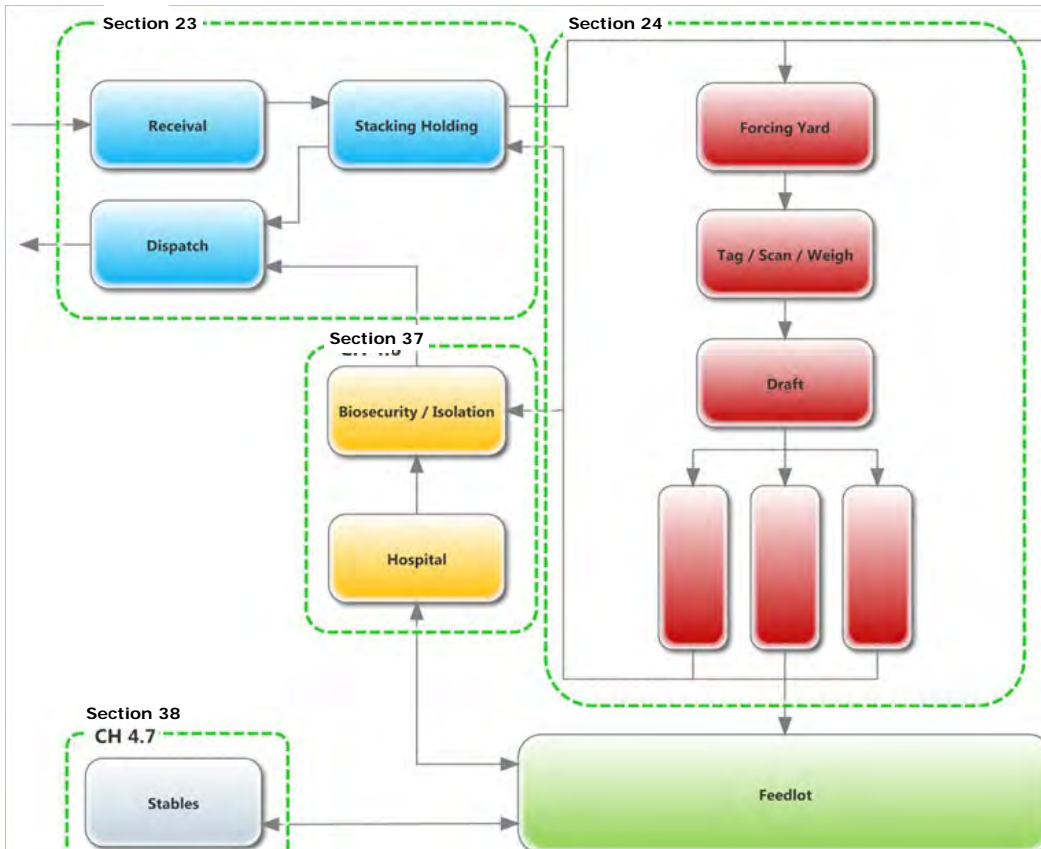

Figure 2. Livestock handling process flow diagram

Access to services

Services needed in the livestock handling facilities include electricity, water, data connections to office/internet, mobile phone coverage, drainage and product storage.

Security

Security needs to be considered for cattle, visitors (See *Section 26*), veterinary chemicals (See *Section 39*), data, equipment and against theft.

Good lighting is needed for unloading and loading livestock during the night, as is security lighting and lockable gates in the livestock handling area. However, lighting should not throw sharp contrast between light and shadow.

Restricted areas should be distinctly signed and visitors should be given workplace health and safety (WH&S) instructions before entering livestock handling facilities and supplied with relevant safety equipment.

Computers for access to feedlot data should be password protected and placed in a lockable cabinet to prevent tampering or theft. Locks for all powered equipment will prevent unauthorised use.

Cattle theft should be discouraged at every opportunity by installing lockable access gates and roadways.



Processing facilities should be designed to minimise stress for cattle and handlers.



Protection from the sun and weather reduces stress on workers and improves their cattle handling performance.

Future expansion

Potential future expansion is easier to include in the initial planning stage of a new feedlot than after construction has started or is completed. Expansion may include new handling and processing facilities.

The following upgrades may need to be considered sometime in the future

- separating the hospital treatment area from the induction area
- increasing the number of loading or unloading ramps
- separate loading and unloading areas
- addition of pens sized to hold one transport load of dispatch cattle – for double deck, B-double or road train
- addition of a cattle wash facility.

Reducing distances

An important element to any feedlot layout design is the distance travelled by animals, people, plant and machinery to each process. Some of these may be more critical in terms of safety and efficiency, for example, injured or sick cattle are not able to travel as far or fast as a feed delivery vehicle. Similarly, heavy finished cattle should walk only short distances and preferably downhill when being marshalled for load out.

Minimising process interruptions

Layouts also need to consider animal, people and machinery process paths and operation times; for example, a feed road should not cross the main cattle lane into a processing facility (see *Section 2 – Site layout*).

Understanding cattle behaviour

Professional handling of livestock in a feedlot requires knowledge of cattle behaviour and access to good facilities. Some aspects of cattle behaviour directly affect how cattle handling facilities should be designed.

Facility designers and cattle handlers should understand the principles of cattle behaviour; this will help to reduce stress to the cattle and handlers, optimise the flow of the cattle and operational efficiency while lowering the risk of injury.

Stress

Stress reduces the ability of the animal to fight disease, limits weight gain, affects carcase value and ultimately meat eating quality.

The degree of stress is determined by three major factors – amount of contact with people, quality of handling and genetics of the cattle. Frequent, gentle handling will reduce stress. *Bos indicus* and *Bos indicus*-cross animals are more sensitive (temperamental) than British or European breeds.

Cattle, because of their size, strength, speed and potential for aggression, need to be handled thoughtfully and with confidence. The most important aspect of handling any animal is to be able to recognise and interpret its reactions. The animal’s ‘body language’ will indicate its probable actions.



Stress-free cattle will keep eating and gaining weight.

Cattle have good memories and an animal's previous experiences will affect its reaction to handling. Animals that have been handled roughly will be more stressed and difficult to handle in the future; those that are handled gently and have become accustomed to handling procedures will exhibit little stress when handled.

Principles of handling

A number of basic behavioural principles of cattle handling are based on how cattle perceive their world. The following is a list of handling principles that can improve the ease of handling cattle.

Arousal

The basic principle is to avoid getting the animal excited. Highly agitated animals are more likely to make sudden violent movements and behave in a self-protective way either by running away (flight) or fighting back (fight). Cattle can become excited in just a few seconds, but it can take 20 to 30 minutes for the heart rate of severely agitated cattle to return to normal.

Normally it is desirable to keep cattle as calm as possible, but sometimes they may need to be temporarily excited for particular purposes, such as forcing lead animals through a gateway.

Dogs and electric prodders arouse animals and should never be used in the handling facilities.

Instinctive behaviour

The animal's natural instinct to escape can be used when handling cattle that have had little contact with people.

Flighty cattle may not understand the flow system of a new handling facility, but their instinctive behaviour for flight can be used so that they 'escape' to where the handler wants them to go.

Animals' instinctive behaviour must be considered when designing handling facilities.

Learning/training

Cattle have good memories so their handling experiences should also be made as pleasant as possible. *Bos indicus* cattle, in particular, soon become accustomed to the way in which they are worked through handling facilities. The best procedures for working stock in handling facilities should be developed and adhered to, and be part of an overall employee training plan.

Flight zone

The flight zone can be described as the animal's personal space, and understanding this is the key to easy and quiet handling. The size of an animal's flight zone is determined by factors such as its wildness and arousal, and the angle of the handler's approach.

Cattle can be moved easily by working on the edge of the flight zone (Figure 3). When a handler penetrates the flight zone, the animal moves away; when the handler retreats from the flight zone, the animal will stop moving. The handler needs to know when and where to penetrate this zone, and when and where to retreat so that the animal moves quietly in the desired direction.



The animal on the left is staring and becoming agitated. Avoid exciting cattle during handling.



Regular steady handling by pen riders results in quiet animals that continue feeding.



Its fast movement suggests that this animal is becoming stressed by the handler's close presence.

The handler must be close enough to the animal to make it move, but not so close as to cause it to panic and flee. If the cattle start moving too fast, the handler must retreat.

Cattle look in the direction they are about to go and the position of an animal's head will determine the way it will turn. Cattle move most effectively if they can see the handler at all times. Experienced handlers use the point of balance of an animal to move it. Looking from a side view, this means behind the shoulder; from in front, it is from the centre of the head as shown in Figure 3. An animal is best driven when the handler is situated at a 45–60° angle from a line perpendicular to an animal's shoulder.

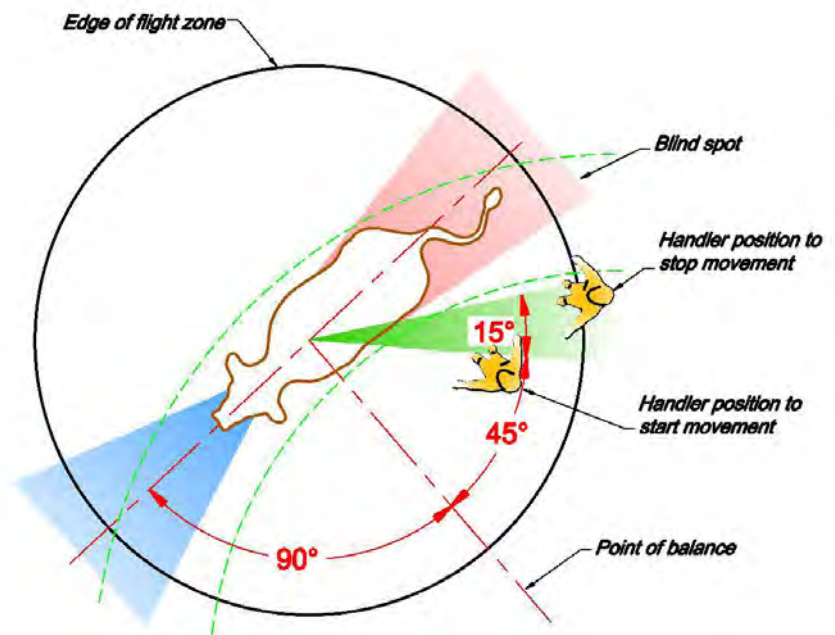

Figure 3. Flight zone of cattle



Curved races encourage steady movement of cattle. Operator safety is promoted by external walkways that separate cattle and handlers.

This same principle applies to driving mobs of cattle. A mob of cattle has a collective flight zone around the group. When the handler penetrates the zone, the mob will move.

When a mob is progressing in the right direction, the handler works on the edge of the flight zone. By alternately entering and retreating from the flight zone at the optimum position of 45–60°, the handler keeps the mob moving at the desired pace.

Any change in direction of the mob, or breakouts, can be anticipated by noting the head movement of the cattle at the lead and edges of the mob.

When cattle are in an enclosed space such as a gateway, alley or forcing pen, penetrating deeply into the flight zone can result in animals panicking, jumping rails or turning back on the handler.

Cattle will normally run to a point of escape (often an entrance gate). their natural movement is in a curved direction to where they came from, thus they often tend to circle the handler in a yard. This is the principle used in curved races. The curved race encourages steady movement of cattle around the race, whereas in a straight race, cattle will often move quickly forward, baulk and then move backwards.

A curved race has a natural anti-backing effect and tends to be self-feeding. Curved races are usually used as a lead-up to crushes and/or loading ramps.

Vision

Cattle do not see the world as clearly and sharply focused as humans do, and they take more time to process what they have seen. Cattle have panoramic vision in excess of 300 degrees with a blind spot only directly behind their body (Figure 4).

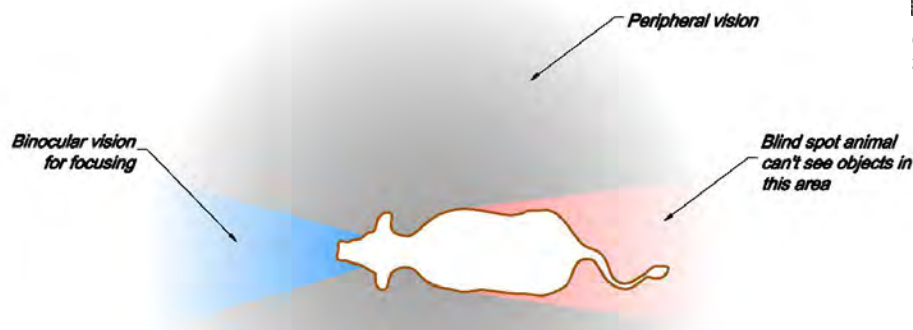

Figure 4. Cattle vision

Hence, cattle can see all around themselves without turning their heads and are often distracted by motion off to the side.

Sheeting on the sides of races, yards and the loading ramp is used to make animals focus on the exit; it eliminates baulking from visual distractions, and thus improves flow.

Cattle have poor depth perception of nearby objects and also limited vertical vision, in particular when they are moving with their heads up. Because they have only about 60 degrees of vertical vision, cattle have to stop and put their heads down to focus on something on the ground.

Because of this limited vertical vision and inability to focus quickly, cattle baulk at shadows or any strong contrast in light, and at strange objects on the ground. A dark shadow on the ground may appear to cattle as a deep crevasse.

Lighting at receipt or processing facilities should not throw strong shadows or be directed straight at the advancing cattle. Cattle depend heavily on their vision and are easily motivated by fear.

Hearing

Cattle can hear both lower volume and higher frequency sounds better than people. They are more sensitive to loud, high pitched noises, which induce fear. Gates in races should be designed (and lubricated) to reduce harsh metallic noise such as clanging or squeaking. Although cattle hear extremely well, they are less able to locate the source of a sound and again may take fright.



Cattle have a blind spot directly behind their body.



Sheeting on the sides of a race eliminates baulking from visual distractions.

Reducing stress and bruising

An understanding of cattle behaviour combined with well designed facilities will reduce stress on both handlers and cattle. Minimising stress on cattle encourages good immune responses to infection, and acclimation to the feedlot while minimising injury and bruising.

Biosecurity

Feedlot cattle sourced from diverse livestock markets or grazing properties may introduce a risk of infection and disease. The livestock handling system must ensure that any disease or problem is detected early and dealt with promptly and in isolation.

Operator safety

The best way to improving operator safety is to separate operators from the animals where possible. This can be achieved by using horses in the pens, having external walkways in the processing and crowded handling facilities, and using crushes for treatment of individual animals.

Handlers in pens should be provided with a means of rapid exit, such as man gates. Using one-direction gates, gates that can be operated from outside the animal area, or gates with appropriate safety catch mechanisms can reduce the chance of livestock forcing gates back onto handlers.

Environment

Environmental conditions such as temperature, rain, dust and wind need to be considered in the design of livestock handling facilities. See *Section 24* on buildings and structures.

Ambient temperature can affect the efficiency of handling operations. Whether it is hot, cold, raining or windy, a covered processing facility helps improve operator efficiency and animal comfort. Sprinklers may need to be placed strategically to dampen down dusty facilities.



Man gates allow handlers to exit pens rapidly and safely.



A covered processing facility improves operator efficiency and animal comfort.

Quick tips

- Livestock handling facilities must be integrated into the overall feedlot layout.
- Good handling techniques for livestock require a knowledge of cattle behaviour and access to well designed facilities.
- Well designed handling facilities will lessen stress on cattle and operators.
- Minimise the distance travelled by animals, handlers and machinery for each process in the livestock handling system.
- Cattle have panoramic vision in excess of 300 degrees but have a blind spot directly behind the back of their head and body.
- Cattle have poor depth perception but can hear a wide range of sound frequencies, particularly high frequency sounds
- Cattle depend heavily on their vision and quick movement may motivate ‘flight or fight’
- Environmental conditions affect the efficiency of handling operations.

Further reading

Blackshaw, J. (1986), Notes on some topics in applied animal behaviour, University of Queensland, St. Lucia. (www.animalbehaviour.net)

Herve, J. Szentleki, A. and Tozser, J. (2007), Cattle behaviour – Perceptions, relationships, studies and measurements of temperament, *Animal Welfare Ethology and Housing Systems*, Volume 3, Issue 1, Godollo.

Smith, B. (1998), *Moving ‘em: A guide to low stress animal handling*, Graziers Hui, Hawaii.

Dr Temple Grandin’s website: *Livestock Behaviour, Design of Facilities and Humane Slaughter* (www.grandin.com)

Bud Williams Stockmanship School (www.stockmanship.com)

Animal Health Australia (AHA) (2012). *Australian Animal Welfare Standards and Guidelines - Land Transport of Livestock*. AHA, Canberra.

AUS-MEAT, 2014, *NFAS Rules & Standards* (April 2014), AUS-MEAT Limited, Brisbane, Qld.

DAFF, 2013, *Australian Animal Standards and Guidelines for Cattle*, Department of Agriculture, Forestry and Fisheries, Australian Government, Canberra, ACT.

National Guidelines for Beef Cattle Feedlots in Australia, Meat & Livestock Australia, 2012a Sydney, NSW.

MLA, *National Beef Cattle Feedlot Environmental Code of Practice*. Meat & Livestock Australia, 2012b Sydney, NSW.



FEEDLOT DESIGN AND CONSTRUCTION

22. Receiving and dispatch facilities

AUTHORS: Rod Davis and Scott Janke

Introduction

Feedlots can receive cattle from various sources and from across a wide geographical area. When cattle have reached their marketable weight or specification, they need to be transported from the feedlot to an abattoir. The process of receiving and dispatching cattle from the feedlot requires well designed cattle handling facilities.

Feedlots may have one facility which handles both the arrival and dispatch of cattle or a separate facility for each process. The decision usually depends on the size of the feedlot and the volume of cattle handled on a regular basis.

Receival and dispatch facilities are high-traffic areas for cattle, personnel and livestock transport trucks. These facilities should allow for safe, low stress ingress and egress of cattle to and from the feedlot complex while maximising worker safety. Loading and unloading cattle are some of the more stressful events of the cattle handling process, and the quality of the facilities can have a big influence on stress levels and productivity outcomes.

Requirements for any receival and dispatch facility must take into account the numbers and type of animals that are predicted to be handled, while also being flexible enough to accommodate the wide range of vehicles found in the livestock transport industry.

A receival and dispatch facility typically includes holding pens, forcing pens, races and loading ramps.

Design objectives

The receival and dispatch facilities should be designed, constructed and maintained to ensure

- a natural flow of cattle from the holding pens to the transport vehicle or vice versa
- adequate space to allow livestock trucks to comfortably manoeuvre into position for side and rear loading and unloading
- even, well-drained approaches to the load/unload ramp
- stable unloading and loading equipment
- minimised stress and bruising on cattle
- maximised cattle welfare and worker safety

Mandatory requirements

Compliance with

- Australian Animal Standards and Guidelines for Cattle (DAFF, 2013)
- Australian Animal Welfare Standards and Guidelines for Land Transport of Livestock (Animal Health Australia, 2012)
- National Guidelines for Beef Cattle Feedlots in Australia (MLA, 2012a)
- National Beef Cattle Feedlot Environmental Code of Practice (MLA, 2012b)
- NFAS standards (AUS-MEAT, 2014)

Design choices

While all receive and dispatch facility layouts are unique, the functional elements contained within each are similar and largely independent of feedlot size.

Figure 1 provides a conceptual representation of the relationships and structure between the various elements of cattle receive and dispatch facilities.

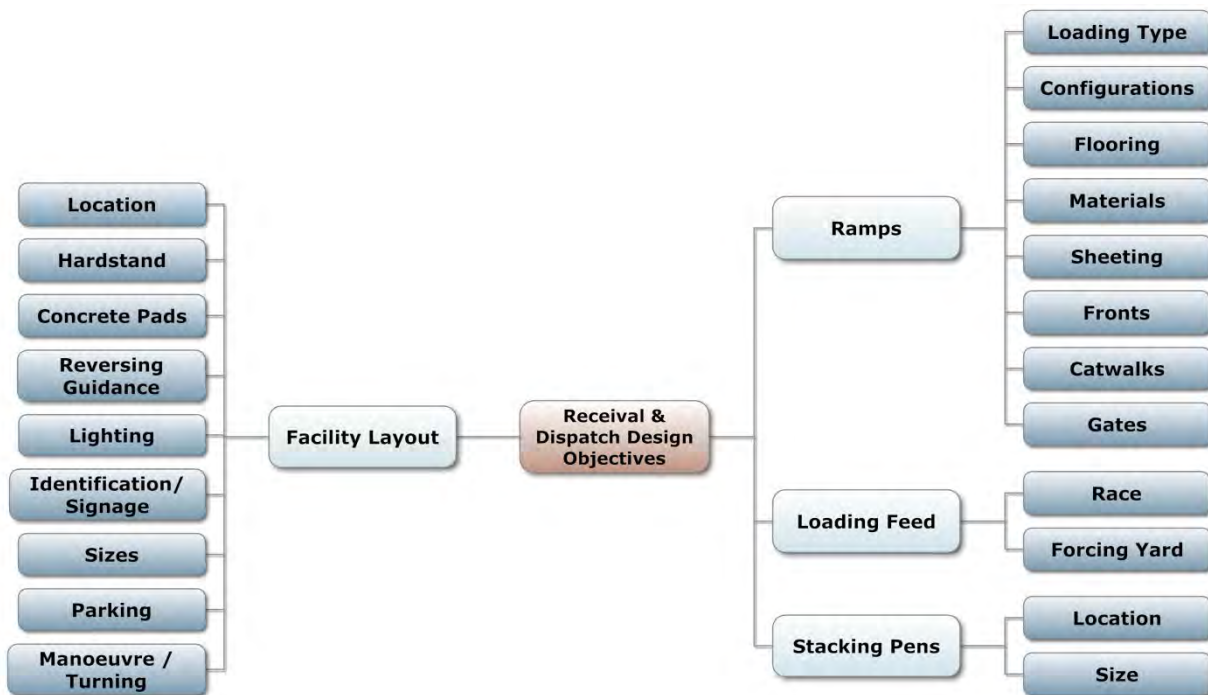

Figure 1. Conceptual representation of cattle receive and dispatch design factors

The facility layout will vary with the type of cattle (e.g. Brahman versus European, large versus small body size), number of animals to be handled, vehicle loading methods, space restrictions and personal preferences for facility layout.

The design should accommodate all the operations to be performed as efficiently and economically as possible to minimise stress on animals and operators.

Receive and dispatch facilities will include various associated components including holding pens, forcing pens, races, catwalks and loading ramps and vehicle manoeuvring areas. Some of these elements serve multiple purposes within a receive and dispatch facility and the associated processing facility.

Receive and dispatch facilities must

- be able to accommodate varying types and configurations of livestock transport vehicles expected
- be able to accommodate the type and number of cattle to be handled
- provide access to holding pens and processing facilities
- prevent injuries to and minimise stress on cattle
- prevent injuries to operators



Loading and unloading ramps

- consider the environmental conditions – rainfall, wind direction, daily temperature, shade, dust and noise
- use fence sheeting to prevent cattle baulking
- provide feed and water for unloaded cattle
- provide water for cattle to be loaded
- have lockable slide gates to prevent accidental escapes, illegal/unauthorised cattle delivery or removal, provide quarantine measures
- consider size and shape of the components
- consider vehicle traffic and cattle flow
- provide drainage
- provide non-slip surfaces
- consider access for truck drivers
- consider type of construction materials (wood, steel, concrete) against corrosion or rot
- position ramp so that the truck driver may back in with a good view from the driver's side of the vehicle. (It is almost impossible for a semi-trailer to be backed accurately to a ramp on left hand lock)
- consider the direction of sun in morning and evening; avoid walking cattle directly towards bright light (artificial or sun)
- consider lighting to avoid strong contrast between bright light and shadows
- consider cleaning – pressurised water, skid steer access
- vehicle access to deal with downer cattle.



Concrete hardstand in front of loading ramp

Location

The location of the receival and dispatch facilities within the overall site layout must provide good access for trucks and trailers and appropriate traffic flow of livestock transport vehicles. The movement of livestock vehicles must not interfere with the movement of normal feedlot vehicles.

Section 2 outlines design choices for the location of receival and dispatch facilities within the overall feedlot layout, while various factors that will influence the location are outlined in *Section 21 - Livestock handling*.

Hardstand

The hardstand is the area around the loading ramp that is used by the trucks. When rear loading is used, the area directly in front of the loading ramp should be relatively flat and well drained. A good solid hardstand will reduce future maintenance. *Sections 13 - Access and internal roads* and *17 - Pen and road surfaces* outline design choices for livestock vehicle turning areas.

Concrete pads

Concrete pads in front of the loading ramps are used for larger operations where frequent use and rain can cause ruts and erosion. These pads also help maintain the unloading height and levelness of the trailer.

The concrete pad should have a minimum area of 3.5 m in width and 5.25 m in length to accommodate the rear axle group of the trailer. The concrete pad should be 175–200 mm thick and reinforced with a mixture strength of between 25 MPa and 32 MPa to support the trailer loadings and provide durability.

Reversing guidance

Guides can aid trucks reversing. These may include painted straight lines or a row of cones on sealed roads; a concrete strip for unsealed gravel roads; timber rails or steel balustrades at ground level. Solar indicator lights can be fitted to assist at night.

Lighting

If night time loading or unloading is likely, the area should have appropriate lighting. Lighting should cover all areas including the stacking/holding pens and personnel access areas, with a number of lights to prevent shadows that can cause cattle to baulk. Lighting should not affect the truck driver's line of sight or be reflected in the reversing mirrors.

Halogen lighting with a diverse lighting pattern provides soft yet adequate light; it also minimises contrast between shadow and bright light.

Identification

If there are multiple ramps in the facility, identifying each one will help communicate the correct ramp to the truck driver. Identification commonly uses a single letter or number, but needs to be large enough to be visible from at least 100 m away.

Parking

If receiving or dispatching a large number of animals requires a number of trucks, a suitable stationing or parking area may be needed for the waiting trucks. Inadequate road space leads to congestion, trucks travelling unnecessary distances from poorly located parking areas and road safety concerns with internal feedlot traffic.

Manoeuvre/turning

Adequate room is required for turning and reversing, with the area depending on the size of the trucks and the number of trailers.

Fully-loaded livestock transport vehicles require a significant turning area to prevent road damage and cattle instability.

Floats

Horse trucks will require a loading/unloading area that has good lighting and adequate space on the ramp. Support bars and braces must be removed or be removable to prevent injury to horses during loading and unloading.

Horse floats rarely require a ramp for loading or unloading as they are low to the ground and generally have their own drop-down ramp attached. However, a tie-up area near the horse loading area is recommended.



Markers embedded into paving as a guide for reversing vehicles



Identification number on a loading ramp



Fluorescent strip lights installed over loading ramp for night loading

Loading and unloading ramps

Well designed and constructed loading facilities result in quicker, safer loading with less stress on livestock carriers, stock and owners.

Cattle need a loading dock or loading ramp between the holding pens and the livestock transport vehicle.

Docks

A loading dock has the appropriate step in ground level so that the level of the receival/dispatch pens are the same height as the floor of the livestock transport vehicle or trailer.

Loading docks are used if the topography of the site has a natural slope or easily engineered step or when the cattle yards are at the same height as the trailer deck.

In this case, the truck hardstand is usually about 1.2 m lower than the yards and a concrete retaining wall is used at the edge of the yards to provide a place for the truck to back up to. For a single deck loading, a ramp is not required and for double deck loading, only the upper deck requires a ramp. A dock reduces the need for catwalks when loading only single decks.

Ramps

A loading ramp is used to elevate cattle to the standard height of the livestock transport vehicle trailer and is the most commonly used system for loading and unloading of cattle.

Loading height will vary slightly with the type of livestock transport vehicle to be used, but is generally 1.1–1.2 metres for most body trucks and semi-trailers.

Livestock transport vehicle trailers can be loaded through the back (end load) or through the side (side load). All trailers are equipped with rear loading and those having both rear and side are becoming more common.

For rear loading, the livestock transport vehicle needs adequate distance in front of the ramp (or dock) to turn, straighten and reverse. For side loading, the livestock transport vehicle path must clear any fences, be straight when it reaches the ramp (or dock) and without a sharp turning radius. See *Section 2.4 Access and internal roads* for further information on livestock vehicle turning areas.

Baulk gates or ramp flaps should not protrude from the front of the loading/unloading ramp as they can be damaged during vehicle alignment for side loading.

Ramps are permanently located; the handling facility layout starts from the position of the loading ramp that is needed for truck access and for the type of trucks intended to be used.

As loading ramps are the most common loading system in Australian feedlots, further discussion on these follows.

Ramp configurations

Styles of ramp design include single deck, double deck and an unloading dump (fast unload).



A single deck loading dock



Single deck steel loading ramp

Single deck

The single deck ramp is the most common. Double deck trailers can still be loaded and unloaded from these using the internal ramp of the double deck trailer. However, as the internal ramp of a double deck trailer is steep, double deck ramps are recommended for larger finished animals.

A loading ramp should have a non-slip surface and be narrow, as in a race, with an minimum internal width of 710 mm so that cattle will load in single file and cannot turn back.

At the top of the ramp, a level platform about 2–3 m long will allow cattle to balance and gain more confidence to move onto the different flooring material of the trailer.

A slight curve or deviation in ramp direction will utilise natural stock movement principles and improve the animals' willingness to move up and down the ramp.

Loading is easiest with a slope of about 20 degrees; this is derived from the best length of an animal's stride being 450 mm with a rise of no more than 100 mm. Ramps steeper than 20 degrees will generally inhibit stock flow.

Stock will generally flow well with a gentle stepped ramp of around six metres in length to reach the standard 1.2 metre loading height.

Adjustable ramps

Adjustable ramps allow their height to match that of the trailer as trailer suspension and body type can vary. A small step between trailer and ramp is acceptable as the ramps themselves can be stepped types, but there should not be a gap between trailer and ramp where an animal can get a leg caught. Some single adjustable ramps can be raised or lowered between upper and lower decks; these act like the trailer's internal ramp but provide a lower degree of slope, better footing and a less stressful approach into the stock crate. Alternatively, a hinged drop-down plate can be used to span between the ramp and the truck.

Double deck

For larger operations with more or larger cattle, a double deck ramp can reduce loading and unloading time by not having to use the internal ramp of a double deck trailer. The top and bottom decks can be loaded simultaneously by alternating groups of cattle from the dispatch pens.

Unloading dumps

For unloading only, a truck-width ramp like that used for unloading machinery can be used. These ramps are often termed unloading dumps, dump ramps or wide unloading ramps. The unloading dump helps reduce unloading time and is normally constructed alongside a narrower loading ramp sharing a common fence.

The unloading dump improves animal welfare with less stress on cattle and truck driver due to the ease and speed of unloading.



Adjustable steel ramp for access to double deck livestock vehicles. Note the adjustable batwing gates on the top deck platform.



Double deck steel ramp for loading livestock transport vehicle. The front of the ramp has batwing gates and a short platform.



Double deck ramp – side loading of livestock transport vehicle



Unloading dump



Concrete ramp with steps with pattern stamped into concrete to provide a non-slip surface.



Spring-loaded front with D-mould rubber for cushioning impact.

Flooring

The loading ramp should have a slope of no more than 20 degrees with a floor of concrete, steel or timber; timber or steel floors are more susceptible to rot or corrosion.

Ramp floors should give good grip, be easy to walk on, not flexible and bouncy, and should not resonate or create undue noise. Anti-slipping techniques may include cleats on wooden, steel or flat concrete floors or grooved concrete. See *Section 24 – Buildings over processing facilities* for more information on grooves in concrete flooring.

Concrete floors may be suspended and poured on site with steps/grooves pressed in when pouring. Concrete provides a strong stable footing with no noise. Steel floors should not move or buckle under weight and animals should not be able to see through ramp floors.

If cleats are used, they should be 300 mm apart and protrude at least 40 mm for a ramp slope of 1 in 5, or higher for steeper slopes. Where side sheeting is not used or does not extend to the floor, the cleats should extend beyond the width of the ramp by about 100 mm on both sides.

Sheeted flooring should have drainage to minimise the build up of manure, dirt and moisture.

Soft flooring such as rubber matting may be used. See *Section 24 – Buildings over processing facilities* for more information on soft flooring.

The best floor for the wider dump ramp is a non-slip grooved concrete base poured on site before the rest of the ramp is constructed. This would include associated infrastructure such as personnel access paths on the outside.

Materials

Any combination of materials can be used in the construction of the facility, the choice depending on local availability of materials and budget constraints. The key design criteria will be to balance strength, durability and cost.

The main material used for panels in yards is steel. Steel products are available in various profiles e.g. round pipe, oval pipe, square section (RHS), rope, cable and sheeting, and various surface finishes (e.g. painted steel, galvanised, stainless).

There should be no protrusions or sharp edges in materials and finishes.

Timber and concrete are less frequently used now. Good quality timber is becoming expensive and can still suffer from rot and splintering. Concrete rails will not rust or rot but they are susceptible to breakage from impact either from cattle or cleaning machinery, and cannot be repaired.

Sheeting

Sheeting the sides of the forcing pen, lead-up race and the loading ramp makes animals focus on the exit, eliminates baulking from visual distractions and thus improves flow. Cattle are generally calmer and easier to manage up the loading ramp. Some ramps incorporate a mid-slot in the sheeting, which may be only at the

flat sections of the ramp to allow handlers on the ground to see the movement of cattle in the ramp. Sheeted ramp sides prevent cattle getting legs caught.

Sheeting materials include sheet metal, rubber belting or form ply. Sheeting is typically 1200 mm in height.

Fronts and buffers

Fronts may be fixed, pivoting or spring-loaded. Fixed fronts commonly use timber or D-mould rubber buffers against which the truck backs. A horizontally-pivoting front allows minor out-of-alignment of the trailer to the ramp, preventing a gap. The spring-loaded front also accounts for minor out-of-alignment as well as small variations in distance from the ramp; this is useful in double loading ramps where the hardstand in front of the ramp is not exactly level. A spring-loaded front helps take up any gap at either the upper deck and ramp or lower deck and ramp.

Fronts can also have a short hinged platform mounted to the loading ramp; this platform drops down to cover the gap between the truck and ramp. Short panels (called batwings) are fitted to block off the gaps at the two sides between the truck and the ramp. Batwings can be as a fixed panel or a swinging gate; they are also used when side loading and the trailers side loading gates can be chained open to them.

A flexible buffer on the front of any ramp will protect both the ramp and the livestock transport vehicle trailer from damage. The buffer should also adjust to the angle of the livestock transport vehicle to ensure that there are no spaces where the cattle can fall or break a leg. Buffers may include simple small vertical gates on either side to block the gap.

Catwalks

Raised walkways (catwalks) fitted to the ramp provide operators with safe access to cattle without having to climb fences. Catwalks can be located down one or both sides of loading ramps and along holding pens.

For safety requirements, catwalks should have a non-slip surface and be fitted with handrails to Australian standards.

Gates

Gates throughout the receipt and dispatch facilities provide access for cattle, handlers, truck drivers and machinery. Operator safety is also a major priority, allowing quick and easy access in and out of the forcing pen, lead-up race and ramp.

Design considerations for cattle and machinery gates are outlined in *Section 23 - Cattle processing*.

The truck driver needs access along the side of the vehicle for opening and closing both rear and baffle trailer gates. If an elevated walkway cannot be provided, a simple elevated rail would enable the driver to attach a safety harness. Truck driver access doors (about 800 mm wide) should only swing inwards to prevent personnel injury.



D-mould rubber front for cushioning impact, and slide gates behind the batwing gates.



Personnel catwalk along side of the loading ramp.



Swing out (batwing) gates and fully sheeted lead-up race and loading ramp.



WH&S inclusions on a loading facility sign, with railing and handrails on stairs for operator access



A gantry over parking area for a double deck livestock transport vehicle. Truck drivers would be attached via harness to the gantry for safe working on the top deck of the vehicle

Other design considerations are sliding/stop gates. Slide gates can be located either at the top or bottom of the ramp, preferably at the top with a double ramp. These slide gates also protect the truck driver when opening or shutting the tail gate; once the truck's tail gate is open, the slide gate can be opened from the ramp's catwalk.

For a dump ramp, a surging gate can be used at the bottom as it is too wide for a slide gate.

Lockable gates need to be considered to prevent illegal or unauthorised stock deliveries and removals and for quarantine measures.

The position of the loading ramp should not interfere with the functions of gates, races and other existing facilities.

Feeds to loading ramps

Race

The race leading up to the loading ramp is an essential part of the overall loading facility. It should hold the animals in single file and should be 680–760 mm internal width, depending on the size of the animals to be loaded out or unloaded.

A race in a receival or dispatch facility will have the same design principles as races in other on-site cattle handling facilities (e.g. processing, hospital). Further design detail on races can be found in *Section 23 - Cattle processing*.

A curved race encourages steady movement of cattle around the race whereas in a straight race, cattle will often move quickly forward, baulk and then try to move backwards. A curved race has a natural anti-backing effect and tends to be self-feeding.

A catwalk may be added to the race to elevate the operator to the right height to access cattle if persuasion is required to move cattle onto transport vehicles. This separation is desirable from a safety and operational perspective.

Forcing yards

Forcing yards offer a safe method with which to feed the races. More information on forcing yards and their operation can be found in *Section 23 - Cattle processing*.

Stacking pens

The receival and dispatch facility requires pens to hold the cattle after unloading and before loading.

These holding pens must be large enough to hold the largest group of animals required for handling as a batch, and lead directly into the forcing pen and race or loading ramp. These pens may serve for sorting cattle into dispatch lots, groups and/or quarantine pens for newly arrived cattle.

The size of the holding pens will be based on the number of cattle being worked. Each animal requires around 1.8 m² of space within the holding pen.

The pen must allow incoming cattle access to feed and water and outgoing cattle access to water.

If the cattle to be handled are originating from separate groups, it may be necessary to be able to subdivide the holding pen. Several pens should be built into the dispatch facilities to break cattle into livestock transport vehicle deck/pen sizes, rather than having one large pen for all animals. This makes loading safer and more manageable.

The race leading up to the loading ramp is an essential component of the overall loading facility.

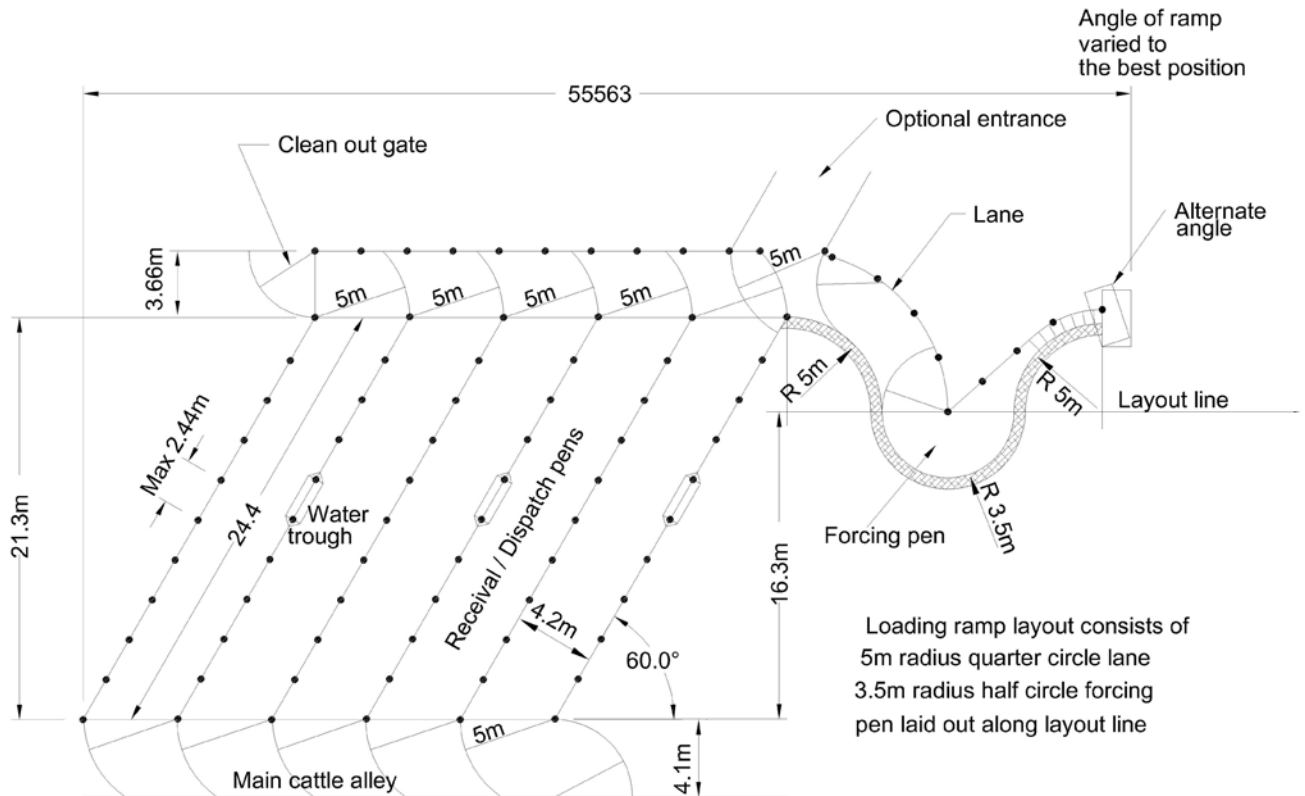

Figure 2. Layout of herringbone stacking pens

NFAS Standards provide minimum space allowances for transporting cattle of different weights (Table 1). This allows for the determination of the maximum number of cattle that can fit in the different types of trucks for transport to the abattoir (Table 2).

Table 1. Livestock loading densities

Mean liveweight (kg)	Minimum floor area (m ² /head) standing	Number of head per 12.2 m × 2.4 m deck
250	0.77	38
300	0.86	34
350	0.98	30
400	1.05	28
450	1.13	26
500	1.23	24
550	1.34	22
600	1.47	20
650	1.63	18
700	1.78	16
750	1.94	14
800	2.13	12



Stacking pens to hold cattle after unloading and before loading.

Table 2. Number of animals eligible for transport at different weights using different truck types

Truck type	Table top 1 deck	Semi- trailer 1 deck	Semi- trailer 2 decks	B double 3 decks	B Triple 5 decks	Road train 4 decks	Road train 6 decks
Floor area (m ²)	14.6	29.3	58.5	87.8	146.3	117.0	175.6
Animal liveweight (kg)	Number of animals						
250	19	38	76	114	190	152	228
300	17	34	68	102	170	136	204
350	15	30	60	90	150	119	179
400	14	28	56	84	140	111	167
450	13	26	52	78	130	104	155
500	12	24	48	71	120	95	143
550	11	22	44	66	110	87	131
600	10	20	40	60	100	80	119
650	9	18	36	54	90	72	108
700	8	16	33	49	80	66	99
750	8	15	30	45	75	60	90
800	7	14	28	41	70	55	83

Quick tips

- The receival and dispatch facility should be designed to provide a fast and efficient way to load and unload cattle on and off livestock transport trucks while providing a safe working environment for handlers and cattle.
- The functional elements contained within receival and dispatch facilities are largely independent of feedlot size.
- Poorly designed or maintained facilities can lead to confusion, stress and injury to both cattle and handlers.
- The basic element of facility design is to encourage good stock flow.
- Access and traffic flow of livestock transport vehicles are important when selecting the location of the receival and dispatch facility in the overall site layout.
- A firm and level pad in front of the loading ramps should be maintained to ensure an even unloading height and levelness of the trailer.
- Appropriate lights should be installed to prevent shadows, light blinding and bright spots which can spook or balk the cattle.
- A slight curve or deviation in ramp direction will utilise natural stock movement principles and improve the animals' willingness to move up the ramp.
- Ramp floors need to provide good grip, be easy to walk on, should not be slippery and should not resonate or create undue noise.
- Sheeting the sides of the lead up race and the loading ramp eliminates baulking from visual distractions, thus improving flow and preventing legs from getting caught.

Further reading

Animal Health Australia (AHA) (2012). Australian Animal Welfare Standards and Guidelines - Land Transport of Livestock. AHA, Canberra.

AUS-MEAT, 2014, NFAS Rules & Standards (April 2014), AUS-MEAT Limited, Brisbane, Qld.

Linden, N, 1994, Cattle Loading Ramps, AG0127 ISSN 1329-8062, Department of Environment and Primary Industries, Victoria, Australia.

DAFF, 2013, Australian Animal Standards and Guidelines for Cattle, Department of Agriculture, Forestry and Fisheries, Australian Government, Canberra, ACT.

Gahan RJ and Johnston BD Handling Cattle from Farm to Abattoir. Bulletin, NSW Agriculture, Orange

Gill, R. and Machen, R, n.d., Cattle Handling Pointers, Texas AgriLife Extension Service. College Station, Texas, Texas A&M System.

Gill, R. and Machen, R, n.d., Designing a “Bud Box” , Texas AgriLife Extension Service. College Station, Texas, Texas A&M System.

Grandin, T, n.d., Cattle Behavior During Handling and Corral Design for Ranches, Beef Cattle Handbook, Colorado State University, Colorado, BCH-9003.

Grandin, T, n.d., Livestock Psychology and Handling-Facility Design, Beef Cattle Handbook, University of Illinois, Illinois, BCH-9001.

Grandin, T – Livestock Handling from Farm to Slaughter, www.grandin.com.

MLA, 2012a, National Guidelines for Beef Cattle Feedlots in Australia. Meat and Livestock Australia, Sydney, NSW.

MLA, 2012b National Beef Cattle Feedlot Environmental Code of Practice. Meat and Livestock Australia, Sydney, NSW.

MLA, 2012, “Is it fit to load?” guide, Meat & Livestock Australia, Sydney, NSW.

NSW Government, 2005, Handling Cattle, Agfact A0.1.2, NSW Department of Primary Industries.

www.thompsonlonghorn.com.au

University of Arkansas, United States Department of Agriculture, and County Governments Cooperating, Cattle Working Facilities MP239

Worksafe Victoria, 2006; Beef Cattle Handling: A Practical Safety Guide, 1st Edition, Victorian Workcover Authority.



FEEDLOT DESIGN AND CONSTRUCTION

23. Cattle processing facility

AUTHORS: Rod Davis and Scott Janke

Introduction

All cattle arriving at a feedlot must undergo a process of 'induction' soon after arrival before being allocated to the production or feeding pens. Cattle that have travelled a long distance or that are stressed are first allowed feed and water and overnight rest to allow them to settle. All newly arrived cattle are observed for injury or impending disease, key details are recorded and treatments given, along with identification.

All cattle are then allocated a home production or feeding pen.

Over the feeding period, cattle performance may be measured. Once they reach their marketable weight and condition score, 'finished' cattle are dispatched from the feedlot to an abattoir.

A dedicated facility is needed to handle the cattle during the processes of induction, drafting (or selection) and dispatch. Induction and dispatch may be handled in separate facilities in a large feedlot.

The processing facility and associated equipment are designed to provide a fast and efficient way to handle and treat cattle and to provide safe working conditions for cattle and staff.

A processing facility typically includes

- holding pens
- forcing yards
- raceways
- restraint equipment
- drafting pens

A well planned processing facility allows cattle to flow smoothly while giving handlers convenient access, so that traceability, health and welfare and performance operations will put minimum stress on animals.

Design objectives

The processing facility should be designed, constructed and maintained to ensure that it

- accommodates the operations to be performed
- provides access to other handling facilities and production pens
- minimises stress and bruising on cattle
- maximises cattle welfare and worker safety
- addresses appropriate conditions for cattle and workers including temperature, shade, dust, noise, lighting, eliminating shadows, non-slip flooring, amenities, services and storage
- optimises vehicle traffic and cattle flow.

Mandatory requirements

Compliance with

- Australian Animal Standards and Guidelines for Cattle (DAFF, 2013)
- National Guidelines for Beef Cattle Feedlots in Australia (MLA, 2012a)



Aerial view of a processing facility and holding pens

- National Beef Cattle Feedlot Environmental Code of Practice (MLA, 2012b)
- NFAS standards (AUS-MEAT, 2014).

Design choices

All processing facilities are unique because feedlots can vary in scope and production targets. While an adequate processing facility need not be elaborate or overly expensive, oversimplification could make the facility difficult to operate.

No particular processing facility design can be considered the best. Design will vary with the type and size of cattle, number of animals to be processed, operations to be performed, space restrictions and personal preferences on facility layout.

The design of the facility should allow the operations to be performed, be safe, work well and allow cattle to be processed as efficiently and economically as possible. Cattle flow through a processing facility should be orderly so that sorting, weighing, and treatment will put minimum stress on animals and handlers.

The processing facility will include various associated components including forcing pens, races, cattle crushes, draft pens, weigh box, electronic equipment, catwalks, building and amenities.

Figure 1 provides a conceptual representation of the relationships between the various elements of cattle processing.

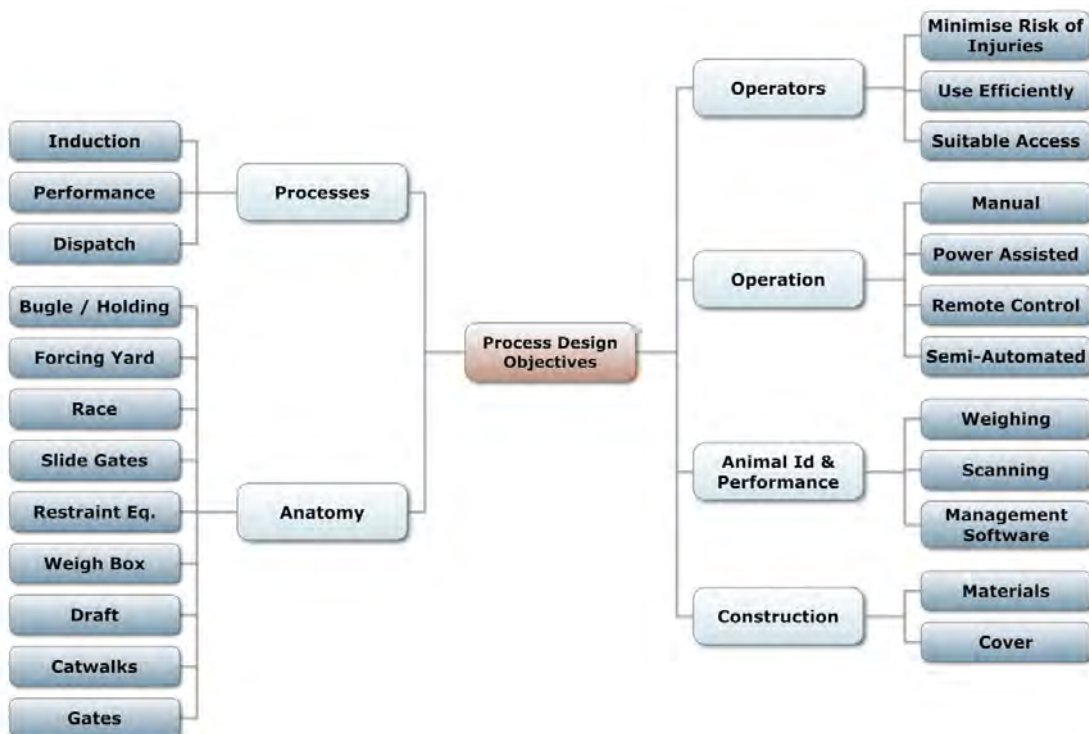
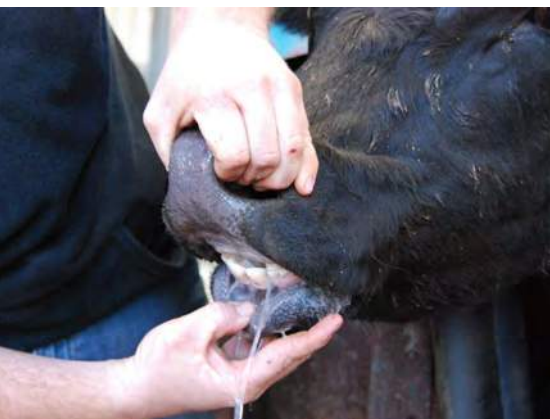

Figure 1. Conceptual representation of cattle processing design factors

A processing facility must be designed to

- accommodate the operations to be performed (e.g. induct cattle, weigh and/or draft cattle into groups, NLIS recording)
- handle the type and number of cattle to be processed
- give access to other handling facilities and production pens
- prevent injuries to cattle
- minimise stress on cattle
- prevent injuries to handlers
- consider size and shape of the components
- consider traffic and cattle flow to avoid cross overs
- ensure cattle flow smoothly by avoiding tight turns
- improve labour efficiency
- provide storage facilities for veterinary chemicals, ear tags
- provide amenities for people – first aid kit, personal protection equipment as required
- specify material type of construction (wood, steel)
- accommodate all-weather processing of livestock
- provide a cattle washing facility if required (see *Section 41 – Cattle wash facilities*).



Induction – age classification by dentition

Processes

Processing activities are generally combined to reduce cattle handling and improve labour efficiency. There are typically three stages of handling during the feeding period – induction, performance and dispatch.

Induction

The induction area of the feedlot must be designed to handle cattle in a safe and efficient manner. As some of the processes can alarm the cattle, low stress stock handling techniques and facilities will enable cattle to be managed in a more relaxed environment.

The processes of induction may include

- inserting and recording individual feedlot identifier ear tag
- NLIS scan of property of origin EID tag – refit if missing
- tail docking
- dehorning or tipping
- recording visual details
- weighing
- mouth dentition for age classification
- vaccinating, drenching and/or injections
- implanting with an HGP
- pregnancy testing
- health check
- classifying/segregating / drafting by sex, weight, age, type, cattle class, market specification or health observation



Induction – implanting an HGP

Performance

- scanning and weighing
- classifying/segregating/drafting based on performance to date
- health treatment
- re-implant of HGP
- health check

The performance process may be conducted multiple times or not at all.

Dispatch

- classifying/segregating /drafting by weight, market specification, market destination, or vendor
- washing muddy cattle
- scanning for loading out – individual cattle, withholding period (WHP) checks, export slaughter interval (ESI) checks, hormone growth promotant (HGP) checks, days on feed (NFAS) checks.

Features

The components of a processing facility are shown in Figure 2. Most systems implement similar equipment, but the main variations relate to the forcing yard and type of restraining crush. Other variations of the handling system may depend on which side of the animal in the crush faces the handler – near-side or off-side.

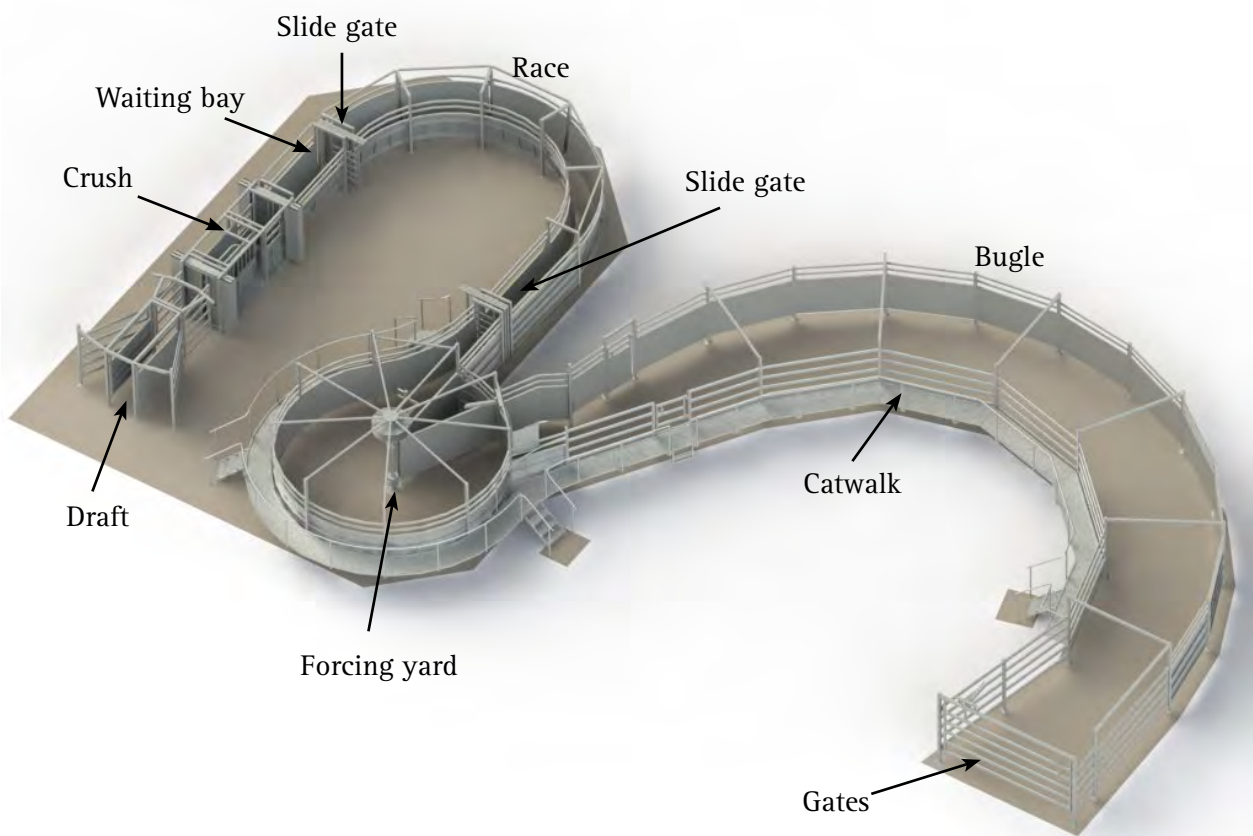

Figure 2. Components of processing facility



Complete handling centre with roof cover over crush area.

Bugle or holding pen

The bugle or holding pens hold cattle for a relatively short time before processing. Pens are usually joined in series, possibly with larger capacity additional pens off to the side. The holding pen size is typically for a single deck of cattle, which is generally an easier quantity to process at a time. This capacity will need to be able to fill the forcing pen and race, or just the race for feeding into the crush. The holding pens have direct access to the forcing pen (i.e. forcing pen/crush).

Well designed holding pens will help minimise bruises and stress. Long, narrow pens are recommended where livestock are held for a relatively short period of time as this gives efficient animal movement. With pens in series, handlers can control the animal's movements from outside the pens, usually from a catwalk alongside the fence. Narrow pens should have a maximum width of about 3 m.

The path or flow of the long narrow pens is commonly curved, hence the naming bugle (after the musical instrument). The pens are usually sheeted from the catwalk to separate cattle from handlers and on the outer fence line to prevent external distractions or baulking.

Forcing yard

A forcing yard is typically installed at a facility that processes a large number of cattle. A properly designed forcing pen decreases the labour required to work cattle and offers handlers a safe working environment.

The forcing yard is used to channel cattle into a race. Forcing pens can have a range of configurations; they can be either straight sided or circular.

Funnel-shaped forcing yards are less expensive and easier to construct than circular forcing pens, and this design may be appropriate for small feedlots. This design incorporates one straight side and the other side entering the race at an angle of approximately 30 degrees.

A straight-sided forcing yard is easier to build into an existing set of pens, but a circular forcing pen (Figure 3) should be considered if the facilities are being extensively rebuilt or new facilities are being constructed.



Forcing pens (bugle) with slide gates and catwalk with safety handrail.

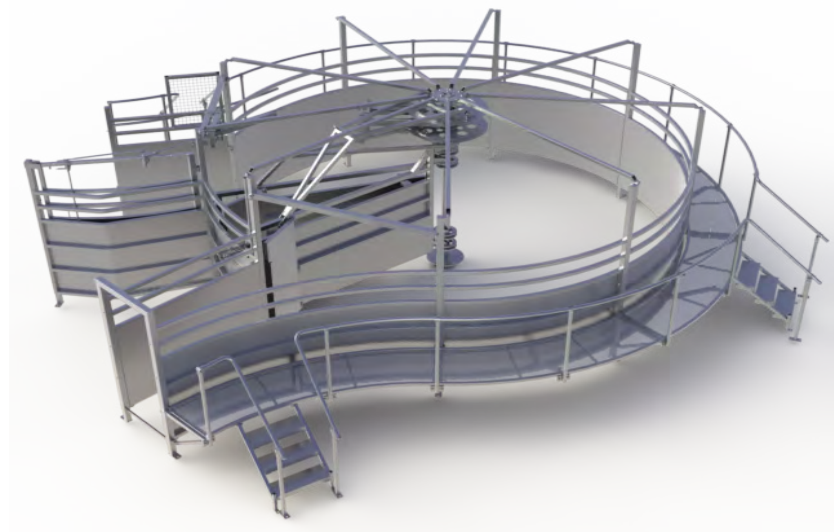

Figure 3. 3-D schematic of a circular forcing pen

Typically, forcing yards are a small circular yard. A cattle 'talker' or 'flapper' is used to reach all animals from outside the forcing pen, or a centre swing gate is used to reduce the size of the excess yard space. The forcing yard can be a full circular or semi-circular shape – anywhere from 180° to 270°. The size of the forcing yard is important as too large a forcing area makes it difficult to effectively coax cattle from the catwalk. The circular shape helps encourage continuous flow by taking advantage of the natural behaviour tendency of cattle to return to whence they came and circle around the handler. However, this circling can raise the arousal level of the cattle making them more difficult and dangerous to handle (*Section 21 - Livestock handling*).

The sides of the forcing yards are generally sheeted to prevent cattle from seeing workers or other cattle out of the pen, and baulking.

The forcing yard must be designed so that cattle can be easily moved into it from the holding pen and then be easily guided into the race.

Sight between the forcing yard and the race is important. The cattle in the forcing yard should be able to see at least one body length up the race. If they cannot see into the race or are distracted, cattle will hesitate or refuse to enter without persuasion, adding pressure and stress.

A centre-swing gate is used to remove excess space, preventing cattle circling in the forcing yard. This also encourages the cattle to think that the exit of the forcing area is a way of escape. The centre-swing gate should be sheeted to prevent cattle from seeing people or other cattle and baulking.

Centre-swing gates can be **pneumatically** or **manually** driven. The gate can be designed to latch at various positions as it closes, or backstops can be used. Backstops allow handlers to move the gate and not have to worry about locking it. An automatic, self-locking latch or backstops on the centre-swing gate can speed up movement of cattle through the forcing yard. These systems also increase safety by preventing cattle driving the gate in reverse and injuring the handlers.

Continuous operation, whereby the centre gate does not need to be reversed before refilling the forcing pen, may be achieved with a fully circular forcing yard fitted with double pneumatically driven centre-swing gates. In this design, when one centre-swing gate has completed a full rotation, the other is activated and rotates behind the next group of cattle.

Cattle that have already been processed with a circular forcing yard at least once are generally used to its operation and will flow through— often without needing to use the centre-swing gate.

Major design problems with forcing yards are inadequate swing gates or no swing gates, and a failure of the forcing yard design to channel cattle into the race. Poor drainage and mud accumulation can cause poor footing in the forcing pen, with cattle baulking and being more difficult to work. The forcing pen surface should be compacted, well-drained and well maintained. A concrete slab with non-slip surface will maintain good footing in the forcing pen but soft flooring may also be used. See *Section 22 - Receiving and dispatch facilities*.



Circular forcing yard and cattle flow.



Hydraulically-controlled gate

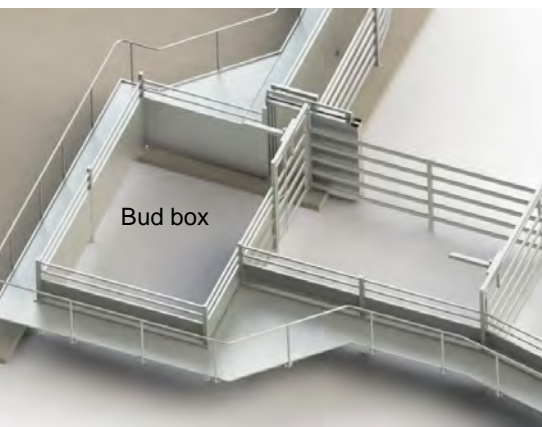

Figure 4. 3-D graphic of Bud Box

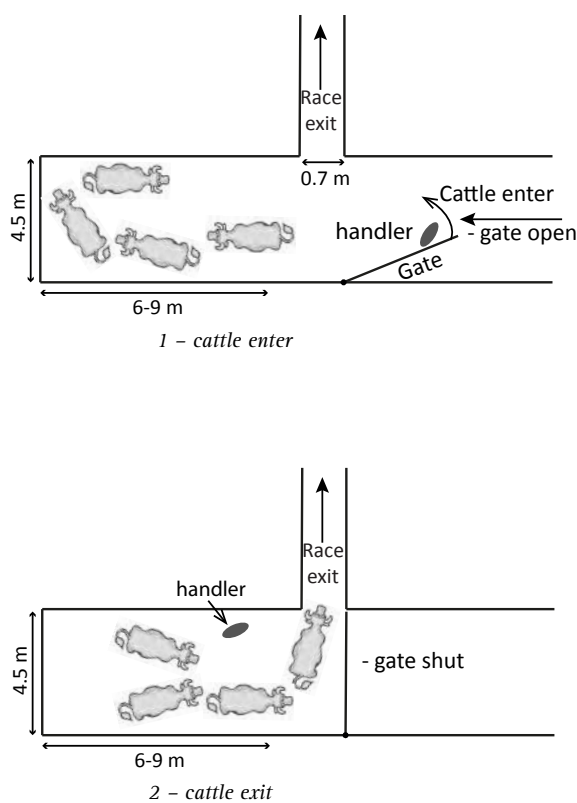

Figure 5. Basic Bud Box design and operation

Bud Box

The decision to incorporate a Bud Box or a crowd pen in the facility is a matter of personal preference.

A Bud Box is simply a small rectangular pen that replaces the traditional half-round crowd pen to move cattle from the holding pens to a race (Figure 4). It is named after Bud Williams, an American pioneer of low stress livestock handling.

Bud Boxes rely on the natural behaviour of cattle in that they want to go back the way they came. When cattle enter a Bud Box and reach the dead end, they naturally turn back. At this stage, a gate is swung across the entrance side of the pen, and cattle are directed to the adjacent race exit by the handler in the box (Figure 5).

The box is a flow-through part; cattle are brought in and then let flow back out immediately. Cattle should never be held in the Bud Box.

An advantage with the Bud Box is that it is built as a rectangle with 90° corners making construction simpler than curved yards. The entrance to the single file race should not be V-shaped; a square opening allows cattle to enter in single file without getting blocked and then retreating.

Dimensions of the box (length and depth) are determined by the size of the group handled and then by the capacity of the race. The box needs to be deep enough to allow cattle to flow forward while the handler closes the swing gate and gets into position before the cattle move towards the race. The race should be long enough to hold an adequate number of cattle for processing or loading, and be straight for at least two body lengths to encourage entry.

Table 1. Dimensions for a Bud Box

Bud box dimensions		
Handler	Width (m)	Depth* (m)
Always on foot	3.7	Minimum 6
Afoot and horseback	4.3	6-9
Always horseback	4.9	Maximum 9

*Depends on size of groups handled

The end of the Bud Box should not be enclosed so that cattle see light again and enter the box without baulking. Solid or opaque panels should be limited to the Bud Box’s entry gate and the side closest to the race.

A disadvantage of the Bud Box system is that the handler has to be inside the box with the cattle to close the swing gate and then to be in a position that encourages the cattle to move naturally to the race exit. The handler may be mounted on horseback but if on foot, has no easy escape route should an aggressive animal approach. This becomes a Workplace Health and Safety issue.

Race

A race is a narrow lane to single file cattle for further processing, batch treatment or visual inspection. When used as a feeding or indexing unit it can be used in conjunction with crushes, weigh

boxes, scanners, loading ramps or drafts. A race is usually located before a crush or draft and best filled by using a circular forcing pen.

Cattle are forced into **single file** to direct them towards the crush or weigh box, and to overcome their natural instinct to return to where they came from. The aim is to maintain a **constant and continuous flow** without involving many workers in the process.

Races are typically curved, but can be straight. A curved race gives the cattle the impression that they are returning to where they came from (Figure 6), and gives a more steady flow, whereas long straight races tend to speed the cattle up.

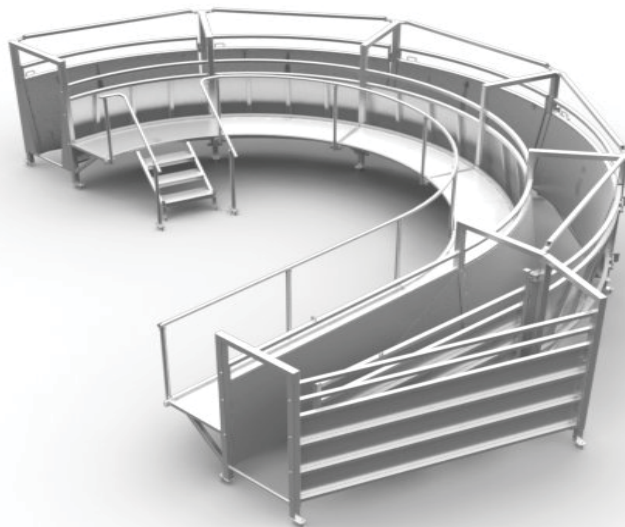

Figure 6. 3-D graphic of a curved race

However, the race needs to be straight for at least two animal lengths at the start, as an immediate curve would look like a dead-end to the lead animal. Once in the race, cattle are content to follow the curve if followed or pushed by others.

Another advantage of a curved race is that the person operating the race can walk directly across from the forcing pen to the restraint equipment without inhibiting cattle flow; this is helpful if the same person is working both the race and restraint equipment.

To obtain and maintain a single profile of cattle the race needs to be narrow, but the optimal width will depend on the size or age of the animals. Too wide a race allows small cattle to turn around or all cattle to put their heads down beside the animal in front; too narrow a race will constrain large cattle and restrict their flow. The width and height will depend upon the breed and class of cattle being handled – widths can be between 660 mm and 760 mm of clear space. The most suitable race width will balance cost against the degree of prevention of animals turning around.

The race length will reflect the number of cattle being handled – about 1.6–2.4 m per adult beast is adequate.

Races may be parallel-sided, V-shaped or with adjustable width. A V race accommodates a diverse range of cattle sizes and weights



Straight race sections with split slide gate. The section before the crush is a waiting bay.



Curved V-race with full sheeting on the outer wall and half sheeting on the inner wall.



Parallel curved race with no inner sheeting.



Curved V-race with full inner and outer sheeting and a catwalk with safety handrail.

by restricting leg room but allowing adequate room for their upper bodies. Curved V races must have conical inner and outer panels; curved parallel-sided races need rolled radius panels to provide a constant width all the way round; a truncated race varies in width. An adjustable race has one side adjustable from a remote location to accommodate various cattle sizes and weights.

Sheeting the walls of the race to block out distractions focuses the attention of the cattle on the preferred way out. The outer panel of the race is normally fully sheeted to aid good livestock flow by overcoming external visual distractions that will baulk and frighten them. Sheeting of the inner panel is largely determined by the type of operations to be performed.

A **fully-sheeted inner race** favours tasks where back applications are performed as it can have a catwalk along which cattle cannot see the handler.

A **half-sheeted race** does not have a catwalk but allows cattle to see the handler to control flow by standing at their sides. Half-sheeting also allows side access to livestock while reducing the risk of being kicked through the lower rails. A **non-sheeted race** is best where lower portions of the animals (the underside, legs or hooves) are to be inspected.

Break-out gates in the outer panels of the race help quick removal of an animal that goes down, and allow cleaning inside the race. Break-out gates should be fitted with latches that make them quick and easy to open and close while providing secure rattle-free operation.

There are variations and options on the single-race design including a waiting bay for crushes, weigh boxes, anti-backing gates, dual race, split race and load out gate configurations.

A dual-race configuration typically has two fixed-width races side by side and sharing a common non-sheeted panel. This race is used to feed a single process (such as a crush) but helps improve cattle flow as one race can be loaded whilst the other is being emptied. A split race is two races with a splitter gate that can feed two processes; it is used in large operations that require double the throughput or where separation is required for two specific processes.

Slide gates

Slide gates are sideways sliding gates installed in races (Figure 7). They are used to prevent cattle backing (as a manual backstop) or to help separate animals when indexing into a crush or draft.

Slide gates may be manually operated or power-assisted (usually pneumatic), and either solid (single gate) or split slide (two gates). For power-assisted gates, guarding is required for personnel safety. The gate itself may or may not be sheeted.

Slide gates can be placed between the forcing pen and race, race and weigh box, crush and draft. A solid slide gate is typically used between the forcing pen and race as a backstop to keep animals in the race. With a catwalk, a solid gate is used that slides away from the handler, whereas the guard on a split slide would interfere with the catwalk. A split slide is commonly used between the race and weigh box as this allows quick separation of the animals – catwalks

around this slide gate are widened to accommodate the guarding. Slide gates for a draft are used to prevent animals returning back up a draft when not in use for a time (e.g. during a workers' break). These are typically a manual gate.

Cattle restraint equipment

All cattle have to be restrained in a cattle crush for safe examination or treatment at some time during processing.

All feedlots should have a purpose-built crush which allows all-round access. Important features include quietness, strength, safety for animal and handler and positive operation from behind the animal. *Section 25 - Cattle crushes* provides further discussion.

Weigh box

A dedicated single-animal weigh box may be integrated into a processing facility to speed up processing or for accurate weighing of individual animals. A bulk cattle weighbridge may also be used for large groups of animals. See *Section 27 - Truck weighbridges*.

Weigh boxes are walk-through design, typically 2.8 m long and 660–760 mm wide inside, and can be setup for automatic operation (with gates and identity scanning). They are usually located immediately before the cattle crush.

Drafts

Cattle will have to be sorted into groups as an integral part of feedlot management.

The number of animals to be drafted usually determines the type and configuration of the drafting system. A drafting system may be operated manually, be power-activated using remote control or fully automatic (Figure 8). The number of drafting pathways will depend on local requirements.



Figure 7. 3-D graphic of a slide gate



Cattle crush for restraining animals in the race.



Figure 8. 3-D graphic of a 3-way draft



Suspended weigh box and NLIS race reader.

The drafting system is best located in the processing area, a short distance away from the crush and connected directly to the various holding/drafting yards.

For smaller-sized feedlots, the drafting system may comprise a circular pound centrally located. The circular pound would have a number of sides with associated gates to holding pens. This allows for one person drafting and the transfer of cattle anywhere through the facility.

Automated systems that are affordable and can work accurately and consistently will reduce stress on handler and cattle by improving the flow of activities. Consistent cattle flow is critical to the success of automated drafting.

Automated drafting systems consist of a short race, sorting gate, drafting pens and an identification system and controller. The gate can be actuated by electric motor, pneumatically (pressure or vacuum) or hydraulically (water or oil) and can be operated by a system controller or by remote control. The drafting system allows the controller to communicate with the drafting unit; automated systems are equipped with a manual override in the event of a malfunction.

Automated drafting may require electronic identification of the cattle (e.g. NLIS). The NLIS technology should be fully integrated and compatible with the NLIS requirements of the processing system.

Some systems require each animal to be stopped for accurate identification whereas others allow a constant walk-through with animals being identified as they pass by a remote sensor. The system will affect cattle flow from the processing area.

Race design, animal travel paths and holding pen location all require careful consideration if the automated drafting system is to be a success. The lead-up race should be a minimum of two animals in length (4000–4800 mm) and a constant single animal width (760–820 mm).

Variations to cattle travel paths should be minimised, with the drafting path being the same as the exit path. Holding pens that are parallel with the exit race will also assist cattle flow.

Many systems allow the drafting criteria to be tailored for the feedlot, thereby allowing individuals, groups of animals or any animal meeting a particular criterion to be drafted. This feature can remove or reduce the need to program the drafting requirements just prior to each activity.

Several gate designs are used in automated drafting systems (Figure 6). They include single gates, where one gate is moved to switch the animal path from exit to holding pen, and twin gates, where two gates are moved in counter directions to switch the animal path.

Animal path variation can be minimised by good gate design. The 'straight ahead' or 'out the side' choice has more options than a system using a left or right choice.

The drafting gate must activate fast enough to draft the desired animals without catching those not required. Cattle must not be able to force the gate and get jammed. The drafting system must be constructed to withstand the rigours of cattle handling.

Cattle like to follow one another by sight and the drafting gates should ensure good forward visibility to encourage cattle flow. Poor visibility and noisy operating actions can interrupt flow.



Pneumatic 3-way fan draft

Catwalks

Catwalks provide a continuous and unbroken path between the forcing yard, race and cattle crush, especially in large operations. They put a handler at the right level to coax any unfamiliar animals into the right direction in the forcing pen, and can be used for applying backline treatments.

A catwalk along the race saves handlers from having to continually get up and down from the forcing pen catwalk and for crush handlers who are also required to control the race.

A catwalk typically has step access at the entry and exit ends. Interim steps allow a handler to get onto the catwalk without baulking the first few cattle that are ready to enter the race.

Handrails meeting WH&S requirements must be fitted if the catwalks are above the minimum distance of 300 mm. More details are specified in Platforms as per the Australian Standard AS1657.

Catwalks should have a minimum width of 600 mm, but be wider in areas where two workers commonly have to pass each other.

An alternative to a catwalk is to have a section of raised concrete that acts as a platform from the forcing yard across to the cattle crush. This provides easy and safe access for one or more operators to all activities in the processing area.

Gates

Gates allow livestock, people and/or machinery to enter and exit any component of the processing facility.

A gate acts like a panel when closed and can be swung, slid or lifted to allow access. Typically, one end of a gate has hinges while the other has some type of latching mechanism to restrain it in either the open or closed position. Poorly hung or designed gates and latches can make cattle work more difficult and increase the risk of injury to the handler and animals.

Gates are normally located in the corners of pens for ease of livestock flow. They vary in length and width depending on the application and desired outcome. A narrow gate of 500 mm gives personnel access and safety, but wider gates are needed for cattle and even wider for machinery access. Access for machinery may be made by way of two gates used together to create a double gate (gate latches to gate) or by using a removable centre post.

Gates are usually made of similar materials and construction as in the surrounding fence panels (e.g. oval steel, round pipe, RHS), and constructed to withstand impact by livestock.

Gates should swing freely and the top hinge gudgeon should be reversed or pinned to prevent gates being lifted off.

Operation

Depending on the throughput and number of people involved, the processing area can be operated manually, power-assisted, remote-controlled or semi-automated.



Catwalk on bugle yard



Solid slide gate



Power-assisted hydraulic gate



Power-assisted pneumatic gate

Manual

Manual operation has the lowest setup cost and does not need power to operate, but a handler has to walk to each piece of equipment to operate it.

Power-assisted

Power assistance can be pneumatic or hydraulic. Pneumatic systems are cheaper but may need a secondary brake or catch to hold the equipment in its final location. Air power may also need an exhaust system on each piece of equipment to reduce noise. In a remote yard, a pneumatic system using an engine-powered air compressor can be located away from the yards so noise does not interfere with the operations. Air is clean, safe and does not necessarily require experienced personnel or specialised equipment to maintain it. Hydraulics generally offer more power, are slower, quieter, but may require 3-phase power and are generally more expensive. Hydraulics will require specialised equipment and personnel for maintenance, present risks with hot, high-pressured oil and, if they leak, can be messy.

The crush is usually the first item where power assistance is added. Other pieces of equipment that can be power assisted include

- crush – head bail, squeeze
- slide gates
- draft gates
- forcing pen and entry gate
- lane gates
- adjustable width race

The installation of power assistance will depend on frequency of use, the physical effort needed to operate and ease of access.

Remote controlled

In a remote-controlled operation, power-assisted equipment can be controlled from a hand-held remote from any location in the processing area. This is useful around the race and forcing yard areas where the handler uses his position to control the movements of the cattle (refer to *Section 21*) and the remote for the gates.

The hand-held remote communicates with a control box which instructs the powered equipment using solenoids. In remote locations, a control box can be powered using a 12V battery.

Semi-automated

Semi-automation is used in systems that require simple repetitive tasks like weighing and/or drafting. It reduces the labour requirement in this area and optimises operational speed.

The system is used where an animal's weight is recorded, a draft decision is made, a draft gate opened to the appropriate pen, and the head bail on the crush is opened to release the animal to this pen. Once the weigh indicator of the crush zeros, the head bail is closed and the rear bail opens for the next animal. The rear bail is then closed by a handler to ensure only one animal enters the crush at a time. With the rear bail closed, the system repeats its cycle.

A computer is connected to the control box, load cells and scanner which records weights and makes draft decisions. Decisions can be made on weights or animal ID.

Handler safety

Worker safety must be accommodated as handlers working with animals are exposed to a range of injury hazards. A handler must be able to move safely from one part of a facility to another and be able to easily move to safety if a dangerous situation arises.

Minimising risks of injuries

The level of injury to a handler may range from death, serious injury requiring hospitalisation and down time, to 'nuisance' injury that stops work for a short time or makes work slower and less productive.

Some of the best practices are to separate animals and workers, while allowing workers to control cattle and perform required treatments. In the pens, the use of horses helps create this separation.

Documenting processing procedures helps handlers remain aware of their actions, safety and the importance of the need for this separation.

Efficiency

As the number of available skilled livestock handlers declines, feedlots have to operate with fewer people, and this must be considered in design.

Efficiency can be increased by reducing walking distances and using power assistance and automation. Most layouts incorporate curved races to hold animals, and locate major components such as crush and forcing pen closer together.

Power-assistance helps reduce handler fatigue when processing large numbers of animals. Automation can help make the decisions that someone would have to make crush side, and also supports specific applications such as drafting by weight, drafting by ID and live weight recording.

Documenting processing procedures also helps improve efficiency as it can define the role of each handler and how each piece of equipment is best operated. Procedures can be easily updated if a more efficient method is found, and they are useful in training new handlers.

Suitable access

Access for handlers helps reduce walking distances and improves efficiencies.

A plan with projected walking and driving paths helps identify the best locations for access gates. Paths to be identified in process documentation include those from vehicles to amenities, access during processing procedures, processing area to pens and for cleaning and maintenance. Where lanes or areas may sometimes be used for cattle, over-passes that do not affect animal flow could be considered.

Appropriate signs and warnings are required at access points where visitors or external personnel have access to the site.



Pneumatically-swing gates used in stacking pens.



Controls for operation of gates from hand-held remote.



NLIS and visual management identification tags



Automatic NLIS tag reader on cattle crush

Animal identification and performance

The National Livestock Identification System (NLIS) and advances in the automation of cattle handling activities foster development of associated electronic equipment and system controllers. These can identify specific cattle and measure their performance based on weight gain.

An equipment control unit (with power-assisted items), weighing unit, scanning unit and computer with herd management software can be installed. In small operations, these may be separate units requiring some manual operation and data transfer – taking time and the risk of human error – although they can be connected to communicate with each other to record data and calculate decisions.

NFAS requires all animals to be fitted with both a NLIS tag and a visual management identification tag.

Weighing

Weighing of animals should be incorporated into the facility design. Electronic equipment for accurate weighing will need to have dedicated processes and may also be integrated with the cattle management system. An automated drafting system integrated with the cattle management system allows cattle to be drafted automatically on criteria such as weight and market specification.

A weighing unit usually consists of load cells and a controller. This controller converts a signal from the load cells into a weight, and handles the calibration of the load cells (calculates tare weight) to display an animal's live weight. More advanced controllers can also make weight and drafting decisions which can communicate directly with the equipment control unit to operate drafting gates.

Scanning

The technology required for scanning and recording NLIS devices has to be integrated into the processing facility design. The choice of a simple system or an advanced system that uses the technology as a management tool will depend largely on the size of the feedlot.

Scanning manually uses a hand-held scanner that will display the NLIS ID of each animal. For automatic systems, a scanning unit can be fitted to the non-working side of the crush or weigh box.

Herd management software

In a processing area, all units connect to a central computer running software for the collection of data and for decision making. Data from this computer can be transferred either manually (disk or USB) or over a network/wireless connection to the main office.

Construction

Materials

Any combination of materials can be used in the construction of the processing facility, with the choice depending on local availability of materials and budget constraints. The key design criteria will be to balance strength, durability and construction cost.

Corrosion is a major consideration if wash-down water has high salt content. Construction material types and surface metal finishes can help inhibit or reduce the rate of corrosion.

Mesh and cable fence panels should not be used in the race and forcing pen areas.

Materials used in the construction of the yards, flooring of the processing facility and infrastructure are similar to that of receival and dispatch facilities. Design considerations for materials are outlined in *Section 22 - Receival and dispatch facilities*.

Protection from the environment

All or a part of the processing facility may need protection from the weather. More information on this topic is covered in *Section 24 - Buildings*. Flooring, drainage and other amenities are also described.

Quick tips

- All processing facilities are unique. An adequate processing facility need not be elaborate or overly expensive, but oversimplification may make it more difficult to use.
- An excellent design on one feedlot may not work as well on the next – spend ample time planning before building. If possible, visit other feedlots to see what works well and what does not.
- A properly designed forcing pen decreases the labour required to work cattle and offers handlers a safe working environment.
- Holding pens are used to hold cattle for a relatively short period of time before processing. Long, narrow pens provide more efficient animal movement than squarer pens.
- A curved race takes advantage of an animal's natural instinct and gives the cattle the impression that they are returning to where they came from.
- The technology required for recording NLIS devices should be integrated into the processing facility design.
- The accurate drafting of cattle into groups is an integral part of the feedlot cattle management system.
- Noisy operating actions and poor directional visibility can interrupt cattle flow.
- Catwalks provide a continuous and unbroken path between the forcing pen, race, and cattle crush, especially in large operations, and place the handler at the right level to coax any unfamiliar animals in the right direction.
- Poorly hung/designed gates and latches can make cattle work more difficult and increase the risk of injury to the handler and animals.
- Operating the processing facility with minimal labour is a key design consideration.
- NLIS and advances in automation of activities require various associated electronic equipment and system controllers.
- An automated drafting system integrated with the cattle management system allows cattle to be drafted automatically on pre-set criteria.
- Mesh and cable fences should not be used in the race and forcing yard areas.
- All or a part of the processing facility could benefit with protection from the weather.

Further reading

Grandin, T. and Deesing, M, 2008, Humane Livestock Handling, Thomson-Shore

Blackshaw, J. (1986), Notes on some topics in applied animal behaviour, University of Queensland, St. Lucia. <www.animalbehaviour.net>

Herve, J. Szentleki, A. and Tozser, J. (2007), Cattle's behaviour – Perceptions, relationships, studies and measurements of temperament, Animal Welfare Ethology and Housing Systems, Volume 3, Issue 1, Godollo.

Smith, B. (1998), Moving 'em: A guide to low stress animal handling, Graziers Hui, Hawaii.

Grandin, T, 2008, Livestock Behaviour, Design of Facilities and Humane Slaughter (www.grandin.com)

Bud Williams Stockmanship School (www.stockmanship.com)

agrifecdn.tamu.edu/beefinfo/files/2014/01/Designing-a-Bud-Box.pdf

Daniels bud box demonstration www.youtube.com/watch?v=o58f4_uNbxo

Animal Health Australia (AHA) (2012). Australian Animal Welfare Standards and Guidelines - Land Transport of Livestock. AHA, Canberra.

AUS-MEAT, 2014, NFAS Rules & Standards (April 2014), AUS-MEAT Limited, Brisbane, Qld.

DAFF, 2013, Australian Animal Standards and Guidelines for Cattle, Department of Agriculture, Forestry and Fisheries, Australian Government, Canberra, ACT.

MLA, 2012a, National Guidelines for Beef Cattle Feedlots in Australia. Meat & Livestock Australia, Sydney, NSW.

MLA, 2012b National Beef Cattle Feedlot Environmental Code of Practice. Meat & Livestock Australia, Sydney, NSW.



FEEDLOT DESIGN AND CONSTRUCTION

24. Buildings over processing facilities

AUTHORS: Rod Davis and Scott Janke



Portal frame pitched roof structure over the crush area only.



Steel and timber roof over crush, race and handler working area only.



Steel frame structure over crush with half-sheeted walls. Sharp contrast between dark shadows and bright sunlit areas could make cattle baulk.

Introduction

Locating a livestock handling facility inside a building, or covering part of the handling facility, improves the environment for both cattle and handlers who can work during inclement weather in a timely and low stress manner.

The most important work places to cover are the race and crush area. Electronic or electrical equipment may need to be housed in a dedicated, relatively clean area.

Design objectives

Buildings for livestock handling should be designed and constructed to

- Provide protection from the weather.
- Cover the area over the crush and preferably the entire curved race area.
- Have functional space for livestock handling processes.
- Maximise cattle flow and minimise baulking of cattle.
- Provide a safe, well-lit and ventilated working environment.
- Be able to be cleaned and hosed easily.
- Provide storage of equipment and veterinary chemicals.
- Provide storage of electrical equipment associated with operations.
- Comply with respective state building codes and relevant Australian Standards.

Mandatory requirements

Compliance with

- Australian Animal Standards and Guidelines for Cattle (DAFF, 2013)
- National Guidelines for Beef Cattle Feedlots in Australia (MLA, 2012a)
- National Beef Cattle Feedlot Environmental Code of Practice (MLA, 2012b)
- NFAS standards (AUS-MEAT, 2014).

The building elements, such as concrete footings, floor slabs and steel structures, shall achieve the structural provisions of the Building Code of Australia (BCA) and local building regulations and be designed in accordance with the relevant Australian standards.

Design choices

A functional structure need not be elaborate or overly expensive. Suitable designs will vary according to: the number of animals to be processed, operations to be performed and when they are to be performed; space restrictions; local weather; personal preferences; and budgets. The structure covering the processing facility should be determined during the planning and design phase of the project.

Types

The size of building can vary from one that covers the crush only to one that covers the entire processing area, including forcing pens, curved races, crushes and the draft area. Typically, small structures are free standing with a skillion or pitched roof and no walls. Larger facilities may be similar to a more commercial building, with walls, offices, staff amenities and storage facilities.

Section 40 – Machinery Workshops illustrates structural design elements of buildings that may be used as covers for processing facilities.

Structural design

The structural design criteria for various elements of a processing facility building are similar to other structural elements around the feedlot, such as steel structures in machinery workshops (see *Section 40 – Machinery workshop*), concrete footings, foundations and floor slabs in grain commodity storage areas (see *Section 28 – Feed preparation and commodity storage* and *Section 31 – Commodity storage*) and vehicles (see *Section 42 – Vehicle washdown* and *Section 41 – Cattle wash*).

Environment

Sun and heat

Solar radiation and heat are a major reason for protecting workers and cattle during processing.

Ventilation through roof vents is needed to prevent heat buildup in walled buildings. Skylights or clear roof sheeting will enhance natural lighting during the day, but can allow direct radiation.

Walls and roofing can create shadows that may baulk the animals (see *Section 21 – Livestock handling*) in the early morning or late afternoon. Sun angles can be calculated at both ends of the day during summer and winter to assess invasive bright light or shadows cast from structures. *Section 16 – Shade* provides more information about calculating shadow cast.

Rain

Protection from rain helps prevent interruptions during processing. Rain from roofing should be collected with guttering and directed away from the facility into the standard feedlot drainage system. Roof run-off is likely to be contaminated with manure dust and is not suitable for drinking.

Without gutters, water running off the roof into the flow of animals can cause cattle to baulk and create an unpleasant working environment if it flows through the processing area.

Wind

The direction of the prevailing wind will determine which walls should be clad and the orientation of the building. One or more walls can be left unsheeted for ventilation and to reduce costs. Air flow is important to maintain building ventilation, but wind will drive dust and rain and generate a chill factor in colder climates.



Steel frame building over entire processing area. One third of the shed is fully enclosed for storage and two side walls are half-sheeted from the top for protection against rain and wind. The north-facing wall is not sheeted.



Steel frame building over the entire processing area. It is partially enclosed for protection against rain and wind, with a roof vent for ventilation.



Steel frame building over entire processing area. Lighting is provided with clear roof sheets and artificial lamps.



Stamped concrete with square pattern aligned along direction of flow. The lack of grooves on left where cattle turn is not ideal.



Stamped concrete with continuous square pattern orientated at 45° to cattle flow.



Stamped concrete with herringbone pattern.

Flooring

The floor level of the processing facility needs to be higher than the surrounding area to allow drainage of cleaning water out of the building.

Flooring within the processing facility should be non-slip, easy for cattle to walk on and not cause a hollow noise. The surface on which the animals walk has the greatest influence on any possible injuries. Worker-only areas do not need the same traction requirements as the cattle areas.

Any combination of materials can be used in the construction, with the choice depending on local availability of materials and type of flooring required.

Floors that receive heavy pressure from stock – such as gateways, forcing pens, races and the cattle crush – are generally constructed from concrete. But there is an increasing trend to using soft flooring options.

Concrete

Well designed concrete surfaces can provide a comfortable, clean environment, provided the correct falls allow good drainage during cleaning. But concrete floors can develop potential trouble areas over time, including the following issues

- Broken, cracked, eroded or otherwise damaged surfaces can lead to foot problems, such as sole bruising, or be responsible for small wounds that can allow infection to enter the foot.
- Poorly designed or constructed concrete surfaces may not provide sufficient grip for cattle. New concrete should be well compacted to minimise wear during its lifetime.
- Worn concrete can be particularly smooth and slippery and can lead to sole bruising and foot and leg injuries.
- Poorly constructed and damaged floor areas generate pot holes and dips in which manure collects, they are difficult to clean and could be a source of infectious illness.

There is little industry consensus regarding the most appropriate dimensions, orientation and configuration of grooves or patterns installed in concrete to create a slip resistant floor.

Theoretically, a floor that provides confident footing should have

- Parallel grooves spaced 40mm apart
- Grooves with a maximum width of 10mm
- Grooves across the animal's path of direction
- A regular pattern of hexagons with sides of 45mm in length.

Patterns in concrete can be created by grooving or stamping in green concrete, or cutting after initial curing takes place.

Grooves in green concrete

Bullfloating is a standard task that is performed after screeding when constructing concrete slabs-on-grade. Groove moulds are simply added on a bull float from plywood or wood strips. Bullfloating grooving is suitable for small areas and produces grooves without sharp or rough edges or exposed aggregates.

Diamond and hexagonal patterns can be created in green concrete using a metal stamp. Typically the stamp is fabricated from metal cut and welded together and with a handle, allowing it to be pushed into and removed from the concrete surface.

Stamping is sensitive to concrete moisture conditions. Concrete that is too wet will tend to stick to the stamp, causing undesirable rough edges and a 'sloppy' finish. Concrete that is too dry will bulge up in the inner space between each member used to form the pattern.

Cut grooves in cured concrete

New concrete floors can be grooved after initial curing and older concrete floors can be re-grooved as needed. Cutting grooves in hardened concrete eliminates the need for contractor experience in grooving wet concrete and the timeliness of stamping and bull floating.

Soft flooring

Soft flooring is becoming more common as feedlots seek to improve cattle welfare and minimise slipping and hoof/limb injury. The quietness of soft flooring also reduces cattle stress and assists with cattle handling.

The most common form is rubberised, high friction soft flooring that is available in mats or rubber belt form.

Rubber belting is usually reclaimed from the mining industry, where it is typically used as conveyor belting. But widths are usually limited to about 1800mm. Reclaimed rubber belting might have different levels of hardness and wear.

Rubber belting can be cut into various widths and lengths to meet particular needs. Belting should be fastened down with slightly countersunk, corrosion resistant fasteners embedded in the concrete. Grooving, or a pattern of holes, in the belt material is essential - as urine and manure make non-grooved belting slippery. Typically, holes of about 40mm in diameter are punched along the entire length of belting.

Suspended mesh

Woven wire mesh suspended over a concrete floor can provide a non-slip surface, with manure and urine falling through the mesh and simplifying cleaning processes.

Mesh flooring can be suspended at various heights above the floor. Typically the mesh is attached to the top of aluminium stirrups of about 100mm in height, but it must be well supported to prevent bending. This type of flooring is more common in abattoirs, where it helps to keep animals relatively clean.

Cattle wash down and drainage

A pressurised water washdown is the most effective for cleaning animals that are ready for dispatch to the abattoir and for cleaning the building floor.

Water pressure and volume need to be balanced. High pressure, low volume water will splatter solids, but a low pressure, high volume system may not move the solids. Hose length will determine how many hoses are required and the location of the reel or connection.



Rubber belt soft flooring with 40 mm holes punched in the rubber for non-slip effect.



Suspended woven-mesh floor. The mesh is securely attached to the top of aluminium stirrups.

Hose reels prevent safety hazards caused from hoses lying on the ground. However, as fire hose reel assemblies may not deliver enough volume of water, they would need to be designed to suit specific feedlot purposes.

Washdown water has to be directed to the feedlot drainage system (see *Section 10 – Pen and drainage systems*) and, as it contains manure, it must be directed to a sediment trap (see *Section 11 – Sedimentation removal systems*). Open drains are preferred, as they are more easily maintained than underground pipes. Any underground pipe must have a good slope and preferably no junctions or bends to restrict flow.

Staff amenities

Extra amenities may be needed in those feedlots where the processing facility is located some distance from the main office, or where cattle handling staff are more numerous. In larger facilities, the amenities can be part of - or inside - the processing area building.

The key design considerations include

- Are toilets or change rooms required?
- What will be required (e.g. hand washing and showers)?
- Will some separate personal hygiene facilities be needed for male and female staff?
- Will the facility be used as a meal room and, if so, will air conditioning and a mini-kitchen be required?
- Will it be used as an office to house computers and require a data/network connection and phone?
- Will it be used to house veterinary supplies, including medicines and vaccines?

Quick tips

- Plan a building for, or structure over, the processing facility during the design phase of the project.
- The crush area and race need the most protection from weather.
- The building or structure needs to be functional, but not elaborate or overly expensive.
- The type of building required will depend on the number of animals to be processed, operations to be performed, when they are to be performed, space restrictions, personal preferences and budget.
- Water off the roof should be directed away from the building and into the pen drainage system.
- Water off the roof will be contaminated with manure dust and unsuitable for human consumption.
- Consider shadows cast by buildings or bright light intrusions during layout and design to prevent cattle baulking.
- The most appropriate dimensions, orientation and configuration of patterns to create a slip-resistant concrete floor are not 'fixed in concrete'.
- Direct washdown water from the facility to the feedlot drainage system via a sediment trap.

Further reading

- Albright, J.L. 1995. Flooring in Dairy Cattle Facilities. Proceeding from the Animal Behavior and the Design of Livestock and Poultry Systems International Conference. NRAES-84. Northeast Regional Agricultural Engineering Service. Cornell University, Ithaca, New York.
- Bray, D.R. 1998. Cow Comfort at the Feeding Area. Proceedings from the Dairy Feeding Systems Management, Components, and Nutrients Conference. NRAES 116. Natural Resource, Agriculture, and Engineering Service. Cornell University, Ithaca, New York.
- Dumelow, J. and R. Albutt. 1988. Developing Improved Designs of Skid-Resistant Floors for Dairy Cattle Buildings. Livestock Environment III. Proceedings of the Third International Livestock Environment Symposium. American Society of Agricultural Engineers.
- Dumelow, J. 1993. Simulating the Cattle Foot/Floor Interaction to Develop Improved Skid Resistant Floors. Livestock Environment IV. Proceedings of the Fourth International Livestock Environment Symposium. American Society of Agricultural Engineers.
- Grandin, T., and M. Deesing. 2008. Humane Livestock Handling. Storey Publishing, North Adams, MA.
- Kirchner, M. and J. Boxberger. 1987. Loading of the Claws and the Consequences for the Design of Slatted Floor. In: Cattle Housing Systems, Lameness and Behavior. Proceedings of Comm of Europe Communities, Brussels. Eds HK Wierenga & DJ Peterse. Martinus Nijhoff Publishers, Dordrecht.
- McDaniel, B.T., M.V. Hahn, and J.C. Wilk. 1982. Floor Surfaces and Effect Upon Feet and Leg Soundness. Proceedings from the Symposium on Management of Food Producing Animals II. Purdue University.
- Welchert, W.T. and DV. Armstrong. 1992. Anti-Slip Concrete Floor Specifications. Proceedings from the National Milking Center Design Conference. NRAES-66. Northeast Regional Agricultural Engineering Service. Cornell University, Ithaca, New York.

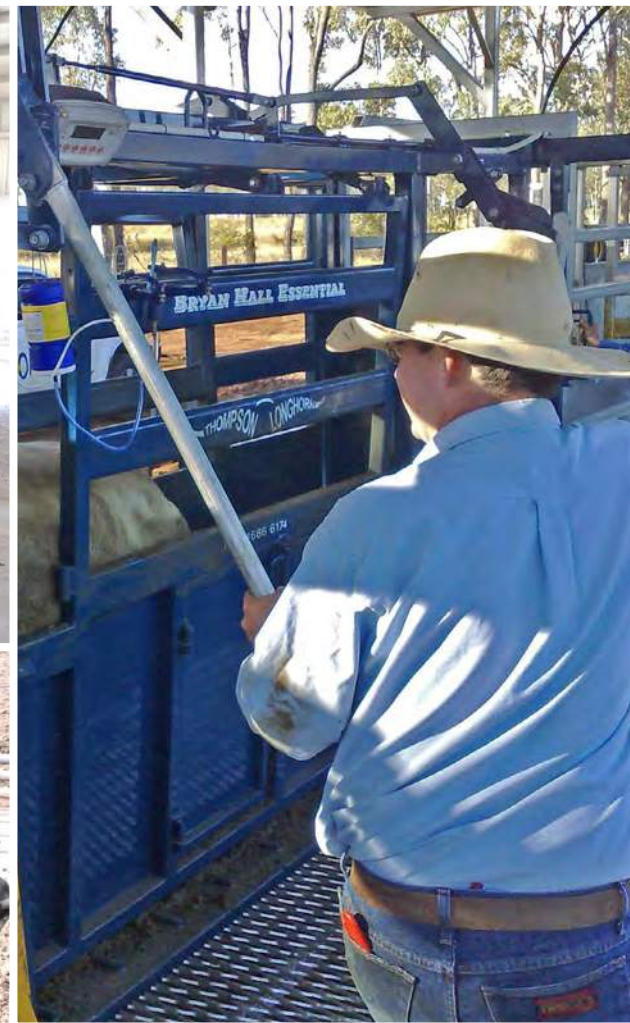

FEEDLOT DESIGN AND CONSTRUCTION

25. Cattle crushes

AUTHORS: Rod Davis and Scott Janke

Introduction

Cattle have to be constrained during routine operations, such as recording, vaccinating, ear tagging, weighing and animal health tasks (and possibly veterinary procedures). A cattle crush holds the animal immobilised to minimise the risk of injury to both the animal and the handler.

An effective livestock handling system requires a suitable choice from a wide range of commercially available cattle crushes.

The operations to be performed will determine what features the crush will need, including veterinary sections, baulk gates, a squeeze mechanism or split side gates. Crushes to be used in the processing facility usually have more functions than those needed for hospital facilities.

Functionality and ease of use by handlers should be prime considerations. Operator safety may be improved if the squeeze section of the crush is operated hydraulically or pneumatically rather than manually. All crushes should be made according to good manufacturing standards using quality materials.

Cattle crushes can be equipped with ancillary equipment, such as chin bars and automated drafting systems. Electronic scales and a National Livestock Identification System (NLIS) identification reader are now standard in most feedlot cattle crushes.

Design objectives

The cattle crush should be designed, constructed and maintained to ensure that

- An animal is adequately restrained.
- The risk of injury to animal and handler is minimised while operations are performed.
- The equipment has the proven ability to effectively restrain the type of cattle being handled.
- The design allows for a safe and easy release should an animal fall during the operation.
- Access is provided on both sides of the animal.
- The floor surface is non-slip.
- Gates and head bail operate effectively to capture and secure stock and do not release when kicked or struck.
- It has easy, quick and quiet operation.
- It has solid and secure anchorage points.
- It is versatile and suitable for all jobs to be performed - this will determine where access to the animal is necessary (e.g. head, sides and rear).
- It is safe to use for handler and cattle with no sharp edges, protruding catches, bolts or wire.
- It is durable.
- It provides value for money.
- It is serviceable and easily maintained with greasing points.
- It is not cluttered with features irrelevant to the intended use.

Mandatory requirements

Compliance with

- Australian Animal Standards and Guidelines for Cattle (DAFF, 2013)
- National Guidelines for Beef Cattle Feedlots in Australia (MLA, 2012a)
- National Beef Cattle Feedlot Environmental Code of Practice (MLA, 2012b)
- NFAS standards (AUS-MEAT, 2014).

Design choices

Typically the cattle crush is the most important part of a processing facility and everything else is planned around it. It may be part of a race, a separate facility at the end of a race, free standing under a roof or located in a suitable building.

The processes to be performed, handling requirements and personal preference will define the configuration and control of the various elements of the crush.

The features to be assessed when selecting a crush include

- Location
- Functionality
- Design
- Construction
- Controls
- Electronics
- Operator safety
- Maintenance
- Noise.

Figure 1 provides a conceptual representation of the relationships and structure between the various elements of a crush.



Figure 1. Conceptual representation of crush design factors.



Hydraulically-operated crush with multiple features.



Manually-operated crush.

Location

The following criteria need to be considered when setting up the crush

- Side of operation – nearside or offside – as most people work with cattle from the left side, or the nearside, of the animal.
- Where roof is constructed over a crush, overhead lighting will need to be installed.
- There should be no sharply contrasting shadows or bright patches that may baulk cattle.
- Cattle should be able to see well ahead.
- There should be no distractions to forward movement.
- The crush exit is designed to allow processed animals to be separated from the work area.
- Solid and secure anchorage points (preferably set in concrete).
- Access to pressurised water supply.
- With a roofed area, the floor surface needs to be able to be thoroughly cleaned and disinfected as required.

Features

There are many crushes commercially available that have varying configurations. A basic crush consists of: a head restraint (head bail), side squeeze panels, associated animal control equipment (e.g. chin bar and squeeze), veterinarian section and access gates. Although some crushes have a reverse-out configuration, a walk-through design is essential when handling large numbers of cattle.

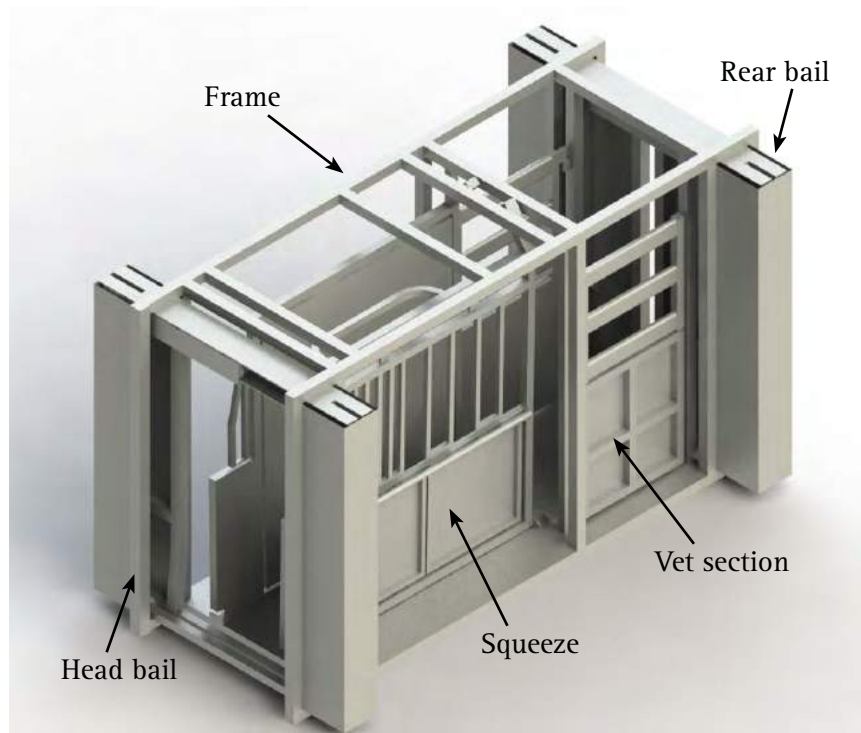

Figure 2. Features of a crush

Head bail

The front end of a crush has a head bail (or neck yoke or head gate) to initially catch and restrain the animal. The head bail is operated manually using a side lever, or mechanised using a remote control. It is often adjustable to accommodate animals of different sizes. It may incorporate a chin or neck bar to hold the animal's head up and still.

Regardless of the configuration, the head bail should

- Be safe and easy to operate – with no holes in which hands or fingers could be caught.
- Provide adequate head control without causing injury to cattle.
- Have incremental adjustment for different classes of stock.
- Have a positive locking system that can be operated with one hand only.
- Be quiet when being operated.

Head bails may have a V-shaped or parallel opening, with or without additional head restraint (e.g. neck extenders and/or chin lifters). The advantages and disadvantages of each type are outlined below.

V-opening

The V-opening head bail consists of two bi-parting halves that have pivots at the bottom. After release, the animal walks out through the head bail. Halve bars that make contact with the animal's neck may be curved or straight. The V design has fewer moving parts and requires low maintenance.

The curved bar is one of the most popular general purpose designs, with the curved bars forming a diamond shape when closed. This provides better head control because it prevents the animal from sliding its head up and down – and so reduces the need for a neck extender.

The straight bar provides poorer head control because the animal can slide its head up and down. But choking is almost impossible because the straight bars cannot press on the throat.

A curved bar V-opening is recommended for general cattle handling in feedlots. A straight bar V-opening is recommended where an animal must remain in the head gate for a long period.



V-opening crush – looking back into lead-up race.

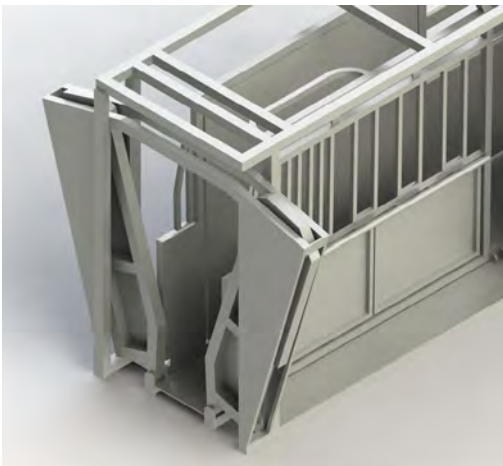

Figure 3. Schematic example of straight bar V-opening crush



Parallel-opening crush.

Parallel opening

This consists of two bi-parting halves that open and close similarly to a pair of sliding doors. Halve bars may be straight or curved.

The parallel opening head bail allows large animals to walk through more easily without knocking their hip bones. But the sliding mechanism is more complicated.

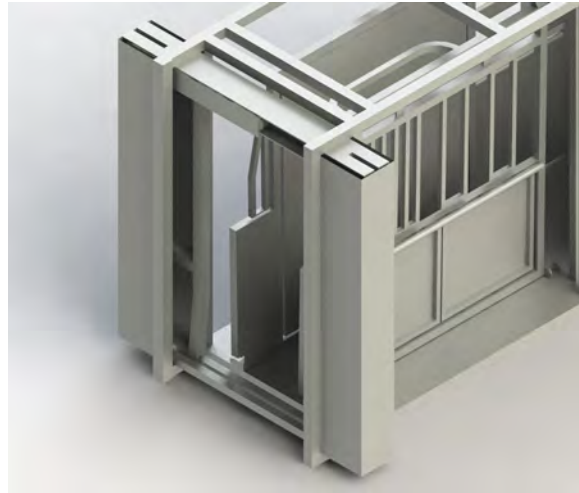

Figure 4. Schematic example of straight bar parallel opening crush



Neck extensions on head bail doors.

Neck extenders

A neck extender is an additional neck restraint that can be attached to the head bail to reduce head movement. All neck extenders put pressure under the throat, which may hinder some tasks. Caution is required during operation, as the animal may fall in the crush.

Baulk gate

At the front of the head bail, a crush may have a baulk gate that swings across to inhibit an animal's forward movement after it enters the crush and to prevent it from passing through while the head bail is being closed.

The key design requirements include that the baulk gate is simple and easy to latch, folds back out of the way and that rail spacings are adequate.



Manual chin lifter in operation.

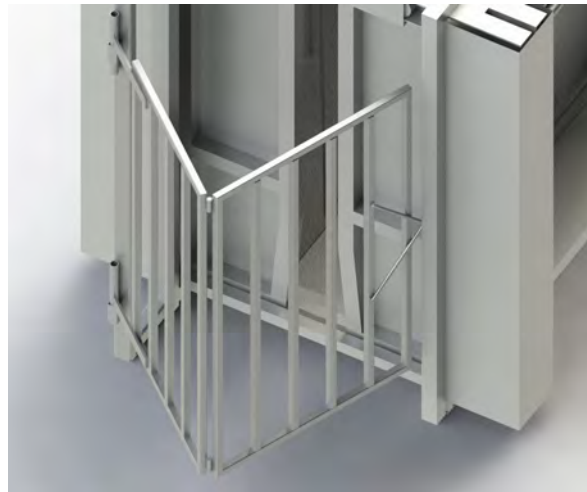

Figure 5. Example of a baulk gate

Head restraint

Head restraints are additional to neck extenders and are designed to reduce head movements for operations such as tagging ears and implanting Hormonal Growth Promotants (HGP). Common types are chin lifters or neck bars. A chin lifter is a cup, or bar, that raises the head of the animal to a suitable, safe position. A neck bar has two parallel bars, one above and one below the head, to restrict all head movement.

Squeeze

Most cattle will settle better if movement is restricted. A side squeeze immobilises the animal for safer animal control and operator safety.

Squeezes range from a side gate held against the animal with a simple drop-down rod to powered, adjustable single-sided and double-sided parallel or V squeezes.

In a single-side squeeze, the width of the crush is altered by moving one side panel of the crush—manually, hydraulically or pneumatically. This may push the animal off balance and the operator could be injured if the ratchet system intrudes into his or her space.

Parallel and V squeezes provide greater animal holding power.

The best designs are V squeeze crushes that have two movable side panels hinged at the bottom and pulled together by a lever system at the top, with both sides moving in evenly. The animal remains standing in a balanced position supported by the V shape. Correct adjustment of the space between the squeeze sides at the floor can reduce overt pressure on the lungs of cattle being restrained.

The squeeze mechanism should be simple to operate.

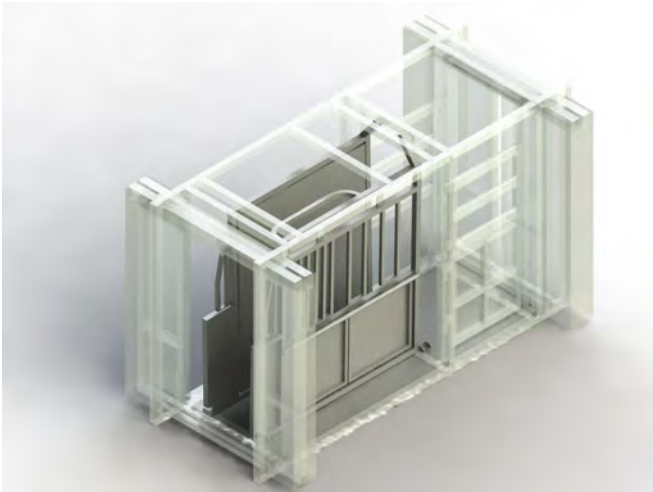

Figure 6. Schematic example of the squeeze mechanism of a crush

Veterinary section

A veterinary section is an access panel that is required for any operations at the rear end, or side, of an animal. It provides protection for operators against being kicked and should be able to be operated by either a left or right-handed person.



Pneumatic head restraint and pneumatic chin lifter. Yellow panels highlight nip/crush points and moving parts to handlers.



Full-length squeeze where animal can stand freely without being head bailed, but this does not provide safe access to the head.



Veterinary gates allow access for operations at the side and rear of the animal.

Rear bail

A rear bail can be the same style as the head bail, particularly if it is powered in the same way as a split sliding gate or solid slide in manual operations. The rear bail can be used to quickly trap an animal in the crush before it is caught with the head bail, while stopping the next animal in the race from entering the crush at the same time.

Design

Types

Most feedlots with high throughput of cattle use hydraulics or pneumatics, instead of manual power, to operate the cattle crush in the main cattle processing facility. Other facilities that handle fewer cattle, such as hospitals, may install manual cattle crushes.

The pneumatic system has better pressure control, less maintenance, and better safety and economy. The hydraulic system provides quiet, solid and more accurate control.

A correctly adjusted hydraulic or pneumatic crush is usually safer for animals and operators. Most have a factory adjusted pressure relief valve that prevents excessive squeeze pressure being applied to the animal. Operators are less likely to tire and make errors that can result in an accident.

With crushes powered by hydraulics or pneumatics, the pump, motor or compressor should be located away from the animal handling area and the plumbing designed to minimise noise.

Width

A crush is typically between 680mm and 750mm wide internally, with the narrower crush used to handle smaller animals. Animals should not be able to turn back.

The shape of a V squeeze helps to support the animal. The inside width at the base of the squeeze is 280–400mm to allow for an animal slipping, or losing its footing, while in the crush.

Height

The internal height is usually measured in the head bail, as this is typically the lowest point in the crush.

A height of 1600mm is acceptable for most breeds of cattle, but larger-framed or fractious cattle may need a height of 1800mm.

Length

The length is commonly referred to as the squeeze length, which is the distance between head bail and rear bail for crushes without a veterinary section, or the distance between the head bail and kick gate in crushes with a veterinary section.

Crush length is normally 2000–2400mm, with the shorter length acceptable if all animals are caught in the head bail.

Construction

Construction materials not only need strength and durability, but also properties that minimise injury, bruising and stress to animals.



Split-side gate for release of an animal if it goes down.

Most lower cost, quality crushes are built using standard heavy steel pipe that is welded together. There are higher quality crushes manufactured using doubly-symmetric oval tubing for superior bending strength and rigidity and to minimise bruising of cattle.

Cattle crush construction should also ensure

- Quiet operation by limiting undue noise (such as from a metal floor).
- Minimal dirt build up (thus reducing corrosion).
- Ease of cleaning.
- Moving parts are physically easy to operate and guarded for operator safety.
- Ease of maintenance with accessible greasing points.
- Railing that is strong, yet quiet when knocked by cattle.
- Rust prevention measures, such as galvanising, undercoating and anti-corrosive paint.
- An ability to add additional items (e.g. load cells, chin lifter, automated vaccination or drenching mechanisms).

Gates and latches

Gates and latches are an integral component of all crushes. Gates provide access for various animal operations to be carried out. Gates of various configurations can be provided at almost any location around the crush. These are generally named after the operation, or access points, such as side gates, split gates, veterinary gates, vaccination gates, branding gates or sliding gates.

Side gates and split side gates provide access to the sides or underside of the animal and are easily released if an animal falls in the crush.

Vaccination gates (with auto catch) are located at the head bail end of the crush and provide access to the neck for vaccinations. Veterinary gates at the opposite end of the crush to the head bail provide access for veterinary procedures.

Latches ensure that gates and head bails do not release when kicked or struck. These should operate easily, be positive catching and lock securely without undue time or effort. Worn latches should be easy to replace.

Manually operated head bails and squeezes typically have a ratchet latch that locks into a definite notch as the head gate or squeeze is closed. It may be noisy, but is safer because it is less likely to be released accidentally or under pressure.

Hydraulically operated head bails are locked by the hand valves, but pneumatically operated head bails need a secondary ratchet or friction brake because air is compressible.

Controls

Controls differ between manually operated and power assisted crushes and are located on the operating side of the crush (on the near-side or off-side).

Manually operated crushes have a handle at the head bail and one for the squeeze - mounted near the rear of the squeeze. Some crushes also have a secondary handle for the head bail at the rear of the squeeze.



Side access gates for scanning and veterinary procedures.



Grease nipples on hinges for easy movement.



Hydraulic controls for a crush.

Handles should be able to be disengaged to reduce the risk of operator injury and provide better access around the crush.

Power assisted crushes may have either a control arm mounted to the side of the crush or suspension frame, or a control table. Control arms are typically able to pivot, allowing the operator to change location to get the best view of the operations. A control table can also be used to manage the crush from a distance and is recommended when load cells are mounted under the crush. Moving a control arm could interfere with the animal's weight.

Electronics

NLIS readers

The NLIS has been developed to enable lifetime identification of all Australian cattle. This enhances traceability in the event of a disease outbreak, food safety or residue contamination issue.

NLIS uses radio frequency identification devices (RFIDs) and a national database to record individual animal movements. NLIS devices for cattle can be a visual ear tag with an RFID embedded, or combined with a visual ear tag

Feedlots need equipment to electronically scan and read the NLIS tag and transfer the movement records to the NLIS database. Electronic scanning equipment is commercially available in several forms and with the ability to perform a range of functions. Electronic scanning equipment may be either hand-held or race readers.

Electronic scanning readers may have different functions across four basic areas of

- **Display** – display the RFID number as it reads.
- **Memory** – retain the RFID number or simply read and transmit the number.
- **Additional fields** – capture the RFID number and information such as feedlot ID number, pen number or lot number.
- **Transmission** – communicate using either a serial RS232 cable or a wireless connection.

Race reader

A race reader mounted on the side of a crush or race, either permanently or as required, can be used to automatically read the RFID of individual animals as they pass. Race readers can read across a race, cattle weighbridge and loading or unloading bay. With a larger antenna, race readers have a typical read distance from 20cm and up to 1.2m. A race reader is also commonly referred to as a panel reader, using a panel antenna and fixed reader.

Hand-held reader

A hand-held reader is operated manually and usually consists of a wand that is activated by pressing a button when it is positioned near the identification device to be read. Hand-held readers typically have memory and download capacity.

These are commonly referred to as portable wand readers, or stick readers. A hand-held reader will typically have a read distance of up to 600mm, with a minimum of 50mm for reading ear tags.



Operating console for a pneumatically-operated crush.

Read distances provided by manufacturers for different types of readers should be confirmed and a performance agreement made with the manufacturer providing the expected performance once it has been installed.

The full benefits of the electronic scanning equipment can be realised with an advanced system that can also measure performance and health status.

Weigh scales

Accurate assessment of cattle performance and treatments rely on accurate weighing.

Scales are often incorporated into the cattle crush. Using the squeeze mechanism to reduce animal movement will speed up weighing, while allowing animal husbandry to be conducted at the same time. But a separate weigh box may be needed if more accurate weighing is required (see *Section 23 – Cattle processing*).

A weigh system comprises weigh bars (or cells), cables, plugs and displays. The weigh platform sits on the weight bars and its electrical resistance changes in proportion to the weight applied.

Cables carry the current from the power source (usually the display) and the current signal back to the display. As most problems with scales arise from damaged or faulty connections, shielded cables should be protected from physical damage by livestock, birds and rodents. Connectors should be marine or military grade to prevent water entering the cables. Screw-type caps and 'O' rings will reduce the chance of moisture entering the display.

Displays with more features are more expensive, but can carry out a wider range of tasks. Many systems have data logging capability.

The type of weighing system used depends largely on the level of information required. The factors to consider when implementing a weighing system include

- Weighing capacity – appropriate for the range of cattle to be weighed (taking into account the weight of the cattle crush or weigh box).
- Shock absorbing capacity of the weigh bars – rubber mounts protect the weigh bars and maintain weighing accuracy.
- Waterproof and dust proof displays.
- Power supply options – more than one (e.g. 240V and 12V) is an advantage.
- Display contrast and size of numbers – variable contrast depending on lighting and large numbers for ease of viewing.
- Cable protection and quality of cables and plugs.
- System integration with cattle management software (e.g. datalogging, data format and software).
- Ease of setup, use and troubleshooting.
- Whether the cells will be located under the crush, or the crush will be suspended.

The potential installation of weigh scales should be included in the design of a cattle handling system so that these can easily be added later if required.



All cabling for control and electronics should be protected from damage.



Crush mounted on load cells for weighing.



Wear pads reduce wear, and rubber stoppers reduce noise, shock and fatigue.



NLIS reader on race.

Operator safety

Cattle crushes should be designed to reduce injury risk to cattle and handlers. In terms of handler safety, the crush should have

- No sharp edges, protruding catches, bolts or wire.
- Gates, head bail and latches that are free of nip or crush points or have shields fitted.
- Work areas free of protruding obstacles and obstructions.
- Latches that are positive catching.
- Flooring that is non-slip.
- The unit secured to the ground.
- Adequate head clearance for operators.
- Adequate escape routes.
- Protection to minimise the risk of operators being kicked.
- Standard operating procedures.
- Adequate lighting.
- Adequate shade.

Maintenance

A crush will typically have the most moving parts of all of the animal handling equipment used in the yards. Routine checks and maintenance must be carried out to prevent down time and potential injury to operators. The following factors should be considered

- Are all greasing points easily accessible?
- Can replacement parts be easily purchased?
- Are there operator manuals?

Quick tips

- The type and frequency of operations to be performed will dictate the configuration and features of the crush.
- There are numerous designs and configurations of crushes available. Functionality, cost, ease of use and construction quality are important selection criteria.
- The cattle crush must be able to restrain cattle and minimise injury to cattle and handlers.
- A walk-through design is essential when handling large numbers of cattle.
- Ensure latches operate easily, are positive catching and lock securely.
- Feedlots require electronic equipment to scan and record NLIS data and animal performance data.
- Confirm read distances provided by manufacturers for a range of NLIS readers and instigate a performance agreement with the manufacturer once this equipment has been installed.
- Always plan for a weigh system when designing and installing the crush.
- Scales are often incorporated into crushes. Weighing will be faster if the animal is restrained by squeeze sides to reduce movement.

Further reading

AUS-MEAT, 2014, NFAS Rules & Standards (April 2014), AUS-MEAT Limited, Brisbane, Qld.

Cattle Crush Company – www.cattlecrushco.com.au

DAFF, 2013, Australian Animal Standards and Guidelines for Cattle, Department of Agriculture, Forestry and Fisheries, Australian Government.

MLA, 2012a, National Guidelines for Beef Cattle Feedlots in Australia. Meat & Livestock Australia, Sydney, NSW.

MLA, 2012b National Beef Cattle Feedlot Environmental Code of Practice. Meat & Livestock Australia, Sydney, NSW.

RPM Rural Products www.rpmrural.com

National Stockyard Systems Pty Ltd – www.nationalstockyards.com.au

Thompson Longhorn – www.thompsonlonghorn.com.au

NSW Government, 2010, Stock Diseases Act 1924 No 34.

WA Government, 1968, Stock Diseases (Regulations) Act 1968.

Queensland Government, 2013, Stock Act 1915.

South Australian Government, 1991, Stock Act 1990.



FEEDLOT DESIGN AND CONSTRUCTION

26. Office and amenities

AUTHORS: Orla Keane and Peter Watts

Introduction

A feedlot office is a dedicated structure used primarily for conducting management and administrative functions at the feedlot. It facilitates administration and clerical activities, visitor induction, meetings, employee offices and storage for company records (e.g. financial, animal performance and inventory).

At a large feedlot there may be a main office and additional offices at the feedmill and/or cattle handling facilities. All offices must meet minimum workplace health and safety standards.

Employee amenities, which may form part of the office facility, can include a dining area, drinking water, toilet/s, hand washing facilities, first aid station and/or car parking.

Design objectives

The design objectives for office and employee amenities are to provide

- Facilities for administrative and clerical activities.
- Meeting room for employees and visitors.
- Secure storage for keeping records.
- A safe workplace for feedlot employees.
- Appropriate amenities/facilities for employees.
- Suitable first aid facilities in the event of an accident.

Mandatory requirements

A person operating a feedlot has the primary duty under the Work Health and Safety Act (2011) (the WHS Act) to ensure, so far as is reasonably practicable, that workers and other persons are not exposed to health and safety risks arising from the business.

The Work Health and Safety Regulations (2011) (the WHS Regulations) put more specific obligations on a person operating a feedlot in relation to the work environment.

The Code of Practice: Managing the Work Environment and Facilities (2011) is an approved code of practice under Section 274 of the WHS Act. It is a practical guide to achieving the standards of health, safety and welfare required under the WHS Act and the WHS Regulations.

Regulation 40 of the WHS Regulations (2011) states: A person conducting a business or undertaking must ensure, so far as is reasonably practicable, that

- The layout of the workplace allows, and is maintained to allow, persons to enter and exit the workplace and move within it safely, both under normal working conditions and in an emergency.
- Work areas have space for work to be carried out safely.
- Floors and other surfaces are designed, installed and maintained to allow work to be carried out safely.
- Lighting enables each worker to carry out work safely, persons to move around safely and safe evacuation in an emergency.
- Ventilation enables workers to carry out their work without risk to their health and safety.

- Workers exposed to extremes of heat or cold are able to carry out work without risk to their health and safety.
- Work in relation to, or near, essential services (such as gas, electricity, water, sewerage and telecommunications) do not affect the health and safety of persons at the workplace.

The National Construction Code of Australia details the guidelines required for new buildings.

The Code of Practice: First Aid in the Workplace publication provides practical guidance about requirements for first aid facilities.

Design choices

Office

The feedlot office and car park should be located on the entrance road to the feedlot, before the feeding pens and other operating facilities (see *Section 2 – Feedlot site layout*). The entrance road should provide for all weather conditions and be designed for two way vehicle movements. Situating the car park before the office reduces traffic congestion and improves safety and biosecurity in the feedlot complex. Prominent signage should advise all visitors to park their cars and report to the office. The weighbridge for livestock and feed commodity deliveries is usually located adjacent to the main feedlot office.

The size and layout of the office, and the facilities needed, depends on the feedlot capacity. Larger feedlots generally have a designated feedlot office, typically with

- A reception area; a counter for visitors to complete a biosecurity check, safety induction and other forms; a waiting area with seating; and a private office for the manager and/or other senior employees.
- A meeting room.
- A glass window or door that provides employees with a clear view of vehicles entering the feedlot and trucks arriving on the weighbridge.
- Windows that provide a clear view of outside activities.
- Work stations for administration employees.
- Computers and associated infrastructure; feedlot management and business management software; high speed internet; a telephone system; ergonomic office furniture; and records storage.
- A separate meal room.
- Male and female toilets.
- Shower and/or a change room.
- Lockers (or similar) for storage of employee personal effects.
- A designated first aid treatment area or room.
- Air conditioning to provide a comfortable work environment and minimise dust accumulation.
- Parking for employees, visitors and trucks.
- Video or audio connection to security gates.
- A communication hub (e.g. UHF system for site) and connection to AWS and the feed management system.
- clearly displayed emergency contact numbers.



Relocatable pre-fabricated buildings provide a cost-effective solution for office and/or employee amenities.

A larger office may be needed if the feedlot size increases. The office should be situated in a location that allows for future expansion. The layout of the office, and the placement of furniture and fittings, should provide a functional, comfortable workspace.

At a small feedlot, a structure with a work station for the manager and/or administration employees, a dining area, toilet and first aid facilities may be adequate. This could be part of the feedlot manager's house, or another farm building - or it could be a small stand alone office. A second hand demountable building can provide a low cost, suitable space.

Dust

Dust from roads and pens can be a major problem around office buildings. Inside the office, dust can damage electronic equipment and provide a disagreeable work environment.

Offices should be air-conditioned and well sealed to prevent dust entering. Dust generated near the office should be minimised with sealed roads and/or landscaped lawns.

Employee amenities

All workplaces must provide ready access to hygiene and welfare facilities, such as toilets, hand washing amenities, first aid facilities, drinking water, eating areas and shelter for all people. A large feedlot may need to provide some of these facilities at multiple locations.

Clean, hygienic toilets must be accessible by all people, including those with disabilities. The number of toilets required depends on the total number of employees and visitors that will use the facility and on the type of building. In most workplaces, there must be one closet pan toilet for every 20 males and one urinal for every 25 males. For females, there must be one closet pan toilet for every 15 people. The Building Code of Australia provides the standard guidelines for the number of toilets required.

Generally, separate male and female toilets are required - although a unisex toilet may suffice if there are less than ten employees in total and less than two people of any one gender. If showers or change rooms are needed, there should be at least one cubicle provided for every ten people. Privacy should be assured. Usually separate facilities are provided for male and female employees.

Readily accessible hand washing facilities with hot and cold water, hand cleanser or soap and hand-drying facilities (e.g. paper towels) must be provided in toilets. These may also be recommended for other areas, such as the workshop, chemical storage area, mill and livestock handling areas where people may be exposed to grease, chemicals, infectious substances or other contaminants. Similarly, an open shower facility may be provided outside a chemical store (see *Section 39 - Agricultural and veterinary chemical storage*).

As working in a feedlot poses some inherent safety risks, a well equipped first aid station is essential. A designated first aid room may be provided at a large feedlot, while a readily accessible, well stocked first aid kit may suffice at a smaller feedlot. First aid kits should also be located at convenient points around the feedlot complex for accessibility and in areas where there is a higher risk of injury or illness occurring (e.g. cattle induction area).



Modular relocatable building (a 'donga') used for a First Aid post.

If a designated first aid room is provided, it should

- Be available when workers are at work.
- Be clearly identified as the first aid room and used only for that purpose.
- Be close to vehicle access (a room in the main office is ideal).
- Have entrances and corridors wide enough to fit a stretcher.
- Be close to toilets and telephones.
- Offer a comfortable environment (ventilation, heating, cooling and lighting).
- Provide space for movement around furniture and equipment.
- Have an examination couch, or bed, with a waterproof surface and disposal sheets.
- Have an examination lamp with magnifier.
- Have clean bench tops/floors/surfaces.
- Have a hand basin, hot and cold running water, soap and paper towels or hand cleanser.
- Have a cupboard for storage.
- Provide a first aid kit appropriate for the workplace.
- Have designated waste containers for the safe disposal of materials contaminated by blood or body substances and sharp instruments and a bowl or bucket (minimum two litres capacity).
- Have electric power points.
- Have a sign on the door showing the name of the person in charge, the person on duty, the names and locations of the nearest first aid personnel and contact numbers in case of emergency and have a chair and a table/desk.
- Provide a telephone and/or emergency call system.
- Clearly identify the names and contact details of first aiders and emergency organisations.

The contents of a first aid kit should consider the risks posed by working at a feedlot. At a minimum, basic equipment should be sufficient for administering first aid for injuries such as

- Cuts, scratches, punctures, grazes and splinters
- Muscular sprains and strains
- Minor burns
- Bleeding wounds
- Broken bones
- Eye injuries
- Insect and snake bites
- Shock
- Heat stroke
- Concussion.

Employees must be able to readily access clean drinking water at all times. This should be separate from the toilets or washing facilities to minimise the risk of water contamination. As well as in the office, a drinking water supply should be provided in areas where hot or strenuous work is undertaken (e.g. cattle induction area and feedmill).



Permanent office and employee amenities building with adjacent weighbridge.

An eating area should be provided for all employees. Often there is a meal room set up in the office at large feedlots, although additional sheltered meal areas may also be provided. At a small feedlot, the eating area could just include facilities for making tea and coffee, storing food and washing. At all feedlots, the eating area should be supplied with

- Seating suitable for adults.
- A sink with hot and cold water, washing utensils and detergent.
- An appliance for boiling water.
- Clean storage, including a refrigerator for storing perishable food.
- A microwave oven for re-heating or cooking food.
- Vermin-proof rubbish bins, which should be emptied at least daily.

Access to shelter, that provides protection from the sun and inclement weather conditions, should be provided for all people.

Landscaping

A well maintained landscape area around the exterior of an office enhances the visual amenity and ambience, reduces dust and gives new visitors a good first impression of the operation. The landscaped area can also serve as a fire break and an emergency assembly point.

Lighting

The feedlot office should be equipped with adequate external and internal lighting to ensure general activities can be completed safely. Good lighting is also beneficial for security purposes.

Wherever possible, and provided safety is not compromised, all site lighting should be directed downward and incorporate glare shields. The location of external lighting and its potential light spill is an important ecological and social consideration in relation to safety, accessibility and aesthetics.

Suitable internal and external lighting may be installed according to relevant Australian Standards

- AS/NZS 1158.3.1:2005: Lighting for roads and public spaces - Pedestrian area (Category P) lighting - Performance and design requirements, Strathfield NSW and Standards New Zealand, Wellington.
- AS/NZS 3000:2007: Electrical Installations (known as the known as the Australian/New Zealand Wiring Rules).
- AS/NZS 1158.6:2010: Lighting for roads and public spaces - Part 6: Luminaries.

Essential safety measures

The Building Code of Australia outlines the essential safety measures that apply to the various classes of buildings defined by the Building Code of Australia (for details see: www.abcb.gov.au). Essential safety measures are the fire, safety and health items installed or constructed in a building to ensure adequate levels of fire safety over the life of the building.

A feedlot may have multiple classes of buildings at the site. For example, Class 1a (single dwelling detached house), Class 1b (guest house/accommodation), Class 5 (office building), Class 10a (a non-habitable building or shed) and Class 10b (structure) may all be present.

Essential fire safety measures for the suppression or fighting of fire include traditional building fire services and passive fire safety measures.

Traditional fire safety equipment includes

- Portable fire extinguishers
- Smoke alarms
- Fire hose reel system
- Fire hydrant system
- Automatic fire sprinkler system.

Passive fire safety measures for buildings include:

- Exit doors
- Fire doors
- Fire-rated structures
- Other building infrastructure such as paths of travel to exits.

Not all of these measures are required in all buildings. The requirements are stipulated in the Building Code of Australia, respective State Building Fire Safety Regulations and the relevant Australian Standards.

For example, the Building Code of Australia (E1.3) requires

- The installation of a fire hydrant system to serve a building having a total floor area greater than 500m².
- A fire hose reel system must be provided
 - (i) to serve the whole building where one or more internal fire hydrants are installed; or
 - (ii) where internal fire hydrants are not installed, to serve any fire compartment with a floor area greater than 500m².

For Class 1 buildings, the travel distance to an exit doorway must be not more than 6m.

Ensuring that a building has a floor area of less than 500m² negates the requirement for a fire hydrant and hose reel system. Nevertheless, portable fire extinguishers and smoke alarms are the minimum provision for any building.

Parking

Vehicle parking at the office should be divided into two areas. A signed carpark for visitors should be on the feedlot entry side, so that all visitors must proceed to the office before entering the feedlot complex. A carpark on the other side of the office is for vehicles moving around the feedlot complex.

These two carparks are often on either side of the weighbridge.

Quick tips

- Consider the location of the office during the overall concept layout stage of a new feedlot. An office at the entrance to a feedlot provides a control point for security and biosecurity purposes.
- The size, layout and construction of the office and employee amenities depends on the feedlot capacity.
- At a small feedlot, the office may be part of the manager's house or in a small demountable-type building.
- The size of the office may need to increase if the feedlot expands. The office should be situated at a location that allows for expansion as required.
- A larger feedlot will usually have a dedicated structure.
- Employee amenities need to be provided. Employees require access to toilets, hand washing amenities, first aid facilities, drinking water, eating areas and shelter. For practical reasons, it may be appropriate to provide some of these facilities at multiple locations.

Further reading

Local Authority Planning Scheme: for local requirements for building and staff provisions.

Australian Building Codes Board (ABCB), 2013, Volumes One and Two of the National Construction Code of Australia.

Safe Work Australia, 2011, Code of Practice: Managing the Work Environment and Facilities,

Safe Work Australia 2011, Code of Practice: First Aid in the Workplace, Safe Work Australia, Canberra.



FEEDLOT DESIGN AND CONSTRUCTION

27. Truck weighbridges

AUTHORS: Mairead Luttrell and Peter Watts

Introduction

Lot feeding is a high turnover, low margin business requiring precision management. Incoming and outgoing cattle, feeds, commodities and by-products (such as manure or compost) must be weighed accurately and efficiently. Most medium and large feedlots have at least one onsite weighbridge for these purposes.

Design objectives

A weighbridge at a feedlot must be designed and constructed to

- Comply with national trade weighbridge legislative requirements.
- Minimise travel times between the weighbridge and the loading/unloading areas.
- Protect feedlot security and biosecurity.
- Provide accurate and timely weighing of vehicles.
- Weigh vehicles of all sizes likely to enter or leave the feedlot.
- Provide good access for rapid entry, weighing and exit.
- Provide a safe working environment.
- Drain quickly and completely following heavy rainfall.
- Provide a safe location and infrastructure to enable feed commodity deliveries to be sampled for compliance with contracts.

Mandatory requirements

To ensure compliance with legislative requirements, weighbridge owners, operators and installers need to be familiar with the current weighbridge regulations from the National Measurement Institution (NMI). All trade weighbridges must comply with the National Measurement Act (1960) and the National Trade Measurement Regulations (2009) (Cth) (NTMR) - and the 1 July 2011 amendment.

If the weighbridge is used for trade, it must be pattern (design/type) approved and then tested by a verifier in accordance with the requirements in National Instrument Test Procedures (NITP) 6.1-6.4, which cover non-automatic weighing instruments. The weighbridge is 'used for trade' if it is 'used, or made available for others to use, to buy or sell goods to determine freight costs or other charges based on weight or to determine a tax'.

Design choices

Weighbridge location

The weighbridge should be situated beside the main feedlot office, or linked to it with communications and security cameras (see *Section 2 – Feedlot site layout*). It should preferably be close to the main entrance to the feedlot. It should be located away from the cattle pens to protect the biosecurity of cattle on feed. The site must allow for the easy and safe sampling of incoming commodities, so there should be clearance from other vehicle movements. Any vehicle using the weighbridge must be able to move on and off without the vehicle needing to turn on any part of the platform.



Weighbridge with good signage and a long sampling platform, allowing load to be inspected or sampled without repositioning the trailer.



A level, concrete, weighbridge approach as required by NMI regulations.

The weighbridge must provide the weighbridge operator with a clear view of each platform in its entirety and the measured weight at the same time, without the operator needing to move from their normal operating position.

Provision of accurate and reliable weighing of vehicles

To ensure accurate and reliable weighing of vehicles, the weighbridge needs to be properly situated, installed and maintained.

From the Weighbridge Operators Manual: A Guide for Operators who Conduct Public Weighings (National Measurement Institute 2013), the approach to the weighbridge must

- Have a hard, true and durable surface of concrete (or another approved material).
- Have a perimeter that is clearly marked from the surface by painted marks or other approved means.
- Be arranged so that drainage from the surface of the approach does not flow into the pit.
- Be in the same plane as the platform for a minimum distance of:
 - 3m if the length of the platform is less than 18m
 - 1m if the length of the platform is 19 metres or more.

The approach to a platform of a weighbridge that is at the entry or exit end of the entire weighbridge is in the same plane as the platform if

- For a weighbridge not used for end-to-end weighing, the entire surface of the approach is within +/- 2 degrees of level (horizontal) - measured from the end next to the platform.
- For a weighbridge used for end-to-end weighing, the approaches are within +/- 0.25 degrees of horizontal - measured from the end next to the weighbridge.
- For a multi-platform weighbridge, the dead space (if applicable) between the platforms of the weighbridge is level and in the same plane as each of the platforms.

Platform of the weighbridge

Each platform of a weighbridge must be composed of concrete and/or steel or another approved material.

For a multi-platform weighbridge

- The dead space between each platform must not exceed 2m.
- The operation of one platform should not affect the operation of any other platform.
- The upper surface of each platform should be on the same plane.
- A summing indicator must be installed.

A weighbridge with one or more pits must

- Cover each pit entrance.
- Provide free access to each part of the underwork.
- Be kept free from accumulated water, mud or debris either be free-draining or equipped with an automatic mechanical drainage.



The length of approach will depend on the overall length of the weighbridge. Note proximity to the site office.



A level concrete pad at the approach to a weighbridge keeps trailers level if prime-mover and trailers are weighed separately.



Load cell and weighbridge located above ground allows easy access for maintenance and re-calibration, and good drainage.



A multiple deck weighbridge allows the truck to be weighed in a single measurement.



This weighbridge can take systems up to B-Doubles (in length), but a road-train would need to be weighed one trailer at a time.



Boldly painted bollards placed at the entry and exit guide the truck driver and protect the weighbridge sides.

A weighbridge without a pit must provide

- At least 150mm clearance under the lowest live part of the platforms.
- A floor between the load cell supports that is made from concrete at least 75mm thick, that drains effectively and is kept free from accumulated water, mud or debris.
- Sufficient clearance from the external edges of the platform for servicing, maintenance and drainage.
- Stable load cell footings.

All electrical or electronic devices must be protected from the weather and electronic interference. The indicating device, and any summing device, is usually located in the feedlot office.

Truck dimensions

The weighbridge needs to be able to measure all trucks and other vehicles that are likely to require weighing. These may include

- Body truck (e.g. flat bed or tippers) with rigid chassis and bed of various lengths - up to about 12.5m.
- Semi-trailer – prime mover and load-carrying trailer with axles at the rear. The trailer is connected to the prime mover by means of a king pin. Typically this set up is about 19m in length.
- B-Train principle – B-Doubles, B-Triples or three trailers (B-Triples). A prime mover towing at least two trailers (B-Double). The trailers have a turn table at their rear, which another semi-trailer can connect to without the need for a convertor dolly. Typically this set up has a minimum length of 25m.
- Road Train – a road train is a combination other than B-Train, consisting of a prime mover towing at least 2 trailers. The second and subsequent trailers are usually a five or six axle dog trailer/s and connected to the first trailer with a convertor dolly. Road trains have a length of 36.5-53.5m.

Weighbridge access

Feedlot weighbridges should provide two-way access so that trucks can be weighed coming into and out of the feedlot. The access should allow trucks to straighten before they drive on to the weighing deck(s). *Section 13 – Access and internal roads* provides data about the turning circles needed for vehicles likely to be operating at feedlots. Installing markers, such as boldly painted, tall bollards, helps drivers to align vehicles with the weighbridge entrance. Good visibility on the approach and exit of the weighbridge should be provided.

Construction

The process of constructing a weighbridge includes construction of a foundation slab, followed by the construction of the weighing platform(s). Typically, the weighing platform(s) are constructed on the foundation slab and then jacked into position. The weighing platform(s) require sufficient lateral support to prevent platform deflection under heavy loading. Typically, weighbridges are designed by a suitability qualified and experienced structural engineer, or a company specialising in weighbridge installations.

Safety issues

The weighbridge and surrounding area must provide a safe working environment for drivers and other feedlot employees. Adequate directional and safety signage and clearance from other vehicle movements around the weighbridge should be provided. If sampling of feed commodities from an elevated deck is required, the design of the sampling deck (including handrails) must comply with relevant work, health and safety regulations and should be long enough to access all parts of the load.

Site drainage

The weighbridge site must drain rapidly after heavy rainfall and the deck and load cells must not be left inundated with standing water. Mud and other debris must not be allowed to accumulate around or under the weighbridge. If the site does not provide for free drainage, automatic mechanical drainage should be installed.



Weighbridge platform construction – concrete platform and reinforcing mesh needs to be well connected to the main lateral beams to prevent buckling.

Possible solutions

Weighbridge design alternatives are listed below. The choice for each site will depend on feedlot size, expected vehicle types, weighbridge location and other site specific factors.

Design choices include

- Deck type – steel only or steel and concrete decks.
- Deck length – single deck/multiple deck.
- Above ground/semi-pit or fully in ground installation.



Example of safety signage.

Concrete and steel deck

Advantages		Disadvantages	
Long-lasting surfaces	Provided the concrete is prepared correctly (vibrated and cured and steel reinforcement is positioned correctly), concrete is durable with hard-wearing surfaces.	Longer installation process	Both steel only and concrete and steel weighbridges require a concrete foundation. Concrete requires at least two weeks for curing to a suitable strength to allow the deck construction on the top. Concrete and steel decks then require a second curing period, whereas steel only weighbridges do not.
Heavy structure resists severe deck movements	The mass of the deck is significantly more than a steel only weighbridge and this mass resists movement as a vehicle enters or exits the weighbridge. This minimises rocking of the load cells.	More difficult to relocate	Concrete and steel weighbridge decks are heavy and typically larger than small, steel only modules. Relocation is therefore slower and more costly.
Less heat expansion	While the concrete and steel weighbridge uses steel main beams and cross pieces that will expand with heat, this movement is far less than with a steel only weighbridge. This minimises load cell off-centre loading.	Generally more expensive	With the trend towards minimal steel in steel only weighbridges, concrete and steel weighbridges are generally more expensive. However, if a steel-only deck is designed with sufficient steel, prices will be similar.
More confidence in the structural integrity	While concrete and steel weighbridges are not immune to structural failure, concrete and steel weighbridges have been shown to be longer-lasting.		

Steel-only deck			
Advantages		Disadvantages	
Long-lasting surfaces	Galvanised or well-painted steel is hard wearing. Even when the surface coating is damaged, steel forms a skin rust that prevents further corrosion. Weight for weight, steel is stronger than concrete.	Quantity of steel used must be questioned	Because the tops of steel decks are covered in a floor plate, it is difficult to ascertain just how much structural steel is used to fabricate the steel only deck. A general indication is the price of the deck. The lower the price, the less steel is used.
Fast and easier to install	Steel decks are usually fabricated in smaller modules and these modules are joined together to form the complete deck. The modules are easy to manipulate with a crane and easy to transport.	Lighter structure means more severe movement on the load cells	A steel deck is much lighter than a reinforced concrete deck and will move more vigorously as vehicles enter and exit the weighbridge. This causes more severe rocking movements and may compromise the longevity of other weighing components.
Easier to relocate	Light and small modules are easy to manipulate with a crane and easy to transport. But the concrete foundation is obsolete.	Steel expands more with heat	Both concrete/steel and steel only weighbridges expand with heat from the sun. Steel only weighbridges expand more, which means a larger buffer gap is required - allowing load cells a greater range of rocking movement. Load cells, especially end load cells, are also forced on to greater angles with the expansion, introducing greater off-centre loading.
Generally less expensive option	Steel only decks are generally less expensive, but this obviously depends on the amount of steel used. More steel makes a deck stronger, but requires more fabrication and labour to weld steel pieces together.		



Above-ground truck weighbridge with commodity sampling platform.

Deck lengths and installation options

Weighbridges can be single or multiple deck, and can be installed above ground (Figure 1), semi-pit (Figure 2) or fully in the ground (Figures 3 and 4).

1. Above ground Weighbridges

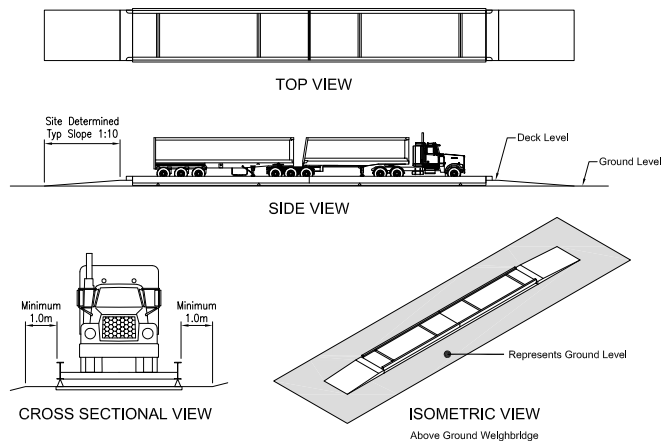

Figure 1. Above-ground weighbridge.

2. Semi-Pit Weighbridges

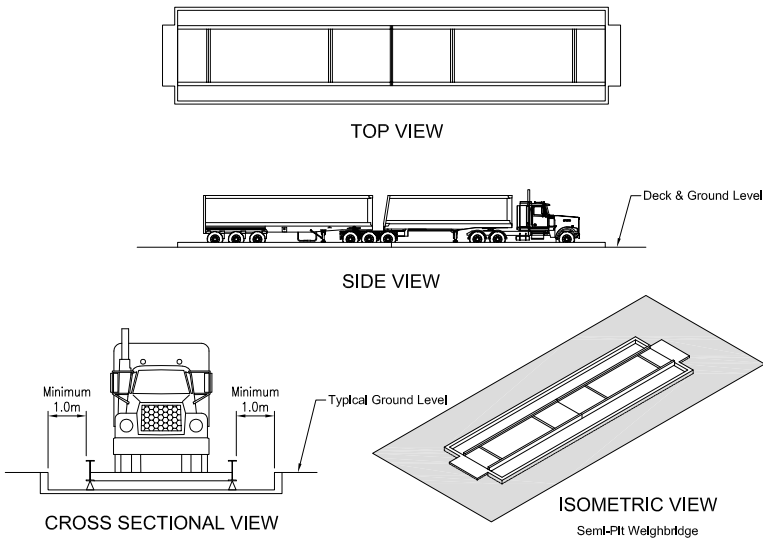

Figure 2. Semi-pit weighbridge.



Semi-pit weighbridge.

3. Fully In-Ground Weighbridges

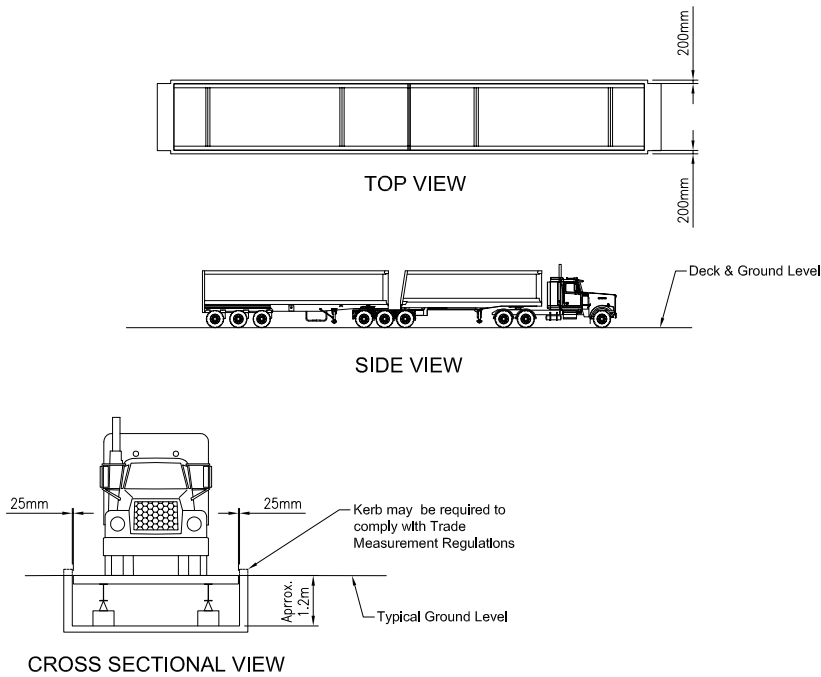

Figure 3. Fully in-ground weighbridge (top, side and cross-section view)



This weighbridge platform is too short for weighing prime mover and trailer together.

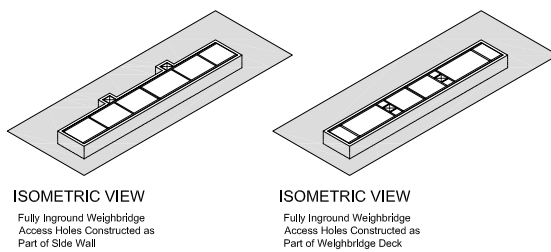

Figure 4. Access holes in fully in-ground weighbridges (isometric view)



Weighbridge for standing cattle.

Cattle weighbridges

While some feedlots weigh incoming cattle on the delivery truck, others provide a separate facility to weigh the cattle when they are unloaded and rested. The construction principles of a cattle weighbridge are similar to those of a vehicle weighbridge, except these are generally smaller and cattle tend to be weighed in batches to facilitate ease of handling.

To prevent injury to the cattle, the weighbridge will need a non-slip floor, which can be a removable structure for ease of cleaning. The need for regular washdowns of this facility will favour an above ground type of construction.

Quick tips

- Ensure weighbridge design and construction meet legislative requirements.
- Locate the weighbridge on the entrance road into the feedlot adjacent to the main office.
- Position the weighbridge so that the operator has a clear view of all platforms and the measured weigh without having to move.
- Provide straight access and distance markers to allow truck drivers to correctly position the vehicle on the platform.
- During design and construction, ensure there is sufficient lateral support provide to preventing ‘twisting’ of the platform—which can result in failure.
- For concrete and steel weighbridges, attention should be paid to how the concrete platform is connected to the steel beams. Poor connection can lead to failure.
- For grain sampling, provide a platform that is the same length as the platform deck. This will allow sampling/inspection to occur without the truck having to move forward or reverse backwards while on the weighbridge deck.
- Design the weighbridge site to drain freely after rainfall.
- Provide ready access to load cells and other areas needing regular maintenance or cleaning.

Further reading

National Measurement Institute (<http://www.measurement.gov.au/Pages/default.aspx>)

National Trade Measurement Regulations 2009 (<http://www.comlaw.gov.au/Details/F2009L03479>)

Verifying weighbridges (<http://www.measurement.gov.au/Services/Training/Pages/VerifyingWeighbridges.aspx>)



FEEDLOT DESIGN AND CONSTRUCTION

28. Feed preparation and storage

AUTHORS: Rod Davis and Ross Stafford

Introduction

Cattle in feedlots require a nutritionally and scientifically formulated grain based diet to meet production targets.

Metabolisable energy (ME), crude protein (CP) and fibre are the major components, with smaller quantities of minerals and vitamins added. The proportions of the commodities used in the formulated ration will depend on the desired level of cattle performance, the nutrient content of the individual feed commodity, the quantity of the feed commodity available, the current price of each commodity and the desired beef carcass conformation.

Ration preparation and delivery systems

For small feedlots

A pre-prepared or pre-mixed grain and supplement ration is delivered to the feedlot and fed out on site. The pre-mixed ration may be purchased from a commercial stockfeed manufacturer or from a feed mill on a neighbouring feedlot. Bulk storages are needed for the prepared rations, with storage for silage and/or hay to supplement the pre-prepared ration and a system for delivering the rations to the feed bunks. This option consists of a few simple structures and handling components.

For medium to large feedlots

Rations are prepared on site in a facility with associated commodity storage, handling and ration delivery infrastructure. The size and configuration of the system depends on the size of the feedlot and type of animals to be fed.

On site feed preparation and commodity storage requires an integrated system of components and processes. The basic components of an on site feed preparation facility include

- Grain storage and handling
- Grain processing
- Other commodity storage and management
- Silage storage and management
- Hay/straw storage and management
- Storage and handling of liquid ingredients and supplements
- Ration mixing and delivery systems.

The integrated components may include storage structures (such as silos, bunks and sheds), handling equipment (such as augers and conveyors) and grain processing, feed mixing and delivery operations.

Design objectives

The feed preparation and handling systems should be designed, constructed, operated and maintained to ensure

- The overall system meets the feedlot requirements for preparation and delivery of mixed rations.
- Good accessibility and traffic flow around the feedlot and within individual facilities.

- The design of each component meets the working needs of the facility and ensures efficient use of resources.
- Pre-prepared rations, grain and other commodities are unloaded, stored and handled to maintain product quality and minimise safety risks.
- Waste is minimised.
- Feed efficiency is maximised.
- Designated cattle performance is achieved.
- Suitable and convenient access for people and equipment (trucks and trailers) even in adverse weather.
- Allowance for unexpected interruptions in feed commodity deliveries due to industrial action or natural disasters.
- Potential expansion of feedlot capacity.

Mandatory requirements

The building elements, such as concrete footings, floor slabs and steel structures, shall achieve the structural provisions of the Building Code of Australia (BCA) and local building regulations and be designed in accordance with the relevant Australian standards.

Storage of industrial quantities of flammable and combustible liquids held in steel horizontal, rectangular and vertical tanks must comply with the methods described in the relevant Commonwealth, State and local authority codes, regulations and relevant Australian Standards (see *Section 38 – Fuel and gas storage*).

Compliance with relevant Commonwealth, State and local authority codes, regulations and relevant Australian standards for installation and operation of boilers. This includes boilers for the generation of steam, heating of water at a pressure above that of the atmosphere and boilers having any of the following sources of energy input – gas fuel, oil fuel, solid fuels, waste heat fuels, solar energy and electric power.

Compliance with the legal obligations to provide for the health and safety of workers within work health and safety regulations and legislation (Work Health and Safety Act 2011/Work Health and Safety Regulations 2011).

Design choices

Location on site

The location of the feed storage, handling and processing facilities on the overall feedlot site is critical. See *Section 2 – Feedlot site layout* for details about overall site layout considerations.

The most important considerations in selecting a location for these components are outlined below.

Accessibility and traffic flow

Grain and commodity receipt and storage facilities will need all-weather access for varying sizes of grain and commodity transport vehicles. The receipt and storage areas should be easily accessible and not affect the flow of operational traffic around the feedlot during placement and removal.



Grain handling and storage facilities need all-weather access, and should not interfere with operational traffic to pens.

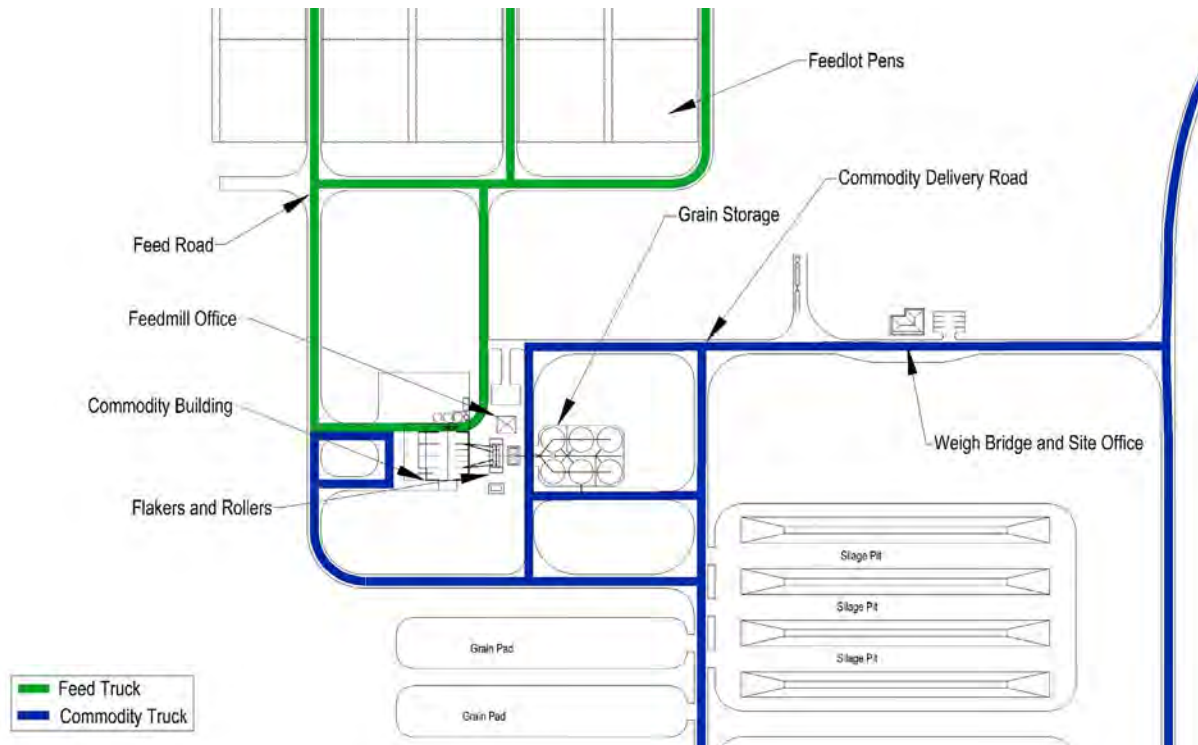

Figure 1. Paths for receipt and storage areas should not affect the flow of operational traffic around the feedlot.

Hay/straw storage areas should be located close to the feed processing facility/commodity shed, but at sufficient distance to minimise damage to infrastructure in the event the forage catches fire.

Grain and commodity transport vehicles require sufficient area for manoeuvring and loading/unloading. *Section 13 – Access and internal roads* provides further information about turning areas for typical feedlot vehicles.

The grain and commodity receipt and storage facilities should not be isolated from the feedlot during periods of severe wet weather or flooding.

The feed storage, handling and processing facilities should be integrated into the overall site layout to ensure good traffic flow around the site. The number of vehicle crossover/intersections should be minimised, and grain and commodity delivery vehicles paths should be separated from mixed ration delivery and livestock vehicles paths.

Traffic through the feed storage, handling and processing facilities should be limited to that directly involved with the feeding system. Other traffic should be directed around this area.

Separate paths for pedestrians will result in less interference and reduce potential for accidents.

Layout should allow feeding system vehicles to move in a forward direction, but with adequate space and reference markers if reversing is required. Storage locations for spare feeding equipment should not interfere with other vehicle or pedestrian traffic.

Proximity to production pens

Locating the feed preparation and commodity storage facilities near the production pens will reduce travel distances and minimise the



Feed mill (centre) located next to pens in a large feedlot.

cost of delivering feed to cattle. But some distance may be needed to ensure the ration is correctly mixed.

Services

Electricity will be the main source of power for grain handling, grain and roughage processing equipment and associated control systems. The electricity supply system must be appropriate and should take into consideration possible future expansion. Some storage areas (e.g. silage and hay) should not be situated near overhead power lines because of the risk from machinery associated with hay stacking (e.g. telescopic loaders). Some other forms of energy may require dedicated storage facilities, such as vessels for LP gas.

Water will be required for some grain processing methods, general cleaning purposes and fighting potential fires at hay stores and tub grinders.

Security and biosecurity

Visitor access to feed preparation and storage facilities should be restricted to reduce interference with feedlot operations, enhance safety and minimise the risk of product contamination.

Good biosecurity management will minimise feed contamination and the introduction and spread of noxious weeds.

Topography and drainage

The feed preparation and storage areas (e.g. silage pits) should be well drained and within the controlled drainage area of the feedlot.

Storage sites should be located well away from gullies or other places where storm water run-off can flow into feed preparation and storage areas. Storm water run-off should be diverted away from feed preparation and storage structures. This may require additional earthworks and/or control structures (e.g. culverts) at the time of site preparation.

Above or below ground constraints

Above or below ground constraints should be avoided. Above ground constraints include overhead power lines and trees. Below ground constraints include underground services, such as power, gas, water and telephone infrastructure.

Geotechnical

The physical properties of the soil at the site should be assessed to determine suitability for the storage base and building foundations. Avoid areas with rock, as these may increase costs of earthworks and building foundations.

Building separation and expansion

Space should be left for potential future expansion of the feed preparation and storage facility.

As hay/straw has a low bulk density and is a significant component of some feedlot diets, this should be stored near the feed processing area. However, a compromise between efficiency and safety requires a space of at least 15m between storage of this material and other buildings due to the potential risk of spontaneous combustion.



Feedlot undergoing expansion. The old feed preparation and storage area is next to existing pens and a new feed mill is being constructed central to both new and old pens.

Provision for fire protection (e.g. water hydrants) should also be considered for hay/straw storage areas.

Groundwater and surface water protection

The feed preparation and commodity storage facilities should be situated so that the risk of groundwater and surface water contamination is minimal. Some parts of the facilities, such as silage pits and liquid commodity storages, may need to be situated within the controlled drainage area of the feedlot (see *Section 10 – Pen and drainage systems*).



Large feed mill and commodity storage.

Flooding

The feed preparation and commodity storage facilities should be above a one in 100-year average recurrence interval (Q_{100}) flood height, unless protected by extra levees or similar structures. Local guidelines should be consulted to determine flood heights and if flood protection structures are permissible.

Provision for future expansion

Adequate room should be allowed for expansion and flexibility in the commodity storage and feed preparation facility design. Any plan based only on current needs will be difficult and expensive to expand. The rule of thumb is to undertake projections for feedlot needs out by five years and then double this. This leaves room for future expansion, even though the capital investment will cover immediate or near-term needs.

Facility design and layout

No single facility design will be suited to all feedlots. Each design must be evaluated on the basis of the requirements of an individual feedlot system. Important factors to consider are outlined below.

Nutritional considerations

- The effect of various ration designs on feed intake, rate of gain and feed efficiency. Will increased cattle performance more than offset any increase in capital and /or operating cost?
- Response of type of grain to processing. Is feed efficiency improved and/or feed consumption reduced?
- Uniformity and quality of finished product. Are the amounts of fines, separation, palatability, surface area, density or weight acceptable?
- Influence on beef quality. Is meat colour, fat colour or marbling affected?
- Can a range of different commodities and liquid feedstuffs be stored and various rations be produced and distributed?

Non-nutritional considerations

- The required design capacity of the system.
- The capital cost of the system.
- Size of feedlot. Is the feedlot large enough to justify investment in grain processing equipment?
- The estimated operating and maintenance costs of the proposed equipment.



Feed mill on small feedlot.

- The labour requirements to operate the system.
- Potential spoilage, wastage, losses and grain degradation.
- Inventory shrink.
- The process flow/layout requirements of the system.
- Access for commodity delivery and ration delivery vehicles. Ideally no reversing, which can be achieved with continuous loop roads.
- Protection from the weather.
- The level of automation possible and capital cost.
- Availability of services (e.g. water and mains power supply).
- Energy costs.
- Location of weighbridge (see *Section 27 – Truck weighbridges*).
- Ease and safety of operation.
- Operational safety of vehicles and people.
- Allowance for future expansion.
- Worker safety in terms of machine guards, walkway handrails and ladders.
- All foundations, concrete footings of heavy and/or silo-type structures designed by a geotechnical/structural engineer.
- The facility is located so that it is 200–300mm above natural surface to prevent entry of run-off.
- A suitable stormwater drainage system is provided around the facility.

Grain processing

Processing grain improves the digestibility of grain starch, feed efficiency and animal performance.

Grain processing methods can be broadly categorised as ‘wet’ (e.g. steam flaking, reconstitution or tempering) and ‘dry’ (rolling). Wet processing grain provides higher digestibility but is generally more expensive in terms of both capital and operational costs.

It may be more economical for smaller feedlots to obtain processed grain off site, either as a single commodity or in a pre-mixed ration. Larger feedlots need a processing system on site because of the large quantities of grain and other commodities required each day.

Grain processing methods are outlined in *Section 29*.

Grain storage and handling

Grain based rations typically contain more than 80% cereal grains on a dry matter basis. This means infrastructure associated with grain handling, storage and processing is a dominant component of the feed preparation facility.

Feedlots with on site feed processing require bulk storage and grain handling. Feedlots using commercial pre-mixed feed will also need on site bulk storage.

The storage and handling of grains requires systems that are compatible with each grain type and grain characteristic. Consideration should be given to whether the grains to be handled are whole grains, ground grains or processed grains.

Grain storage and handling is outlined in *Section 30*.



Roller mill for processing grain.



On-site grain storage facility.



Commodity storage shed with multiple storage bays.



Silage bunks.

Commodity storage and management

Facilities for the bulk storage and handling of feed commodities are needed when the ration is processed on site. The required type of storage ranges from dry feed commodity storage, fermented feeds (including silage and high moisture corn), by-products, processed roughage, liquid feedstuffs (such as molasses) and liquid supplements.

The bulk storage and handling of these feed commodities depends on many factors, including the range of commodities to be stored, the storage volume, the length of time the commodity is to be stored, the processing systems, the loading systems, the capital investment and the operational and maintenance costs of the facilities and equipment.

Commodity storage and management is outlined in *Section 31*.

Silage storage and management

Roughage, or fibre, is essential in the diet of lotfed cattle to enable normal rumen activity and may be provided as silage, hay or straw.

Silage typically contains higher levels of ME and CP than hay and is considered more palatable and digestible.

The silage making process, design and management of storage are critical to ensure the highest quality product, while minimising losses during storage and feeding. Good quality silage, correctly harvested and stored, maintains its quality for a long time.

Where the local environment or feed processing equipment is not suited to growing and/or handling silage, a feedlot may feed hay instead.

Silage storage and management is outlined in *Section 32*.

Hay and straw storage and management

Hay or straw is best fed in a chopped form when mixed with the grain and other commodities to ensure even intake of the concentrate and roughage.

In an on site feed processing facility, the relatively high percentage of roughage in a typical ration requires significant amounts of hay (and/or silage) to be stored on site.

Hay storage and management is outlined in *Section 33*.

Storage and handling of liquid feedstuffs

Liquid feedstuffs are used for conditioning rations, improving palatability, reducing dustiness and providing vitamin and mineral nutrients to cattle. Many liquid by-product materials are available, along with commercial liquid supplement products that incorporate minerals, vitamins and enzymes.

When liquid feeds are used in rations that are prepared on site, these need special equipment. This includes tanks and pumps designed to handle liquids.

Storage and management of liquid feedstuffs is outlined in *Section 34*.



Hay storage in open-sided shed.



Liquid supplement storage and dispensing system at small feedlot.

Ration mixing and delivery

In feedlot production, it is important to maximise dry matter intake. This is influenced by the method that is used for mixing and delivering feed to the feed bunk. The greatest control over intake can be achieved with a total mixed ration where feed ingredients are batched together by weight, then mixed and delivered to the cattle.

The components of the feeding system are feed storage areas, a feed batching and mixing area and equipment to deliver the feed to the pens. Mixing and delivery are usually performed with a tractor-trailer unit, or a truck with a mounted feed mixing/delivery bin. Stationary mixers and bulk feed delivery vehicles can also be used.

The equipment required for ration mixing and delivery depends on the type of ration preparation system (pre-mixed or prepared on site), the feeding system (bunk or self-feeders) and the feeding strategy (uniformity, quality of finished product and number of feed deliveries per day).

Ration mixing and delivery is outlined in *Section 35*.



Commodities and liquid supplements being loaded into feed-mixing and delivery truck.

Quick tips

- The site for on site feed storage and processing needs to consider traffic flow patterns and proximity to production pens.
- Allow sufficient area for vehicle manoeuvring and turnarounds.
- Evaluate the effects of the design and layout of on site feed storage and processing infrastructure on non-nutritional and nutritional considerations.
- Allow sufficient area for the storage of required volumes of roughage.
- Feed processing and delivery is the largest consumer of energy at a feedlot. Poor facility design and/or poor location can lead to increased operational costs.
- Locate hay storage and processing equipment away from the main feed preparation facility to minimise the risk of fire spreading.
- Consider future expansion of the feedlot capacity.

Further reading

- Appel, W B. 1985, Physical Properties of Feed Ingredients. Feed Manufacturing Technology III. pp 557-562 American Feed Industry Association. Arlington VA.
- Bath, D J. Dunbar, J. King, S. Berry, R O. Leonard, and S. Olbrich. 1990. Byproducts and unusual feedstuffs. Feedstuffs Reference Issue. Feedstuffs 62 (3 1):32-37.
- Campling, R C. 1991. Processing cereal grains for cattle – a review. Livestock Prod. Sci. 28:223-234.
- GRDC, 2012, Grain storage facilities Planning for efficiency and quality A Grains Industry Guide, Grains Research and Development Corporation , Canberra, ACT.
- Guyer, P Q, “G73-14 Grain Processing for Feedlot Cattle” (1973). Historical Materials from University of Nebraska-Lincoln Extension. Paper 249.
<http://digitalcommons.unl.edu/extensionhist/249>
- NRC 1984 “Nutrient Requirements of Beef Cattle”. National Academy Press.
- Macken, C N., Erickson, G E. and Klopfenstein, T J. 2006. The cost of corn processing for finishing cattle. The Professional Animal Scientist 22:23-32.
- Mathison et al. 1997. Effect of tempering and degree of processing of barley grain on the performance of feedlot cattle. Can. J. Anim. Sci. 77:.
- McEllhiney, R.R (ed) 1994, Feed Manufacturing Technology IV, American feed Industry Association Inc, Arlington, VA.
- McKinney, L.J. Grain processing: particle size reduction methods, Kansas State University Manhattan, KS
- Newman, C. 2003, Grain storage: Handling and maintenance, Farmnote No. 66/2003.
- Owens, F N., Secrist, D S., Hill, W J. and Gill, D R. 1997. The effect of grain source and grain processing of performance of feedlot cattle: A review. J. Anim. Sci. 78:868-879.
- Standards Australia 2010, AS 2628-2010 Sealed grain-storage silos - Sealing requirements for insect control
- Standards Australia 1989, AS 3729-1989 Farm Silos – Determination of storage capacity
- Standards Australia 2002, AS/NZS 1170.1:2002 Structural design actions – Permanent, imposed and other actions
- Standards Australia 2007, HB 867-2007 Supplementary information for design of farm structures
- Standards Australia 1992, AS1657-1992 Fixed platforms, walkways, stairways and ladders – Design, construction and installation.
- Standards Australia, 2009, AS3600-Concrete Structures
- Standards Australia 2003, AS3850- 2003 Tilt-up concrete construction
- Standards Australia 2004, AS1940-2004, The storage and handling of flammable and combustible liquids.
- Standards Australia 2002, AS/NZS 1596:2002 The storage and handling of LP Gas.
- Standards Australia, 1992, AS1657 -1992 Fixed platforms, walkways, stairways and ladders – Design, construction and installation.
- Standards Australia, 2009, AS2865-2009 Confined Spaces.
- Standards Australia (1998). Steel structures, AS 4100-1998, Sydney, NSW, Standards Australia.
- Standards Australia (2002). Dead and live load combinations, AS/NZS 1170.1-2002, Sydney, NSW, Standards Australia.
- Standards Australia (2005). Cold formed steel structures, AS/NZS 4600-2005, Sydney, NSW, Standards Australia.
- Standards Australia (2009). Concrete construction (including reinforced and prestressed concrete), AS 3600-2009, Sydney, NSW, Standards Australia.
- Standards Australia (2011). Masonry (including masonry-veneer, unreinforced masonry and reinforced masonry), AS 3700-2011, Sydney, NSW, Standards Australia.

- Standards Australia (2011). Wind Loads, AS 1170.2-2011, Sydney, NSW, Standards Australia.
- Theurer, C B (1986). "Grain processing effects on starch utilization by ruminants". J. Anim. Sci. 63:1649.
- Williams, D L, 1991, Handling and Storage of Alternative Feeds. University of Wisconsin-Madison.
- Zinn, R A. 1994. Influence of flake thickness on the feeding value of steamrolled wheat for feedlot cattle. J. Anim. Sci. 72:21-28.



FEEDLOT DESIGN AND CONSTRUCTION

29. Grain processing equipment

AUTHOR: Rod Davis

Introduction

Grain is processed mainly to improve the digestibility of its starch. Processing improves starch digestibility by 8–15%, speeds digestion through the gut, increases caloric intake, improves animal productivity and reduces costs of production.

Grain processing may also reduce manure production through lower intakes of feed dry matter per unit of liveweight gain, while reducing the level of undigested starch in the manure may also reduce odour.

Processing may simply crack, or open, the seed coat of the grain, or totally disrupt the grain kernel to expose the starch and increase its overall surface area.

Grain processing can be broadly categorised as ‘wet’ (e.g. steam flaking, reconstitution or tempering) or ‘dry’ (e.g. rolling or grinding).

Smaller feedlots may find it more economical to obtain processed grain off site, either as a single commodity or in the form of a pre-prepared ration or pre-mix. Larger feedlots need a processing system on site because of the large quantities of grain and other feed commodities required each day. Steam flaking and reconstitution systems require the most costly infrastructure, followed by tempering, rolling and grinding.

The decision about whether or not to process grain and, if so, what type of processing to use is an economic one based on the expected improvement in processing efficiency - compared to the capital and operational costs of the processing system.

Design objectives

The objectives of grain processing are to

- Enhance the nutritive value from a given type of grain.
- Break open the grain coating to expose the starch to direct contact with the digestive system.
- Improve the digestibility and/or caloric intake of existing grain starch.
- Improve the performance of cattle.
- Produce a good quality feed product.
- Reduce waste.

Design choices

The order of response of different grains to the extent of processing is sorghum > corn > barley > triticale > wheat. Sorghum and corn need more aggressive processing technologies, such as steam flaking or extended fermentation, and this requires higher capital and operational costs. The improvement in grain digestibility for wheat, triticale and barley is less - but still worthwhile. These grains may be effectively processed with rolling - with or without tempering.

Selection of a grain processing method also requires investigation into the ease of installation, quality assurance programs, customer perception (for a custom feedlot), grain inventories, roughage

inventories, diet consistency, available skilled people and accuracy of diet manufacturing. Although these factors do not usually fit into an economic evaluation, they may affect the overall decision.

For grain processing to be effective, the benefits of improved cattle performance must be balanced against the capital, operating and maintenance costs of the processing equipment, labour availability and skill level, energy efficiency and cattle management practices.

Grain processing techniques currently being practised, or available for use, in the Australian feedlot industry include dry rolling, grinding, tempering, steam flaking, reconstitution and high moisture grain. Dry rolling and grinding are the two most commonly used methods.

Processing methods are categorised in Table 1.

Table 1. Grain processing methods

Category	Processes				
Cold processing (no heat)	Grinding	Dry rolling			
Cold processing (with water)	Tempering				
Dry processing (with heat)	Micronising	Roasting	Popping	Exploding	Extruding
Hydrothermal (heat and water)	Steam flaking	Pelleting	Pressure flaking	Steam rolling	
Other	Reconstitution	High-moisture	Acid-treated	Chemical conditioning	Enzyme treatment

The four basic physical principles involved with breaking up the grain are

- Compression
- Impact
- Attrition
- Shear.

Most processing equipment uses a combination of these principles and this ultimately defines equipment suitability for certain situations.

Dry rolling

Grain is passed through rotating rollers that are usually grooved on the surface. The design of roller mills may vary depending on application. These are often named by the type of work they do, such as crackers, flakers, crushers or - more simply - rollers.

Grain passing between the rollers is sheared and compressed to break open the grain. The two rollers may operate at different speeds, depending on the function. The higher the speed differential, the greater the shear force applied to the grain. High oil seeds (e.g soybeans and canola) and high moisture grains are typically processed more easily with a higher differential speed, as shearing promotes self-cleaning between the rollers.

Roller mills produce particles with a cubic shape. Particle size varies from very small to very coarse and is influenced by roller weight, size of grooves, pressure and spacing, moisture content of the grain and rate of grain flow.

Dry rolling produces a less dusty product with a more uniform particle size than grinding, which shatters grain by impact.



A single electric belt-drive roller mill. Grain is conveyed to the hopper above the rollers and then to a holding bin.



Two single roller mills paired to increase capacity, or to mill two different grains at the same time.



A completely-sealed single roller.



An open spiral mixing auger to convey and mix the grain from the storage silo past the grain-wetting station to the tempering silos.

Dry rolling is considered to be more energy efficient than grinding, but energy efficiency depends on the operating speeds and target particle size.

Roller mills are more energy efficient for producing a product with large particle sizes (+1800 microns), but similar to hammer mills when the target particle size is 600 microns or below.

Roller mills with no roller speed differential are used to process tempered, steam-flaked or steam-rolled grain. Roller mills generally perform well with common grains, including corn, sorghum or wheat, depending on moisture content. However, they do not process fibrous materials efficiently and are not generally used for finely processing oats, barley and other fibrous grains or ingredients.

A roller mill with differential speed rollers can generally handle high moisture grain more readily than a hammermill, depending on the particle size desired. However, with more moisture, the endosperm of grain becomes elastic and absorbs the impact - or crushing energy - by deforming rather than shattering.

Grinding

A hammermill is usually used for grinding. There are many grinding chamber designs, including a half circle, a full circle, a teardrop and a split screen. Hammers, either fixed or free swinging, are attached to the rotor assembly. As the assembly rotates, the hammers impact and shatter the grain when they reach a critical 'tip speed'. Final particle size is determined by the hole size in the screen.

Hammermills produce more spherical particles than roller mills, but also generate more dust.

Grain moisture content will greatly affect the performance of a hammermill. With more moisture, the endosperm of grain becomes elastic and deforms rather than shatters. Heat due to friction will result in loss of moisture. Excessive moisture can clog the screens.

Factors influencing the fineness of the end product include screen size, hammermill size, power and speed, type of grain and moisture content of grain.

Tempering

Grain tempering uses water and time to temper (soften) the grain. Bran outer layers become more flexible and more readily separated from the endosperm during rolling.

An open spiral mixing auger conveys and mixes the grain from the in-loading storage silos, past a grain wetting station and to the tempering silos. At the grain wetting station, a precise amount of water (or water with surfactants) is added and then allowed to penetrate the grain in the tempering silo for up to 24 hours before rolling.

Tempering improves feed efficiency by 5–10%, increases roller efficiency and reduces dust.

Tempered grain has a moisture content of about 18% final moisture, but this may rise to 22% with further wet processing – such as steam flaking.

Steam flaking

Steam flaking uses moisture, heat and pressure to rupture the starch granules - rendering them more digestible. The degree of rupture depends on factors such as steaming time, temperature, grain moisture, roller size and gap between the rollers, processing rate and type and variety of grain.

Grain for steam flaking is first tempered, then passes through a steam chest (e.g. for 30–60 minutes at 95–110°C), before being flaked between two rotating corrugated rollers. The flakes are regularly sampled and weighed to determine density.

Steam flaked grain has a moisture content of about 22%, as much water can be lost as escaping steam. *Section 4 – Water requirements* outlines the estimated water requirements for grain processing.

Steam flaking requires energy to generate steam, drive the augers and for rolling. Steam may be generated using gas (LPG, natural or butane), coal or oil.

Steam generation is the single biggest consumer of energy in a feed processing facility and this may range from 240 to 315MJ/t grain processed.

Reconstitution

Reconstitution first came to the industry as a means of storing grains that were harvested with excessive moisture levels.

Reconstitution now adds water to the grain (reconstituting) to bring the moisture content to 28–32%.

The grain is first tempered before more moisture is added and the grain transferred to the reconstitution silos.

This high moisture grain must be stored in an airtight facility for at least 14 days before feeding – basically ensiling it to increase its digestibility. The grain is then rolled before being fed to animals.

Reconstituting grain uses less energy than steam flaking.

High moisture grain

High moisture grains can be an economical feed source because harvested grain yields are higher and there is no cost for drying the grain.

An optimum moisture content for corn and grain sorghum will allow easy harvest and low field loss, but is still adequate for correct fermentation and near maximum animal performance. Cereal grains are physiologically mature when the moisture content of the grain drops below 38–40% and will be acceptable for high moisture grain at between 25% and 33%.

Corn is the main grain harvested and stored in high moisture form, although sorghum and wheat have been used. Earlage is ensiled corn grain, cobs and - in some cases - a portion of the stalk.

High moisture grains that are ground may be stored in bunkers, pits, upright structures or even in large silage bags. Whole grains are often stored in upright oxygen-limiting structures.



Flaked grain.



Steam-flaking - grain is transferred to green holding bins above the steam chest. After conditioning in the steam chest, grain enters the flaking mill.



Boiler for the steam-flaking process. Steam generation is the largest single consumer of energy in a feed processing facility.



Characteristic blue-coloured 'Harvestore' silos are commonly used to reconstitute grain.

For storage in bunker pits, the preferred harvesting moisture level is above 27%. Corn stored in bunkers should be ground or rolled and then thoroughly packed into the pit to eliminate any trapped air. As correct packing depends on moisture and particle size, corn to be stored in a bunker silo can be coarsely ground with as much as 20% whole corn. A range of particle sizes will give the best compaction.

A disadvantage of high moisture grain is that the year's supply of product needs to be purchased, processed and stored at harvest time. Unlike silage, high moisture grain is an expensive commodity and this results in high inventory costs during the year.

See *Section 32 – Silage storage* for further information about silage storage design choices.

Quick tips

- For grain processing to be nutritionally and cost effective, any improved cattle performance must be balanced against the capital, operational and maintenance costs of the processing equipment, labour availability and skill level, energy efficiency and cattle management practices.
- Each processing method differs in nutritional efficacy.
- Depending on type, grain can be rolled or ground to improve nutrient digestibility and cattle performance.
- Roller mills are less efficient at processing fibrous materials and are not generally used for finely processing oats, barley or other fibrous ingredients.
- Steam flaking uses significant energy to generate steam.
- Reconstituting grain has high capital, but low operational, costs. It requires a higher level of management to ensure a consistent quality product than steam flaking.
- Processing and storage of high moisture grain can result in high inventory costs.

Further reading

- Campling, R.C. 1991. Processing cereal grains for cattle – a review. *Livestock Prod. Sci.* 28:223-234.
- Davis, R.J., Weidemann, S.G. and Watts, P.J. 2008, Quantifying the Water and Energy Usage of Individual Activities within Australian Feedlots, Part B Report: Energy Usage at Australian Feedlots 2008, Project B.FLT.0350 Final Report, Sydney, NSW.
- Davis, R.J., Weidemann, S.G. and Muller, B.D. 2009, Quantifying the Water and Energy Usage of Individual Activities within Australian Feedlots, Part B Report: Energy Usage at Australian Feedlots 2008-2009, Project B.FLT.0339 Final Report, Sydney, NSW.
- Gill, D.R. 1970. "Feed Analysis". GPE-1800, Oklahoma State University.
- Gill, D.R. 1984. Feed Grains Utilization Symposium. Texas Tech University.
- Guyer, Paul Q., "G73-14 Grain Processing for Feedlot Cattle" (1973). Historical Materials from University of Nebraska-Lincoln Extension. Paper 249. <http://digitalcommons.unl.edu/extensionhist/249>
- NRC 1984 "Nutrient Requirements of Beef Cattle". National Academy Press.
- Macken, C.N., Erickson, G.E. and Klopfenstein, T.J. 2006. The cost of corn processing for finishing cattle. *The Professional Animal Scientist* 22:23-32.
- Mathison et al. 1997. Effect of tempering and degree of processing of barley grain on the performance of feedlot cattle. *Can. J. Anim. Sci.* 77:.
- McElhiney, R.R. (ed) 1994, Feed Manufacturing Technology IV, American feed Industry Association Inc, Arlington, VA.
- McKinney, L.J. Grain processing: particle size reduction methods, Kansas State University Manhattan, KS
- MLA, 2012, A Framework for Water and Energy Monitoring and Efficiency in Feedlots, Fact Sheet Series based on MLA funded research in projects FLOT.328, B.FLT.0339 and B.FLT.0350, Sydney, NSW.
- Owens, F.N., Secrist, D.S., Hill, W. J. and Gill, D.R. 1997. The effect of grain source and grain processing of performance of feedlot cattle: A review. *J. Anim. Sci.* 78:868-879.
- Rode, L. and Beauchemin, K. 1998. New Ideas for Processing Barley. Proceeding International Beef Symposium. Lethbridge, January, 1998.
- Theurer, C.B. (1986). "Grain processing effects on starch utilization by ruminants". *J. Anim. Sci.* 63:1649.
- Swingle, R, Spencer, R., Theurer, B. and Urias, A. (1993). "Sorghum grain flake density and source of roughage in feedlot diets". Research update. Southwest Nutrition Conference. p. 38.
- Zinn, R.A. 1993. Influence of processing on the comparative feeding value of barley for feedlot cattle. *J. Anim. Sci.* 71:3-10.
- Zinn, R.A. 1994. Influence of flake thickness on the feeding value of steamrolled wheat for feedlot cattle. *J. Anim. Sci.* 72:21-28.



FEEDLOT DESIGN AND CONSTRUCTION

30. Grain storage and handling

AUTHORS: Rod Davis and Ross Stafford

Introduction

The infrastructure associated with grain storage and handling is a major component of the feed management system when rations are prepared on site. On site infrastructure for bulk storage and handling may also be required at feedlots that are using commercial pre-prepared or pre-mixed feed.

Facilities for on site grain storage and handling, or for pre-mixed feed storage, must be adequate to ensure that no component of the feed supply is depleted, forcing the ration to be altered unnecessarily or at short notice. Significant on site storage also allows for opportunity purchases of grain and provides for any extended interruption in grain deliveries.

A grain storage and handling facility includes grain receipt, grain movement, grain cleaning, reclaim, storage and possibly drying and cleaning operations. This is a major investment and the whole system must be carefully planned.

Facilities for the storage and handling of grains (and processed grains) should be compatible for whole grains, ground grains or processed grains.

Design objectives

Grain storage and handling facilities should be designed, constructed and maintained to ensure that

- An overall system is developed that accommodates the grain storage and handling operational requirements of the feedlot.
- Adequate volume of storage is available to allow strategic purchasing of commodities.
- There is adequate volume of storage to ensure feed is available to cattle following any likely contingency (e.g. local flooding).
- Process flow and layout of the distribution system is suitable for the types and characteristics of the materials to be handled and the operational requirements of the facility.
- Quality of the grain handled is not compromised by contamination by insects or rodents.
- Personnel, equipment and overall facility safety issues are implemented.

Mandatory requirements

Compliance with

- AS1657 -1992 Fixed platforms, walkways, stairways and ladders – Design, construction and installation for access, stairs, landings etc on grain storage and handling equipment.
- AS2865-2009 Confined Spaces for confined spaces entry requirements.

Design choices

Planning should include strategic planning, economic factors, location on site and facility layout and allow for potential facility expansion, rather than new construction.

Strategic planning

For optimal long term feedlot profitability, capital spending on new facilities needs to reflect the strategic planning objectives of the feedlot.

Economic considerations

Local issues, such as grain types and volumes produced in a particular geographic location, will directly affect facility design.

Site location

Selection of an appropriate site within the overall layout of the feedlot will optimise the efficiency of feed preparation and delivery systems. Site considerations are discussed in *Section 2 – Feedlot site layout* and *Section 28 – Feed preparation and storage*.

Facility layout

The type of construction and the amount of available land may determine the physical layout of the facility.

The relative location of the areas designated for commodity receipt, feed preparation, loading and feeding out will affect the operational efficiency and costs of running the facility.

Design considerations for each storage and handling facility should include

- Storage capacity
- Handling rates
- Capital cost
- Short-term (e.g. pad/bunker) versus long-term (e.g. silos) infrastructure
- Allowable level of grain degradation
- Protection of grain from spoiling, insects, pests and vermin
- Maintenance requirements
- Process flow/layout requirements
- Automation
- Lot identity preservation
- Built in flexibility
- Expected life of the system
- Safety (e.g. dust explosions).

Grain characteristics

Grains can be divided into three groups: cereals (maize, wheat, barley, sorghum, rice); pulses (lupins, beans, peas); and oilseeds (soybeans, sunflower, linseed, canola).

Different grains and grain types have a range of characteristics that can affect the type of distribution system selected and the components required in the distribution system. These characteristics include moisture content, weight of the grains, angle of repose of the grains, abrasion of the grains against contact surfaces and ease of flow of the grains. A brief description of moisture content and angle of repose follows.



Gravity fall of grain through tubes from the bucket elevator to cone-bottom silos using a diverter. Greater height of bucket elevator is required for gravity fall of grain.

Moisture content

Moisture content in grain is defined as the amount of water that is absorbed into the grain kernel as a percentage of the total weight of the grain kernel.

The moisture content of a grain is typically provided on a ‘wet basis’ (wb) and is calculated as

$$\text{Moisture content wb} = \frac{\text{Weight of moisture}}{\text{Weight of wet sample}} \times 100$$

Standard grain grades with moisture contents of 13–18% do not usually cause material flow problems. But high moisture content grain, when coupled with high foreign material contents and fines, can lead to material flow and handling problems. Moisture content of the grain can change with the environment in which it is stored and this should be monitored to help ensure the overall condition of the grain.

Figure 1 illustrates the potential issues with stored grain at a range of temperatures and moisture contents. As the temperature rises, the safe level of moisture in the grain must be reduced for good quality storage.

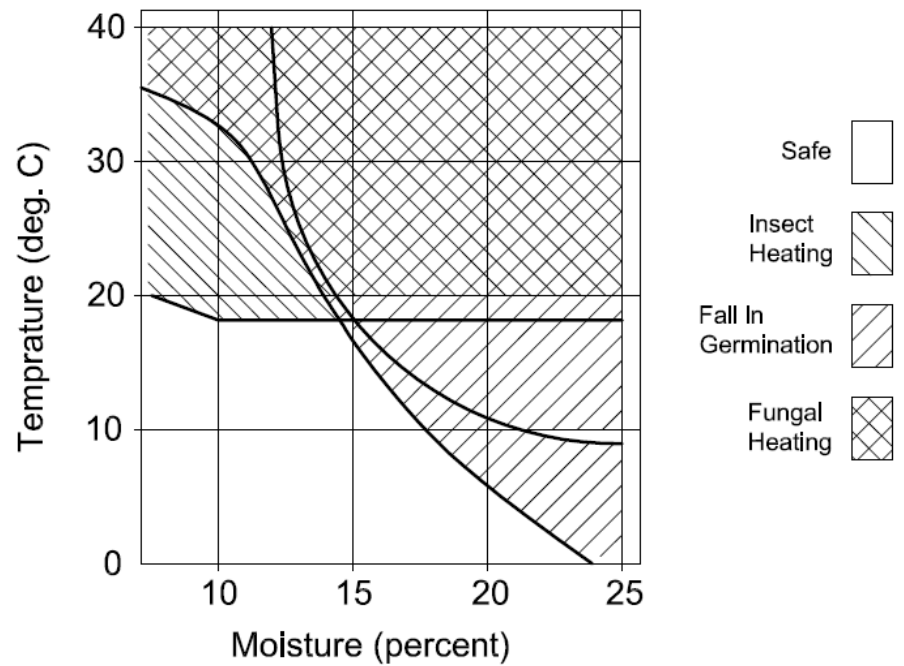

Figure 1. Effects in storage at different temperatures and moisture content.

Angle of repose

The angle of repose is the greatest angle from the horizontal to which a grain can be raised without it sliding or rolling on itself in an unconsolidated form. This determines whether a grain mass will flow by gravity, or need outside forces to move. It will determine the minimum spouting angles for gravity flow. The angle of repose of grains varies with type, variety, moisture content, quality and level of contamination.

Angle of Repose for common grains is shown in Table 1. These angles will increase for wet grain and may also vary slightly

depending on grain quality and its admixture content. The grain coefficients can be used for calculating volume of grain when piled at a natural angle of repose.

Table 1. Angle of repose for common grains

Grain	Angle (degrees)
Barley	28
Wheat	25
Sorghum	30
Sunflower	30
Corn	23
Oats	28
Soybeans	25

Abrasion

All grains will wear the surfaces that are in contact with flow. The amount of wear will vary according to the type of grain, the volume of grain, speed of grain, the impact of grain streams on surfaces and the slope of the contact surface. All aspects of the distribution system are affected by these characteristics. When analysing systems, components such as spouting, transitions, gates, valves, conveyors and future access to these components must be designed into the system for maintenance requirements.

Corrosion

Wet grains, ground processed grains and chemically treated grains can corrode standard carbon steel fabrications. Each grain type to be handled must be checked to determine if stainless steel is needed, or will reduce possible life cycle costs. If water wash down, or clean-in-place systems are required, materials used for fabrication in the distribution system should be considered.

Grain storage

All storage systems must be designed to adequately protect and preserve the quality of the grain. Whole grain can sprout under certain conditions and will also attract moulds, insects and rodents. In addition, the storage of grain presents several safety issues.

Grain storage systems come in a range of shapes and sizes, The design of a grain storage facility should be based on

- Length of time for storage – temporary or long-term.
- Degree of segregation of different types of grain.
- Identity preservation requirements.
- Expected useful life of the structure.

Grain storage and handling options currently available for the Australian feedlot industry are outlined below.

Long term storage

In general, grain in long term storage should be held cool and dry. Options include smooth wall steel silos, corrugated steel silos



An arrangement of cone-bottom silos with a mobile auger for filling.



Large-capacity flat-bottomed silos. Note safety handrails are included on the walkway.



Live bottoms on cone-bottom silos provide a wider opening for handling products, such as moist grain, that tend to bridge.

bins, concrete silos and underground pits. Steel silos are the most common method of long term storage for grain at feedlots, but underground pit storage is an alternative for longer term storage.

Silos

Sizes and construction

Silos are available in a variety of sizes, configurations and materials, including flat bottom or cone base, gas-tight sealable or non-sealed, aerated and non-aerated.

Silos can be built on site or transported fully constructed and ready to stand.

The size of fully constructed, transportable silos is limited by road transport regulations in each State. As a general guide, fully constructed silos can be up to 140t capacity. Most smaller (50–70t) cone-bottom silos are generally prefabricated and transported.

Cone-bottom silos are self-emptying, but are limited to capacities of less than 300t.

Feedlots may require air-tight/gas-tight storage facilities of higher capacity. But the increased surface area of a larger silo requires more sheet metal joints, providing more opportunity for air or gas to escape.

Capacity is commonly quoted in tonnes, but may also be quoted as cubic metres (m³). To determine tonnage capacity, multiply the cubic capacity by the bulk density of the grain (see Table 2).

Table 2. Grain bulk densities

Grain	Bulk density (t/m ³)
Wheat	0.80
Canola	0.67
Barley	0.68
Triticale	0.62
Sorghum	0.73
Maize	0.72
Lupins	0.80
Mung beans	0.75
Sunflower seed	0.42
Cotton seed	0.40

Structural design considerations

Loads put on grain storage and handling facilities are unique and structures should be designed by a specialist structural engineer.

Foundations

Foundations for elevated silos are different to those for general building construction because of the large loads involved.

The first step in establishing a silo is to construct a good quality pad. These structures are engineered to support grain in a vertical plane, with pressure exerted and distributed evenly around the base

support frame. If the pad is not level, the weight of the grain will place excessive stresses on the lower sheets of the silo and possibly twist the base frame - deforming the silo.

The soil engineering requirements for most elevated silos should be determined by a consulting geotechnical engineer.

Safety

Safety issues associated with grain storage and handling include working at heights, working in confined spaces, entering grain silos while being emptied (grain entrapment) and dust explosions.

Silo designs now incorporate ground operated lids, caged ladders, platforms and top rails to minimise the risk of operators falling. Facilities for harness attachments, which should be worn by all operators who are climbing and entering silos, should also be fitted. Silos are classified as confined spaces and correct procedures need to be followed prior to entry.

Temporary storage

Temporary grain storage may be necessary when on site storage capacities are likely to be exceeded during unusually large harvests, or for opportunity storing/buying of large quantities of grain at an economical price.

Temporary storage may be a ground dump with or without a cover. Covered ground dumps include grain bags, sheds and bunkers.

Ground dump without a cover

An uncovered pile of grain is the cheapest form of temporary grain storage, but risks damage by water, insects, birds, animals and moulds. Grain should be moved from this type of dump as quickly as possible to minimise damage.

The dump site should be higher than the surrounding area, well drained, well above the water table and formed with a slight slope away from the centre of the site to prevent water damage at the base of the grain pile. Water must be able to drain away freely from the base of the pile.

The site should be graded and sticks and rocks removed before being hard packed. A hard packed base helps drainage, provides a compact durable base for operation of filling and emptying machines and for minimising spoilage. A long fall slope of 1:200 to 1:300 (0.3%–0.5%) and a cross fall slope of 1:50 (2%) are necessary for drainage.

The pile should be built uniformly to achieve a maximum grain surface slope (angle of repose). This may be accomplished by keeping the drop distance from the grain elevator to the pile at a minimum. The maximum angle of repose and pile height occurs when grain rolls down the side of the pile.

The surface should be trimmed to produce a smooth, peaked profile - without hills and troughs that will collect rainwater and encourage sprouting and mould growth. A temporary fence around the pile helps to keep out people and animals.

Quality can deteriorate rapidly in uncovered grain piles. Grain temperature and moisture content should be checked at several locations every two or three weeks.



Safety - confined space warning on silo.



Temporary grain stockpile in a bunker storage with pre-fabricated steel sides.



Covered grain stockpile in a bunker storage with small earthen walls.

Uncovered dumps are not advisable for storing grain for feeding to feedlot cattle.

Ground dump with a cover

Pad storages, or bunkers, are ground dumps covered with protective sheeting. A waterproof plastic lining laid across the floor and walls of the pad will prevent moisture entering from below and contamination by soil.

Pad or bunker storage requires careful site preparation, labour for handling large tarp covers and machinery to move grain on and off the grain pile.

A pad should preferably be orientated so that the closed end faces into the prevailing wind to reduce problems in handling the cover sheets.

The site should be graded with a floor slope of at least 1 in 200 towards the open end, with sticks and rocks removed. A hard packed base assists drainage, provides a compact durable base for operation of filling and emptying machines and accessibility even when wet.

A drainage area around the pad is essential to divert run-off from the protective sheeting.

Effective treatment of insect infestation is difficult in bunkers, as fumigation relies on a sealed gas-tight storage.

The height to which handling equipment can stack grain, the retaining wall height and the angle of repose of the grain will determine the width of the bunker.

The formula below (along with information in Table 1), can be used to calculate capacities of pad storage for various grain types.

Retaining walls

The capacity of a pad, or bunker, storage facility is increased with the use of retaining walls. These are usually arranged in a U-shape around three edges of the pad site, with an open end for access when filling or emptying.

Retaining walls may be formed from earth or concrete pre-cast or cast in-situ and should be designed and constructed to support the force of the grain exerted on the wall.

Earth walls can be formed using soil from the area immediately outside of the pad perimeter. This creates a channel around the pad, which can be used to drain run-off from the protective sheeting. The soil should be compacted during formation of the walls.

Earth walls are typically about 0.5m high and 1.5m wide at the base, with a 45° side slope. Walls higher than 0.5m will need to be designed and constructed to ensure slope stability.

Lining and cover sheeting

The protective cover sheet should be gas-tight to allow fumigation and should resist water penetration, puncturing and UV breakdown. Pads are best covered with a single piece of prefabricated cover, as joining methods require specialised techniques and equipment.

Materials include woven polyethylene or PVC coated polyester. Woven polyethylene is cheaper, lighter, more easily handled and



Safety warning – Fumigation with toxic gas.

will last for several seasons if handled carefully - but may not be as durable as PVC covers. Floors are commonly lined with woven polyethylene or black plastic film.

The cover and floor liner sheets must be sealed to exclude insects, rodents and water and allow effective fumigation. A camber in the surface material around the storage will drain water away.

Sheets can be sealed simply by burying the floor liner and cover in a backfilled trench about 250mm deep at the base of the earth walls. Once buried, the remaining edge of the sheets should be folded back over the soil backfill to minimise erosion of the backfill.

The cover should be ballasted, or tied down, to prevent damage due to billowing and flapping in the wind. Avoid using objects with sharp projections that could puncture the cover. Place wear patches under ropes or ballast objects to minimise abrasion due to wind movement. See *Section 32 – Silage storage and management*.

The cover should be examined periodically for perforations from animals, birds, rodents, wear points, wind or vandalism. Any damage should be repaired.

Sheds

Sheds can provide multi-purpose storage of other products, including commodities, fertiliser and machinery. Good hygiene must be practiced to avoid the risk of contaminating the grain. As a permanent infrastructure investment, sheds can be continually used and have a retained value on-farm.

Unloading grain into the shed and loading grain out of the shed commonly requires an auger, or belt conveyor, direct to or from the delivery truck.

Effective treatment of insect infestation is difficult in sheds.

Design and construction of structures for commodity storage is provided in *Section 31 – Commodity storage*.

Grain bags

Seamless grain bags generally range from 40 to 90m in length and have a 100 to 300t capacity, depending on bag size, the type of grain and how much the bag is stretched during filling. These are best used only for a few months to store grain. They are not suitable for canola or high value legumes.

After the bag is sealed, the moisture content and temperature of the enclosed grain interact to produce carbon dioxide and deplete oxygen. These conditions suppress any fungi or insects and maintain quality. However, a moisture content greater than 12.5% may spoil grain quality and increases the risk of grain swelling and splitting the bag.

Aeration cooling is not yet proven with grain bags.

Grain bags must be installed on a well prepared site and away from bird habitats, including trees and water sources. Site preparation as outlined for pad storage should be followed. An elevated, well-drained pad provides optimal results – with no rocks that can tear the grain bags as they are being filled and unloaded.



Ground dump being covered.



Grain can be temporarily stored under cover. This grain storage shed has a permanently mounted central discharge auger for loading the shed.



A permanently situated, drive-over grain receival hopper for fast unloading of trucks.



A drive-over receival grid with raised covering doors. A screw conveyor transfers grain from the hopper to a grain conditioner or scalper.



Grain scalper and cyclone to remove unwanted vegetable material and dust.

Animals should be kept away from storage bags using temporary fencing.

Grain bags can be used only once, as they are usually irreparably damaged when being emptied. Care must be taken in disposing of the used bag material.

Grain storage management

Good hygiene in grain handling and storage premises will maintain the quality of the products handled.

Problems with grain caking on silo walls, being damp and mouldy in the base of the store and sprouting in the headspace are caused by poor grain management or poor maintenance of the grain store. Other problems have been reported with lupins or peas stored in old silos, where walls have buckled or compressed from the greater pressure exerted by the round seeds. In extreme cases, the silo has collapsed.

Good hygiene can be achieved by ensuring that storages facilitate are

- Easily inspected.
- Regularly serviced for equipment maintenance.
- Cleaned of grain residues, particularly in sheds, around silos, in augers and in silos after emptying.

Good storage design should be complemented by

- Correct training of people in safety and hygiene-related issues.
- Regular monitoring.
- Establishing a system for recording and checking hygiene procedures.
- Developing action strategies if contamination is to occur.

Grain handling

Grain handling and conveyor systems should be designed to minimise damage to grain.

Pulses are more susceptible to impact damage than cereals and should not be moved in pneumatic grain conveyors, as the impact speed of grain is higher than the critical 12m/s. Augers smaller than 125mm in diameter should also be avoided with pulses. Augers should be run full, and preferably slowly, to reduce grain damage. It is easier to modulate auger speed if driven by petrol/diesel engines, than by electric motors.

A wide variety of grain handling equipment and systems is used in the Australian feedlot industry.

Grain receival hoppers

A high capacity receival system is needed for efficient transfer of grain from trucks, or tractors and trailers. Ideally, it should be possible to deposit a trailer load and pull away from the unloading area within minutes. An in ground receival hopper is typically fitted with a screw conveyor, or auger, to raise grain for conditioning or storage.

Grain conditioning and metal detection

Foreign materials and dust must be removed to eliminate problems further down the grain storage and handling system. A grain conditioner, or scalper, removes foreign particles, weed seeds, small

size grain, straw and husk. A dust extraction and collection system prevents dust entering the environment.

All foreign metal objects must be detected and removed before they can cause damage. A permanent - or electro -magnet can be located in the chute that feeds the grain conditioner, but needs to be checked and cleaned regularly.

Belt and bucket elevators

Bucket elevators are used mainly to lift grain vertically to silos or other storages. These usually deliver the grain directly into silos using diverters that direct grain into a gravity chute to the selected silo, or by using belted conveyors to transfer grain horizontally to the various silos.

A flat belt between crowned pulleys at the top and bottom of the casing has small buckets attached at regular intervals to carry the grain from the elevator bottom to the top. The capacity depends on the volume of the buckets, the spacing and the speed of the belt. Elevators up to 20m high and with a capacity of 50t per hour are available.

Bucket elevators are self-cleaning by design and are typically fixed in position.

Auger (screw conveyors)

Auger elevators are one of the cheapest methods of elevating grain and can be fixed or portable. These are available in a wide range of lengths and capacities and are usually powered by an electric motor. They are comparatively light in weight, dependable in operation and popular due to good portability. Long augers may be mounted on wheels for easy transport. The angle of operation is adjustable, but the capacity declines as the auger is raised. High moisture content in grain also reduces the capacity of the auger. Old augers with worn flighting can damage split-prone grain.

Belt conveyors

Belt conveyors are typically used to transfer grain horizontally. Inclines up to 15° are possible - and even up to 30° with ribs fitted to the belt. Belt conveyor capacity is high and grain can be loaded or unloaded anywhere along the belt. Belt conveyors do not damage the grain and raise little dust.

Drag chain conveyor

Drag chain conveyors, or paddle conveyors, use a series of paddles fixed to a loop of chain moving inside a fully enclosed conduit. The circular paddles are sized to fit snugly in the conduit. This fully enclosed system prevents dust in a building or other space. Drag chains can move grain at any angle, including horizontal, and are largely self-cleaning, although corners of the chain loop will typically require attention. Drag chain conveyors are a permanent installation, but can be easily extended for facility expansion.

Mobile equipment

Mobile augers, mobile belt conveyors, grain throwers and pneumatic conveyors may be used to load grain into storage facilities.



Receival grid, grain handling and cone-bottom silos. The grain is conveyed from the receival grid to a bucket elevator, with gravity fall to a horizontal conveyor for transport to the silo of choice. The height of the bucket elevator is reduced by using a horizontal silo loading conveyor.



Bucket elevator, diverter and cone-bottom silos. The feed delivery vehicle is loaded directly from the elevated silos.



A tractor powered auger used for loading these flat-bottom silos. Note the PTO-powered auger at the base of the silo for unloading grain from the silo.

Mobile augers or belt conveyors, with fixed and guarded cross-sweeps, or a front-end loader can be used to empty the pad. Pneumatic conveyors also suit this job and allow easy final clean up of grain.

Operators using mobile elevating equipment must be made aware of any overhead power lines to prevent electrocution.

Automation

Controls, instrumentation and automation systems are key elements in the overall distribution system. The automation system is governed by the overall facility design and operational requirements.

Each individually controlled device can be linked into a main PLC, enabling coordination of the controls between various pieces of equipment.

Quick tips

- Layout and design is a key consideration in the operation of a functional grain storage and handling facility.
- Grain characteristics, including type of grain, moisture content, weight, angle of repose, abrasion of the grains against contact surfaces and flowability, should be considered in the design and selection of a storage and distribution system and the individual components.
- All storage systems must be designed to adequately protect and preserve the quality of the grain.
- Good hygiene in grain handling and storage will maintain the quality of the products handled.
- Grain segregation requirements may determine the number of silos and storage capacity. A larger number of smaller silos allow better segregation.
- Access and safety features, including roof rails, ladder lockouts, platforms and ladder cages on silos and elevated handling systems, are mandatory.
- Road loops that minimise the need for reversing can make loading and unloading quicker and safer.
- Sites for pad, bunker or grain bags should be graded and debris, sticks and rocks removed. A floor slope is necessary for drainage. A hard-packed base helps drainage and provides a compact durable base for filling and emptying operations.

Further reading

- Andrews, A. and Jensen, T. 1998, Storing, handling & drying grain: A management guide for farms, Department of Primary Industries Queensland QI 96081.
- Australian Building Codes Board (ABCB), 2013, Volumes One and Two of the National Construction Code of Australia.
- GRDC, 2012, Grain storage facilities Planning for efficiency and quality A Grains Industry Guide, Grains Research and Development Corporation , Canberra, ACT.
- Newman, C. 2003, Stored grain management : Underground storage of grain, Farmnote No. 70/2003.
- Newman, C. 2003, Grain storage: Handling and maintenance, Farmnote No. 66/2003.
- Newman, C. 2003, Grain storage : Maintaining grain quality, Farmnote No. 65/2003.
- Newman, C. 2002, Aeration - for preserving grain quality, Farmnote No. 24/2002.
- Standards Australia, 2010, AS 2628-2010 Sealed grain-storage silos - Sealing requirements for insect control
- Standards Australia, 2008, AS 2476-2008 General fumigation procedures
- Standards Australia, 1989 AS 3729-1989 Farm Silos – Determination of storage capacity
- Standards Australia, 2002, AS/NZS 1170.1:2002 Structural design actions – Permanent, imposed and other actions
- Standards Australia, 2007, HB 867-2007 Supplementary information for design of farm structures



FEEDLOT DESIGN AND CONSTRUCTION

31. Commodity storage

AUTHORS: Rod Davis and Ross Stafford

Introduction

Dry and wet feed commodities may include dry grains, processed grains, high moisture grains, roughages and by-products from feed or food processing operations, fermented feeds, liquid feeds and wet or dry vitamin or mineral supplements.

This section focuses on the storage of bulk feed commodities that are typically by-products from processes that extract, convert or separate compounds in various segments of the food or feed industry.

Examples include hulls and meals from oilseed extraction, distillers grains from beverage or fuel ethanol production, brans, grain germs and chaff from various grain milling operations, fermented sugars, starches and bran from sweetener production and pulps from sweetener or juice production.

Ethanol production has increased the availability of dry and wet distiller grains for feedlot cattle feed. Dried distiller grains are relatively easy to handle and store, but wet distiller grains present challenges for storage, handling and preservation.

Another class of feed commodities includes various industrial food wastes, such as potato wastes, snack food waste (e.g. corn and potato chips), fruit and vegetable cannery waste and bakery wastes (e.g. bread).

For bulk storage and handling of these feed commodities, factors that need to be considered include storage volumes, shelf life of the product, any further processing required, delivery systems, loading systems, labour, capital investment and maintenance of the facilities and equipment.

Design objectives

Commodity storage facilities should be designed and constructed to

- Provide a functional space for the storage of a range of feed commodities.
- Provide separate areas to store each feed commodity.
- Provide adequate storage space for a given volume of each feed commodity, considering the shelf life and seasonal supply.
- Provide enough storage to meet the daily demands of the feedlot.
- Provide moisture protection for dry feed commodities.
- Provide adequate access and flexibility for various types of vehicles for delivery and handling of feed commodities.
- Minimise wastage and spoilage of feed commodities.

Mandatory requirements

The building elements, such as concrete footings, floor slabs and steel structures, are required to meet the structural provisions of the Building Code of Australia (BCA) and local building regulations and be designed in accordance with the relevant Australian standards.

Design choices

Major considerations when designing a commodity storage facility include

- Flexibility – the system should allow easy changes in feeding practices or ration ingredients.
- Physical characteristics of the feedstuffs– these will affect the handling and storage requirements.
- Site location – a single site versus multiple sites.
- Storage options – silos, slabs or flat-bottomed storage sheds.
- Ease of operation – for convenient movement of machinery to feed out the commodities.
- Economy – lowest cost combination of components, with effective performance and minimal wastage.
- Maintenance – provision for alternative methods to keep feeding, even when a part or component is out of service.
- Dependability – dependability from simplicity, as more mechanisation increases the potential for breakdowns and costs to repair.
- Safety – minimise hazards and risks to personnel and animals.
- Plan for expansion – allow for possible increase in capacity.

Physical characteristics

The physical characteristics (e.g. bulk density, angle of repose and particle dimensions) of feed commodities vary. The bulk density (weight/unit volume - or kg/m³), or specific volume (volume/unit weight - or m³/kg), of a feed commodity can be used to determine the volume needed for storage.

Table 1. Bulk density for common feed commodities.

Feed commodity	Bulk density kg/m ³	Specific volume m ³ /kg
Dry brewers grain	240	0.004
Wet brewers grain	800	0.001
Canola	620	0.002
Cottonseed, hulls	192	0.005
Cottonseed, meal	593	0.002
Hominy meal	449	0.002
Linseed, whole	753	0.001
Linseed, meal	513	0.002
Lupins	770	0.001
Peanuts, shelled	641	0.002
Peanuts, not shelled	272	0.004
Soymeal	650	0.002
Sunflower meal	416	0.002
Rice hulls	288	0.003
White fluffy cottonseed	401	0.002



Sufficient space for easy access and tipping for large trucks and semi-trailers.



Locating the commodity storage facility adjacent to the feed mill allows processed grain to be discharged directly into a storage bay.



Tub grinder sited adjacent to, but outside, commodity shed.

Other physical characteristics, such as high moisture content, increase the likelihood of feed quality losses, deterioration or spoilage. The physical properties of hay play a role when these are used in grinder or mixing systems.

Single or multiple site

A single site for storage of all feeds is preferred, as it allows feed transport vehicles from both on and off the feedlot and feed mixing and delivery vehicles to be contained in a designated area. The person responsible for feeding can load the feed truck or mixer with a minimal amount of travel distance to ingredients, making mixing and feeding more efficient and effective.

The feed out loader is also readily available to move bulk commodity deliveries if required. See *Section 2 – Feedlot site layout* for design considerations for the overall site layout.

Matching storage and equipment

Sufficient storage space should be provided for equipment such as feed mixers, tub grinders, tractors and loaders that are used for processing, delivering feed commodities, filling storage bays and feed trucks.

This storage may be in an adjacent machinery storage area, a section of the commodity storage building or another building. Sufficient space is needed for easy access and tipping for large trucks and semi-trailers that deliver feed commodities.

Space may be available, or may be adapted from other buildings already on the site.

Location

The location of the commodity storage facility is integral to the efficiency of the feed preparation, storage and delivery system. An ideal location will provide easy access for delivery of purchased feed commodities, easy filling of grain silos and/or storage bays, convenient movement between silos, bulk storage and efficient loading of feed trucks or mixers.

In feedlots with an on site feed mill, the commodity storage facility should always be located adjacent to the feed mill so that processed grain can be discharged directly into one or more storage bays.

Site considerations are discussed in *Section 28 – Feed preparation and storage* and *Section 2 – Feedlot site layout*.

Delivery vehicles should be able to enter, unload and leave with minimal manoeuvring. Delivery of feedstuffs into the commodity shed should not interfere with the ration mixing and delivery process. Roadways and aisles should be wide enough to allow for unhindered movement of feed system vehicles.

Rodent control

Rodents cannot be completely eliminated, but some steps can be taken to limit the appeal of the commodity storage facility. A narrow trench, about 30cm deep and filled with medium sized gravel, placed around building foundations and slabs will discourage rodents from burrowing.

Typical daily ‘house keeping’ should keep the facility relatively clean, and the area surrounding it should be regularly mowed/tidied. Safe rodent baits will help to limit habitat.

Bird problems can be reduced by limiting the available roosting area, such as open trusses and knee braces. Small bird wire netting can be used to screen off these areas.

Storage options

The chosen option will depend on the type of feed commodity to be stored. Storage options include silos, covered flat bottom storage bays and tanks for liquid feedstuffs.

Most dry feed commodities are available in loose (e.g. meal, shreds or cake) or pelleted forms. All require closed, or covered, structures to keep out rain.

Wet feed commodities are typically available in a loose shred, or meal, form. Some, such as brewer grains and citrus pulp shreds, are now available partially dried or dewatered (e.g. squeezed/pressed) to reduce freight costs and enhance handling and storage characteristics.

Silos allow gravity unloading of stored feed commodities such as grain, but liquid feedstuffs will need tank storage. These storage structures are discussed further in *Section 30 – Grain storage and handling* and *Section 34 – Liquid feeds*.

Flat-bottom storages are usually concrete bottom bays with wooden (e.g. timber sleepers), steel or concrete (e.g. pre-cast or cast in-situ) walls. Without a concrete floor, feed can be contaminated with stones and dirt. Front end, or telescopic, loaders used to load the feed truck or mixer need direct access for fast and efficient operation.

Several storage bays may be located next to each other in a special open-sided or open-ended covered building that is often referred to as a commodity shed. Bays may also be incorporated in other on site buildings.

Commodity sheds usually incorporate multiple feed commodity storage bays. The number of bays will depend on the number of different ingredients, or commodities, likely to be used in the ration mixes. Large bays allow for the purchase of large quantities of bulk feed commodities. Extra bays can minimise waste and spoilage by allowing each bay to be emptied before taking delivery of another load, while also allowing extra stored feed commodities for emergencies.

Flat storage commodity sheds are especially useful for by-product ingredients that do not flow, cannot be moved with augers or cannot be stored in conventional silos where gravity flow is required. An example is brewer grains, which may have inconsistent and unpredictable handling characteristics.

Layout

Factors that affect the design and layout of a flat bottom storage system include

- Size and type of vehicles that will deliver materials and method of unloading.
- Size and type of vehicles that will access the bay for filling or retrieving feed commodities.



Storage structures for dry feed commodities should be closed or covered to protect the contents from the weather.



Any storage facility may be adapted to store feed commodities. The side wall from this machinery shed has been removed and storage bays constructed.



A purpose-built, stand-alone commodity storage shed. The high roof allows direct loading of storage bays from a tipping-trailer truck. A large concrete apron in the front of the bays allows easy vehicle manoeuvring.



Filling commodity bays by loader can be time consuming and can interrupt loading of feed trucks.



A cross conveyor can transfer grain into one or more bays. Highly visible bollards protect structural members and walls from damage by machinery.



Concrete placed around structural members offers little protection, as the impact is transferred directly to the steel member.

- Preferred location for loading the feed truck or mixer.
- Location and layout of grain processing and handling equipment – extra bay or bays for processed grain.
- The number and amount of ingredients to be stored.
- Filling and retrieving preference – drive in, reverse out or push-through.

Flat bottom storage configurations include

- Open-front buildings with a single row of separate storage bays – with push-through bays or closed end bays.
- Enclosed buildings with two rows of separate storage bays and a central aisle – with push-through bays or closed end bays.

Flat bottom storage commodity sheds are typically concrete base bays with timber, steel or concrete side walls. Front end or articulated loaders are generally used for both loading and unloading feed from the storage bays to the feed truck or mixer and need convenient access. For single-row, open-front buildings, a concrete apron in front of the bays allows manoeuvring by delivery vehicles and equipment.

The next delivery can be placed in extra bays so that older material does not become buried in the back of a closed storage bay with drive in, reverse out systems. Alternatively, a push-through bay design may be used.

Where possible, the bays should be designed and located to allow the delivery vehicle to unload the material directly into the appropriate bay to minimise double handling.

A high roof clearance and ability to back straight into the bay is needed if feed commodities are unloaded from tipping trailers directly into the bay. Many commodity sheds have a steep monoslope roof with ample open space in front.

Other unloading techniques include a walking floor in the delivery trailer and hopper-bottom type trailers, which need direct access to the bays but require less height clearance.

An alternative strategy is to unload the truck on to a large paved area in front of the storage bays and then push the feed into the bay with a front end loader. However, as material will spread out as it falls from the delivery vehicle, the clean paved area must be large enough to prevent contamination with adjacent feed commodities, dirt or debris.

This method can be used to reduce the clearance needed for both manoeuvring and unloading and may allow material to be piled higher in the bay.

Construction techniques can also vary. Pre-cast or poured-in-place concrete walls can be used and then a roof built on top of the walls. Alternatively, a post frame building can be built and the bays constructed on the base as independent structures.

Whatever the roof design or wall type, the bays must be able to withstand the load of the product and the loads caused by vehicles pushing into the walls.

Reinforced concrete walls are expensive, but provide the best protection and will also better withstand corner blows with loader buckets or truck tailgates. These walls and any exposed shed supports can be protected from damage by strong concrete filled steel bollards.

Commodity sheds are often used to store other items, such as machinery and/or fertiliser. If this is a planned management practice, additional room and bays will need to be designed into the system.

Hay processing equipment may be sited adjacent to the commodity shed (see Section 33 – Hay storage and processing).

Figure 1 provides an example of a large commodity shed layout with push-through bays on one side, closed-end bays on the other side and a batch box loadout. Bays can be configured to various widths depending on the storage volume required. A cross section through the commodity shed is shown in Figure 2. The roof line is angled to accommodate tipping trailers.



Differing heights between the commodity storage area and the feed vehicle loading bay allow ease of operation and safety.

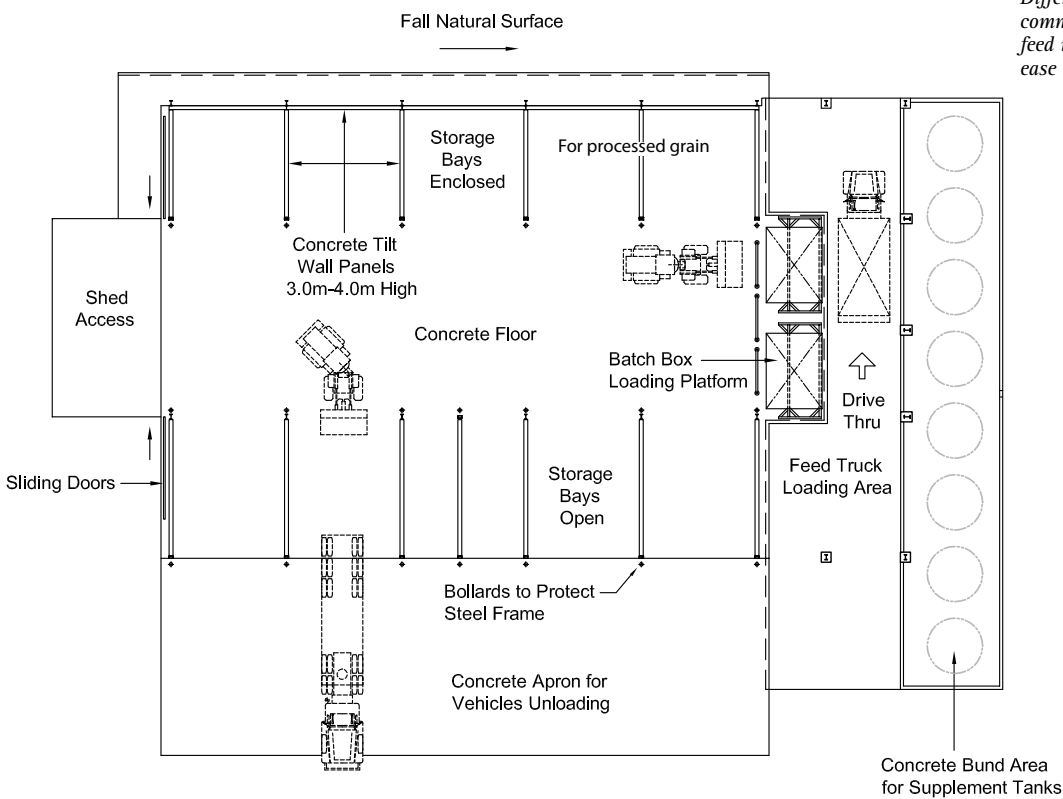

Figure 1. Example of large commodity shed plan view (with batch boxes)

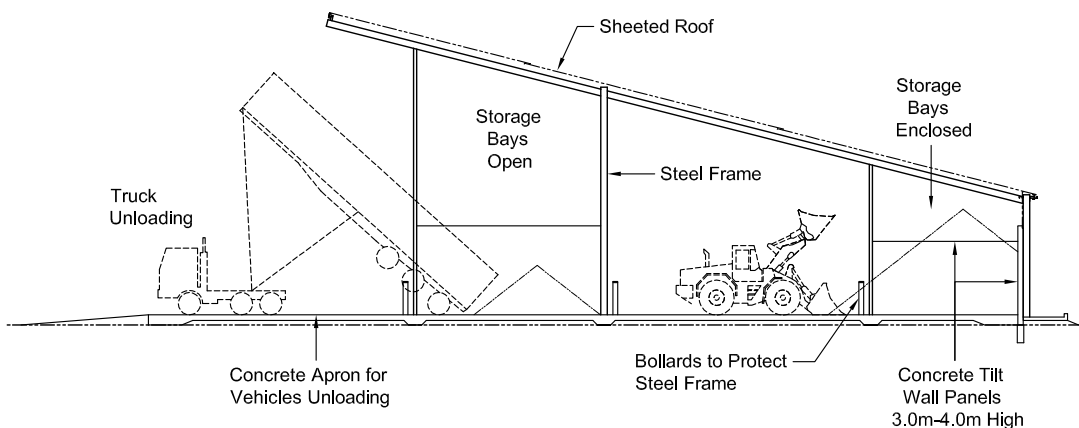

Figure 2. Cross section through commodity shed (Figure 1).

Figure 3 provides an example of a medium sized commodity shed layout with push-through bays on one side, closed end bays on the other side and a batch box loadout. The shed has a pitched roof and an external truck unloading area. This design requires the front end loader to push the unloaded feed commodities into the storage bays. A cross section through the commodity shed is shown in Figure 4.

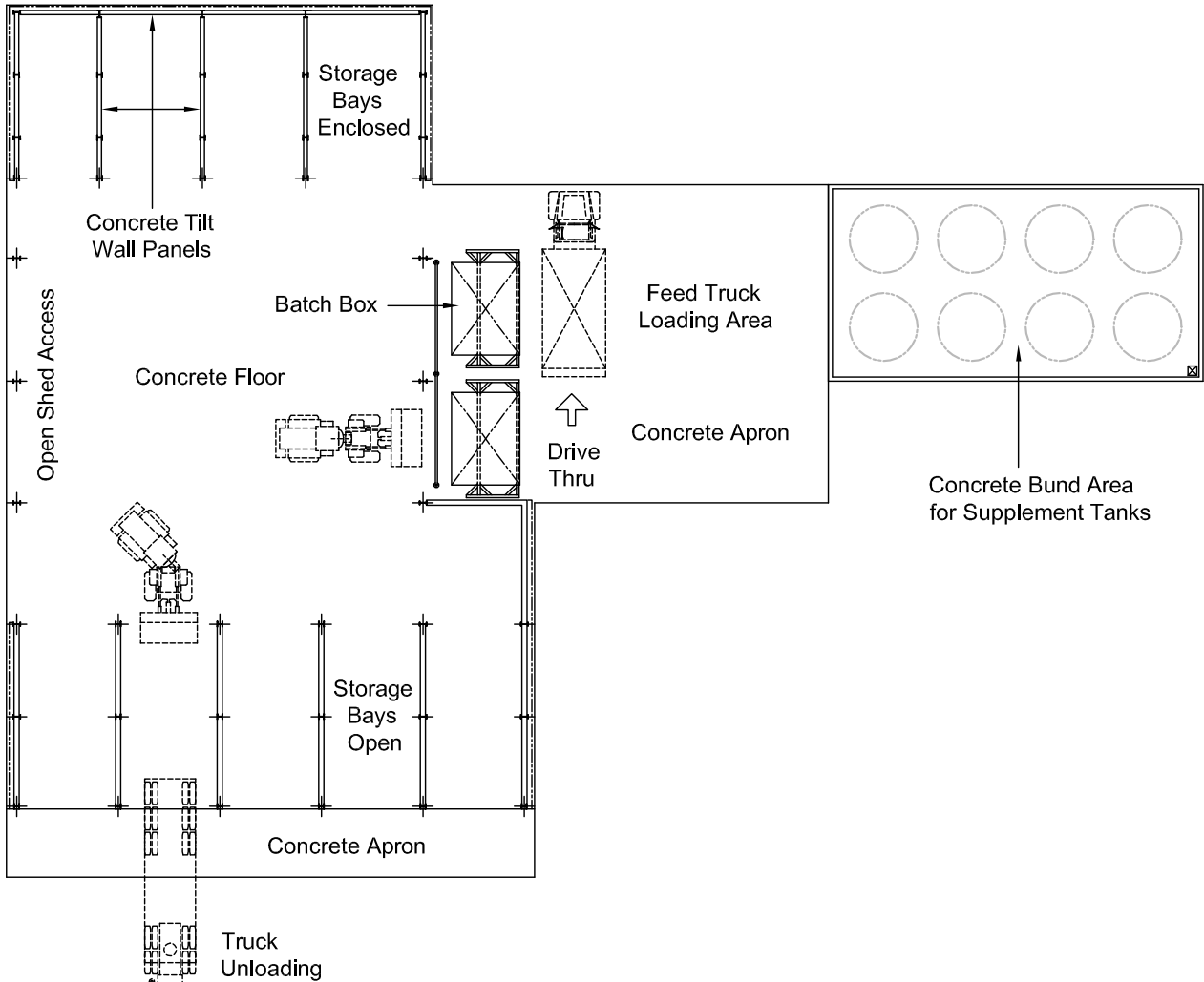

Figure 3. Example of a medium-sized commodity shed plan view (with batch boxes).

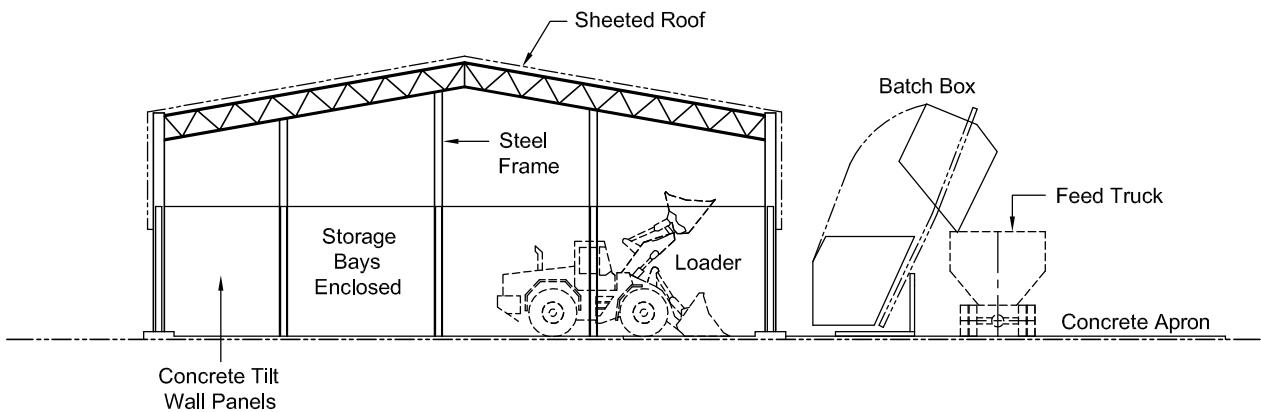

Figure 4. Cross section through medium-sized commodity shed (Figure 3)

Figure 5 shows an example of a small-sized commodity shed layout with one row of enclosed bays, a sloped roof and external loading area. A cross section through the commodity shed is shown in Figure 6.

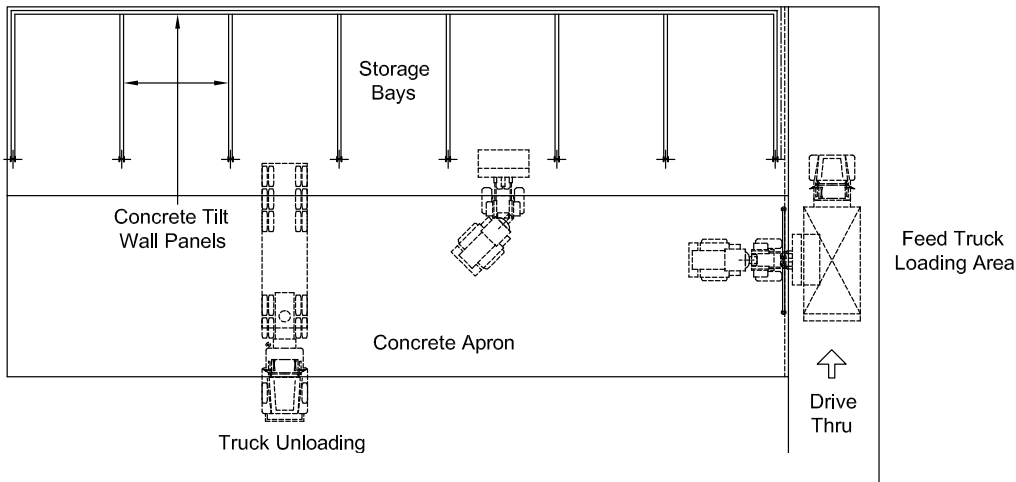

Figure 5. Example of single row open-side commodity shed plan view

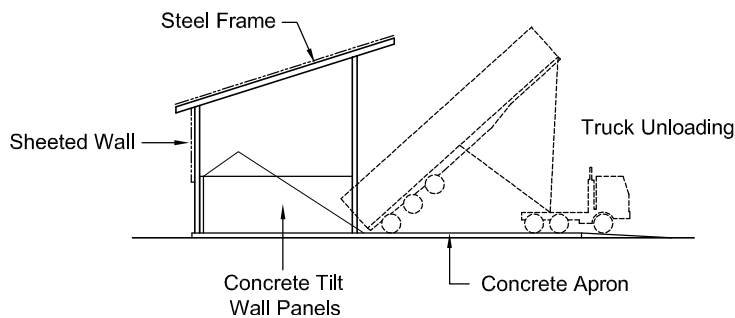

Figure 6. Cross section through single row open-side commodity shed (Figure 5).

Size

The size of the commodity storage facility will depend on the number and volume of feed commodities to be stored.

The total volume required can be calculated as the amount of space occupied by the feed commodity for the amount of time required to use the feed commodity. Feed commodity usage rates should match the acceptable shelf life window of each commodity.

The amount of storage needed for a particular feed commodity will be a multiple of the unit truck capacity plus a cushion of 25–50%, depending on the purchasing and transportation arrangements and whether replacement material will be unloaded in the same bin that is being fed out.

A semi-trailer has a capacity of about 24t. For dense products, such as cottonseed meal, soybean meal and pelleted ingredients, one truck load will almost equal the semi-trailer weight capacity.



Length and width of individual bays and height of divider walls should be designed to match the volume of material to be stored. Grains with a flatter angle of repose will form flatter piles.



Large push-through bays allow fresh material to be accessible over time.

For less dense products, such as brans, hulls, brewers and distiller grain, truck volume is the limiting factor. The equivalent load size will contain about 20–22t of material. For maximum flexibility, the bay should be designed to hold the maximum truck load capacity that is expected to be received in a single delivery.

Once the volume is known, the size of the storage bay can be determined. In addition to holding the appropriate volume and weight of material, it must be sized and located to accommodate delivery vehicles with a minimum width to allow easy loading and unloading of the bays. This is usually determined by the size of the vehicles to be used (e.g. front end loader). Clearance will be needed alongside the delivery trucks to safely open tailgates or end doors.

If material is to be pushed up with a loader, the maximum depth is limited by the reach of the loader and the skill of the loader operator. Reinforced walls will need to be higher and strong enough to support the additional loads imposed by the loader and the deeper pile of material.

Most operators find it convenient to have more bays than the number of feed commodities that are fed. Two additional bays are generally sufficient. This allows room for storing a pre-mix, an extra load of a feed commodity at a good price, a reserve in case of plant or road closures or taking fresh load while using the remainder of an older load.

The base of the bays and any concrete apron should be sloped away from the storage bay to prevent water flowing into the bay.

The orientation of the commodity shed should ensure adequate protection against the prevailing wind so that commodities are not exposed to blowing rainfall during storms.

Supplement storage

The quantities of dry supplement ingredients, such as enzymes, minerals, urea and salts, may not be large enough for bulk storage. However, they may still constitute a considerable number of bags/bulk bags/pallets that need to be stored out of the weather and close to the commodity shed. A common solution is to use one bay of a commodity shed, or a small shed with a gravel floor, for items on pallets.



The volume of individual bays should be designed to cater for the volume of delivery vehicles so that all material can be stored under cover.

Quick tips

- A commodity storage facility should be situated so all feed commodity and delivery vehicles, from both on and off the feedlot, are contained in a designated area and adequate room is available for any future expansion.
- Provide sufficient room to deliver feedstuffs into the commodity storage facility without interfering with the daily feeding process.
- A one-way traffic flow, with vehicles primarily moving in a similar direction, is best.
- Allow adequate room for expansion and flexibility in the commodity storage facility design.
- The physical characteristics of a feed commodity (e.g. bulk density, angle of repose and particle dimensions) will affect the storage space and design.
- Concreting the floor of a flat-bottomed storage facility will prevent feed being contaminated with dirt or stones.
- Storage bays can be constructed with pre-cast concrete walls, cast in-situ concrete, timber sleepers or large concrete blocks. Allow adequate room for manoeuvring front end loaders between mirrored bays and have a concrete area in front of the bays for truck unloading.
- Provide extra bays, or use a push-through design, to prevent older feed material being buried in the back of a storage bay.

Further reading

ASAE, 1987, ASAED241.3.1987, Density, specific gravity and weight moisture relationships of grain for storage. ASAE Standards 1987. pp 298-305.

Appel, W.B., 1985. Physical Properties of Feed Ingredients. Feed Manufacturing Technology III. pp 557-562 American Feed Industry Association. Arlington VA.

Bath, D.L., Dunbar, J.R., King, J.M., Berry, S.L., Leonard, R.O. and S. Olbrich, S.E. 1990. Byproducts and unusual feedstuffs. Feedstuffs Reference Issue. Feedstuffs 62 (3 1):32-37.

Australian Building Codes Board (ABCB), 2013, Volumes One and Two of the National Construction Code of Australia.

Kammel, D.W. 1991. Physical Characteristics of Alternative Feeds. University of Wisconsin-Madison.

Prevatt, W. and Prevatt, C., Commodity Feed Barn Storage: Is It Profitable For Me? Auburn University, Alabama Cooperative Extension Series.

Tyson, J.T. and Graves, R.E., Bulk Storage Agricultural & Biological Engineering Extension, Penn State University

Williams, D.L, 1991, Handling and Storage of Alternative Feeds. University of Wisconsin-Madison.

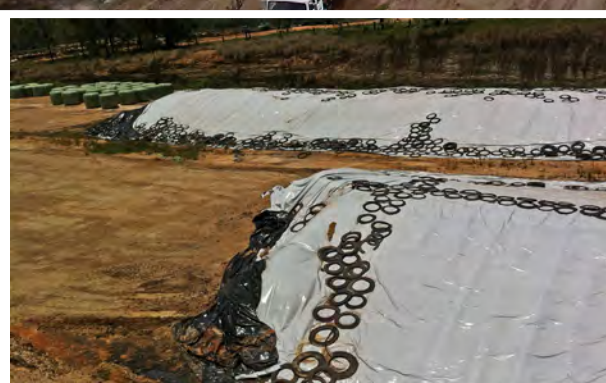

FEEDLOT DESIGN AND CONSTRUCTION

32. Silage storage

AUTHOR: Rod Davis

Introduction

Silage is forage (e.g. pastures, cereals or legumes) cut at high moisture content (typically 40–70%) and stored in an oxygen free (anaerobic) environment. Anaerobic storage promotes fermentation and the production of lactic acid. A pH of 4.0–4.5 preserves the forage.

Poorly fermented silage has lower nutrient value and palatability and produces unpleasant odours. Critical processes for good quality silage include

- Timing of harvest (stage of forage maturity, moisture content).
- Harvesting method (inoculants, grain conditioning, chop length).
- Filling, packing and sealing of silage storage system.
- Storage system management.

Design objectives

Silage storage systems should be designed and constructed to

- Be located in the controlled drainage area (CDA) of the feedlot and near the feed processing and preparation area.
- Provide sufficient slope to allow rainfall and silage effluent to drain away from the storage site.
- Be structurally sound and long lasting.
- Provide safe access for people and machinery during filling and removal.
- Provide an airtight storage system as quickly as possible after harvesting and ensiling.
- Maintain an airtight seal until feeding out starts.
- Provide sufficient storage capacity for expected feedlot demand, considering seasonal and regional availability and ability to maintain silage quality during storage.
- Promote sound economic inventory control.

Mandatory requirements

Design choices

Silage characteristics

Optimum dry matter (DM) content for ensiling. Table 1 indicates recommended DM content ranges for a variety of crops/pastures for either bunker or bale silage storage.

Table 1. Recommended dry matter content ranges for bunker, stack and bale silage (Kaiser et al. 2003)

Crop type (growth stage when to cut)	Bunker/stack (DM%)	Bale* (DM%)
Pastures (vegetative to very early heading)		
– long chopped	30–35	40–50
– precision chopped	35–40	
Lucerne (bud less than 10% flowered)		
– long chopped	33–35	40–50
– precision chopped	33–45	
Other pasture (early to mid-flowering)		
– long chopped	33–35	40–50
– precision chopped	35–45	
Whole crop cereals (vegetative stage) – oats, barley, wheat, triticale		
– flag leaf to boot stage	33–40	38–50
Whole crop cereals (direct harvested) – barley, wheat, triticale		
– late milk to soft dough stage	33–40	38–50
Maize		
– precision chopped	33–36	
Summer forages – sweet sorghum, millet		
– long chopped	30–35	35–45
– precision chopped	30–40	
Brassicac	33–35	38–45

* Large rectangular bales could be increased by 5-10% DM. If too dry, fermentation may not occur and it greatly increases the risk to moulding if plastic seal is punctured.

Density – As silage densities are highly variable, storage and feed budgeting calculations should be based on on site measurements. Typical densities for wilted pastures and maize are 590kg/m³ and 690kg/m³, respectively. Bulk density increases with the depth of silage in the bunker or stack. Table 2 shows typical values for DM, wet and dry density and particle size for hay and maize silage over a large range of bunkers.

Table 2. Dry matter content and densities from hay and maize silage (Kaiser et al 2003)

Characteristic	* Hay crop silage		** Maize silage	
	Average	Range	Average	Range
DM content (%)	42	24–67	34	25–46
Wet density (kg/m ³)	590	210–980	690	370–960
DM density (kg/m ³)	237	106–434	232	125–378
Average particle size (mm)	11.7	6.9–31.2	10.9	7.1–17.3

* Data based on 87 bunkers/stacks from Wisconsin, United States, mainly lucerne.

** Data based on 81 bunkers/stacks from Wisconsin, United States.



An above ground stack with no side walls. Note stack lay out on compacted earthen pad.



Hillside pits excavated into the side of the slope. The natural slope provides adequate drainage for the open end of the pit.



A pit excavated into gently sloping site. Cut soil material has been used to raise height of the embankment, but contains rocks.

Storage systems

Silage can be stored above ground (horizontal or vertical), or in hillside pits (horizontal). The most common methods at a feedlot include hillside pits, above ground bunkers, in ground pits or trenches and stack and bale silage.

The system used will depend on cost, area available, topography, equipment available, expertise and personal preference.

Whatever the method used, the main functions are to exclude air during the ensiling process, prevent air from entering the silage during storage and minimise losses and quality problems during feeding out.

Modern technologies, such as inoculants, preservatives and oxygen-impermeable covers, can greatly reduce surface losses - irrespective of storage method.

Above ground stack (bun)

Silage stacks are for short term storage. The silage is placed on top of the ground, then compacted and covered. As there are no side walls, the height of the stack is limited and the surface area to volume ratio is higher. The greater surface area increases potential spoilage.

Stacks should be located in an area with a slight slope for drainage and away from trees to minimise potential damage from falling limbs and birds. The stack width should fit the size of the plastic cover to be used. For example, a plastic cover of 13 x 33m will allow a pile width of 9–10m to be sealed by burying, or overlapping, the edges of the sheet.

Advantages

- No material construction costs.
- Easily sealed using a grader blade or front end loader bucket.
- Removing silage from the face minimises loose silage, reducing air penetration into the bun.
- Size of bun can be adjusted to suit rate of feeding.
- Multiple separate buns can promote quality and better inventory control.

Disadvantages

- High surface area to volume ratio, thus larger area to cover and greater chance of surface spoilage.
- Can be a workplace health and safety issue for tractor operators during stack formation and compaction.
- Not suitable for long term storage, unless the cover is protected from sunlight exposure (UV degradation).

Hillside pits

Hillside pits are usually dug into the sides or tops of hills, or high embankments, with the 'down hill' end open for drainage and pit access. The surrounding earth provides the side walls of the storage. Earth walls should be sloped to prevent caving in and to enable adequate silage packing. Where soil is unstable, the walls may need to be lined with concrete or untreated timber.

A convenient width for unloading with a tractor and front end loader is 7m (small feedlot) to 15m (large feedlot).

Advantages

- Suitable for long and short term storage.
- Lower risk of water entry compared to in ground pits.
- Reduced area to cover compared to above ground storage with no walls.
- Can be replicated by sharing a common wall on either side.

Disadvantages

- Earth walls may become unstable if rocks or loose soil are encountered.
- Location must be planned to avoid problems with water run-off.
- Direct contact with soil generates risks of clostridia and mycotoxins.
- During unloading, any rocks picked up will damage feed mixing equipment.

Bunker storage

Bunker storages are permanent structures constructed above ground and are commonly used in flat areas. Above ground walls are constructed using concrete, earth, steel or timber and braced with timber or concrete buttresses.

Timber contacting silage should not be treated with preservatives and silage acids will corrode concrete or steel over time. Round bales lined with plastic have also been used for bunker storage walls, but this is typically a temporary solution.

Bunker storages are rectangular in shape and are open at one or both ends. Most have earth floors, but concrete flooring provides all weather access. Bunker storages must have adequate drainage.

The height and width of the structure will depend on the daily silage usage, based on the removal of the required amount of silage per day from the silage face. Generally, about 0.3-0.5m depth of silage needs to be removed from the face each time and the full face of the pit should be traversed every one or two days to minimise spoilage in the exposed face.

The height of the silage in the pit should not be higher than the extended bucket of the front end loader removing the silage in case the loader overturns, or gets buried if the silage face collapses.

Advantages

- Can be built in areas where the soil type is rocky or has a high water table.
- Is reasonably inexpensive to construct (with earth floors).
- Can be replicated by sharing a common wall on either side.

Disadvantages

- Concrete floor bunkers are expensive to construct.
- Poor compaction, or an uneven surface, can lead to water pooling where the cover meets the side walls.
- Earth walls must have stable slopes.
- Requires regular maintenance (e.g. cleaning walls, weed control and re-surfacing the base).
- Losses or wastage from silage can be caught on walls.



An above ground bunker stack with vertical concrete walls and end wall.



An above ground bunker storage with pre-cast concrete panels laid against the earth embankment. These bunkers are located next to the commodity shed for easy access.

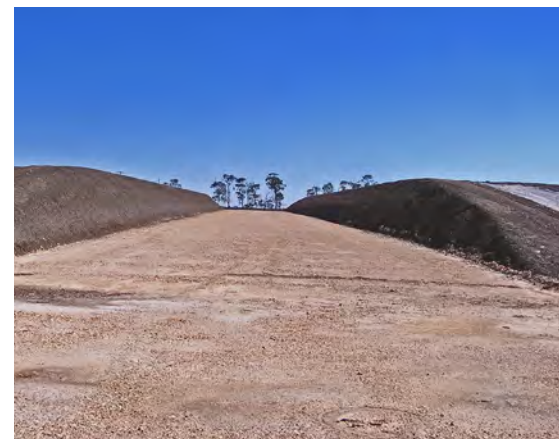

Above ground bunker storage with gravel base and compacted clay walls. The embankments are graded to the end of the storage and the top centres are overlaid with plastic to reduce erosion from stormwater run-off.



A hillside pit with near vertical walls and covered with soil. The soil type here provides a stable and durable side wall – which may not always be the case.



Open-ended, above ground bunker with compacted gravel base and clay walls. The walls are trimmed to the design batter and base to the design grade. A flat sloping end face allows water to drain from top of wall to ground level without eroding the face.

Stretchable bag/bale storage

Stretchable bag/bale storage systems are typically temporary and used for making haylage (wilted forage that is stored at higher dry matter, see Table 1). The forage is compacted, as it is forced into a plastic cover, bag, wrap or tube which is then sealed to exclude oxygen to assist the fermentation process.

These heavyweight plastic bags are available in various diameters and lengths and offer a range of storage capacities.

Advantages

- Greatest flexibility with the storage location.
- Low capital requirement.
- Low labour requirement.
- Stronger wrapping achieved, as the bales can be wrapped multiple times.
- Relatively small face is exposed when a bale(s) is retrieved, which reduces aerobic spoilage.

Disadvantages

- Specialised wrapping machine is required.
- Spoilage can be large if care is not taken to adequately seal out oxygen during the wrapping process and during storage.
- Not suitable for long term storage, unless the cover is protected from sunlight exposure (UV degradation) and predator damage.
- Disposal of used plastic may present problems.
- Preparation costs are high due to the cost of the plastic required to seal the forage.

Location on site

At feedlots, most silage storage facilities are permanently located. General site considerations are discussed in *Section 2 – Feedlot site layout* and *Section 28 – Feed preparation and storage*. Additional factors are outlined below.

Accessibility

The storage site is usually located close to the feed processing facility/commodity shed to minimise the distance and time to travel to and from the site during feeding out.

Sufficient space, with appropriate truck turn arounds, is needed to unload delivery trucks and to transfer silage to the feed processing area.

Above or below ground constraints

Sites with above or below ground constraints should be avoided. For example, overhead powerlines pose a hazard to machinery during placement of forage and feedout. Falling limbs and bird damage to the plastic covers may be more prevalent near trees.

Topography and drainage

For bunker storages, sites with a uniform natural slope of about 2% will help to minimise the cost of earthworks, as this will direct leachate to the drainage system of the controlled drainage area.

Sites with a low gradient can be more difficult (and expensive) to design and install adequate drainage.

Stormwater run-off should be diverted away from silage storage structures. A cut-off trench should be dug around any free standing stack to collect and divert water.

Geotechnical

The physical properties of the soil at the site should be assessed to determine the suitability of the material for base and embankment construction. Further information about material suitability for protection of groundwater and trafficability can be found in *Section 17 - Pen and road surfaces* and *Section 12 - Holding pond design*. Correctly compacted clay soils (and concrete floors) can limit leachate seepage.

There should be a sufficient depth of soil to accommodate excavation (cut and fill and borrowing) requirements if any storage embankments are needed.

Groundwater protection

Storage facilities should be situated to prevent contamination of groundwater by silage leachate.

Surface water protection and flooding

Storage facilities should be situated so that silage leachate poses no risk to surface water quality and riverine ecosystems. Silage leachate contains water soluble carbohydrates, proteins, minerals and fermentation products (i.e. nutrients) and can yield a high biological oxygen demand (in the order of 12,000–83,000mg/L). The quantity of leachate produced is a function of the dry matter content of the forage ensiled, particle size of chop and the extent of compaction.

Construction

Correctly constructed storage facilities will allow better compression and sealing of silage, significantly improving quality, reducing wastage and improving storage life, while having low maintenance costs.

Materials

Various materials and construction techniques can be used to construct silage storage facilities.

Common materials for construction of side walls include concrete (pre-formed or fabricated on site), timber (e.g. railway sleepers) and earth embankments. The wall is usually reinforced, or supported by posts (e.g. steel or timber) or earth. Silage leachate is extremely corrosive and can damage concrete and steel. Adding silicon or silicate to concrete can help to protect against acidity and pitting. Asphalt may be more corrosion resistant than concrete.

The floor or base of pits and bunkers is usually compacted soil or gravel. A concrete floor reduces contamination from air and soil and reduces wastage when feeding out—but is also the most expensive option. The floor should be impermeable to prevent leachate from contaminating groundwater and should extend out beyond the bunker walls.

The gravel pavement should have a thickness of 200–300mm to support typical vehicle loadings (e.g. semi-trailer, telescopic/front end loaders) and facilitate access after wet weather.



Hillside pit with near vertical walls. Side walls that are too steep may collapse on impact of machinery, or from erosion when empty.



Rocks and tree roots in this earth bunker wall could contaminate silage and damage plastic covers.

The walls and floor of a bunker storage must be able to withstand the pressure of the compacted silage and impact of machinery during placement and feedout. A durable all-weather surface can withstand heavy point loadings and the impacts of machinery dry-steering, as well as resist corrosion from leachate.

Concrete floors need to be laid properly to ensure liquid cannot pass through - with expansion joints sealed with a flexible compound. A concrete floor should be 125–150mm thick and reinforced by 32MPa concrete to support the size and type of vehicles used and for durability.

Wall geometry

Sloping bunker walls, rather than vertical, allow more efficient compaction of forage at the edges and will increase compaction with depth.

Earth walls must be stable under all conditions of construction and operation. Some natural slopes with marginal stability can fail with relatively minor works, such as excavation or removal of vegetation.

The top and end face of earth walls should be capped by gravel to about 150mm to minimise erosion.

The chosen slope ratio will depend on the following

- Soil types and strength parameters.
- Soil layering – changes in geology of the site (e.g. soft layers).
- External loads – roads.
- Construction – the construction technique, schedule and any safety issues.
- Erosion control – particularly where sand, non-plastic silt and dispersive clays are used as embankment fill materials or found in cut slopes.

Earth walls may collapse or subside if the slope is too steep. Slope stability analysis should be carried out by a qualified and experienced geotechnical engineer.

Earth walls should be compacted using suitable soils and the wall slope (batter) cut from the compacted earthen embankment.

Most pre-cast concrete bunker walls are tapered with the bottom wider than the top for strength. Concrete walls should be reinforced according to Australian Standard AS3600–Concrete Structures and erected according to AS3850- 2003 Tilt-up concrete construction.

Table 3 provides typical floor (base) and wall construction slopes for earth, gravel and concrete silage storages. A steeper floor is required for earth floor storages to ensure leachate drains.

Table 3. Typical floor and wall construction slopes for silage storages

Floor type	Suggested slope (horizontal to vertical)
Earth floor	50:1 (2%)
Gravel/Concrete floor	100: 1 (1%)
Wall type	
Earth walls - compacted clay	1:1 (45°) – 1:2 (65°)
Concrete walls	1:1 (45°) – vertical

The top of walls should drain to the feedout face with end wall bunkers or to both directions with open bunkers. The top of the wall should be graded with an even longitudinal slope of 1% (gravel) to 2% (earth) to cater for run-off from the plastic cover. The end face of the bunker wall is a steep slope that can erode and will need to be protected from erosion that may be caused by the run-off.

End wall

Bunker storages may be constructed with or without an end wall.

Advantages of an end wall include

- The ability to construct the storage into a hill.
- Forage can be delivered from the closed end and the sides.
- The walls can be driven over when the bunker is filled at that level.

Disadvantages include

- Safety concerns when working near the top of walls (e.g. tipping into the empty bunker).
- Difficulties in lengthening the bunker, if desired.

Advantages of no end wall include

- Can be filled and/or unloaded from either end.
- Self-unloading wagons can be pulled through the structure if the bunker is filled with a single product in a short period of time.
- Bunker can be lengthened more easily.

However, water can accumulate at the feedout face as the floor slopes towards one feedout face.

Drainage

The floor of a bunker storage or stack should be constructed to a finished height of 200–300mm above the surrounding natural surface level to prevent extraneous stormwater entering the storage site. The floor should be sloped towards the feedout face and collection drain with a gradient of about 1:100 and no cross fall.

Capturing and diverting leachate away from the entrance to the storage will reduce the incidence of soil and/or mud being trafficked into the storage site and contaminating the silage. A narrow (0.3–0.5m) drain should be constructed along the full width of the storage site (downslope end) to capture and direct effluent into a catch drain.

Silage stacks on the ground also require a sealed surface, with leachate directed to a collection point and correctly contained. A shallow drain around the stack will help prevent water run-off from the pad entering the stack.

Run-off from the silage cover should be prevented from flowing between the silage and bunker walls by heaping the silage above the top of the wall and by ensuring the cover extends on to the side and end walls. Run-off is directed along the top of the wall and along its length. The silage pile should be sloped towards the feed-out face of the bunker so that water flows over the plastic and onto the ground. However, this may not be necessary if there is good side slope drainage.



A poorly drained bunker floor allows leachate to remain in the bunker area. The soft floor allows ruts from machinery – exacerbating the problem.

Geometry

Review aspects of both filling and inventory management before selecting the size and number of structures to construct.

Long, deep, narrow pits are preferred over short, wide, shallow storages because these are easier to fill and compact progressively and minimise exposure to air when feeding out.

The target removal rate should be to a depth of at least 0.15m/day, increasing to 0.30m/day for unstable silages, such as maize. Removing 0.15–0.30m/day minimises aerobic spoilage, as silage is removed from the bunker, or stack, and the complete face of the silage bunker should be traversed at this depth every one or two days.

To correctly size the storage

1. Determine the quantity of silage that will be fed from the pile each day (in kilograms).
2. Determine the cross-sectional area of the feed-out face or pile by dividing the quantity of silage that will be fed from the pile each day by the density of the silage (kg/m³) multiplied by the rate of removal (0.15m) and the number of days to transverse the face.
3. The surface area can then be used to determine a suitable width and height for the bunker or stack. For example, divide the cross sectional area by the average depth to obtain the average width.

Calculating the cross-sectional area of the feed-out face to be removed per day is outlined below.

$$\text{Area of feeding face (m}^2\text{)} = \frac{\text{Quantity of silage fed per day (kg fresh weight)}}{\text{Silage density (kg/m}^3\text{)} \times \text{Rate of removal (m/day)}}$$

For chopped silage, the bunker or stack must be at least 1.8 times the width of the machinery used to compact the silage to ensure the centre can be compacted.

Constructing several smaller pits rather than one large one can increase flexibility of silage storage, improve quality and promote good inventory control.

The design of above ground silage stacks is similar to that of bunker structures, but the depth of the silage mass is restricted. At heights above about 3m, the base needs to be extended or the bun made longer. Selection of bun shape determines the formula for calculating capacity. Typically, buns are constructed as rectangles or trapezoids. The approach for calculating capacity and dimensions for a rectangle is the same as for the bunker.

Sealing and covering

The compacted forage must be given an air-tight seal as soon as practicable after harvesting and this must remain airtight until the bunker or stack is opened. Poor sealing results in degraded silage (with mould, nutrient loss, heating and odour), increased loss and the potential development of poisonous microtoxins.

After compaction, the top of the silage should be shaped to shed water.



The top of this silage has been shaped to shed water. Whole and split tyres firmly hold the plastic cover along the length of the bunker. Note the drainage line along the top of the side wall.

Covering during bun/pit filling and compaction significantly reduces formation of a cap (a layer of degraded silage on the outside of bun/pit). Combination covers such as Silostop™ (an oxygen-impermeable film), protected by heavy UV-resistant shade cloth or plastic, are ideal for sealing silage and preventing oxygen penetration during ensiling and feedout.

Covers should be weighted down using tyres, tyre beads or sand bags, rather than soil that could contaminate the silage with clostridia bacteria and mycotoxins.

Forage in pits should be stacked higher than the sides and the cover should extend and be secured over the sides.

Old silage covers may be used to create 'sausages' containing dirt, sand or small gravel and these can be laid in overlapping rows along the edges of the cover and in rows across the surface of the cover.

Tyres are commonly used to hold down plastic tightly against the silage and are easier to handle. Tyre sidewalls are lighter and easier to handle than whole tyres and do not collect rain, insects, spiders, vermin or snakes. When an oxygen-impermeable film is not used, tyres need to be laid so they touch one another to seal the plastic to the silage and minimise air spaces.

Covers should be inspected regularly and any holes repaired using specifically designed tape. The edges of a bunker storage must be kept sealed, as shrinkage leaves a space along the walls.

Walls, floors and drainage channels of bunkers should be cleaned when the bunker is empty and any cracks, corrosion or other faults mended before refilling.

Safety

Signage should be used to alert people of the dangers of approaching the storage (e.g. steep earth walls that may collapse after silage removal, limited visibility of the machinery operator when stacking/compacting or removing silage and falling hay bales).

Safety rails along the tops of bunker back walls will reduce the risk of machinery wheels dropping off the edge when rolling silage.

Any excavation during construction of silage storages can create safety issues for the machinery operators and workers. Check with Workcover or the relevant State authority to ensure the proposed design, construction and management of the silage storage complies with State and Commonwealth regulations.

Packing silage too high in the pit can lead to a front end loader overturning or being buried when removing silage for day-to-day feeding.



Tyre sidewalls used randomly to hold down plastic do not hold water or harbour vermin.



Silage pits should be situated in the CDA so that leachate can be directed and retained in the effluent drainage system.

Quick tips

- A range of systems for storing silage have advantages and disadvantages - and wide ranging capital costs.
- Select the system based on cost, available area, topography, available equipment, volume of silage to be used, expertise and personal preference.
- Access (traffic flow, unload/feed-out) and site suitability (topography/drainage, soil type) are key site selection factors. Permanent structures are costly to relocate.
- Allow additional area for potential expansion.
- Floors of bunker storages or pits need to be graded and compacted for good drainage and constructed to minimise risk of silage leachate contaminating groundwater.
- Earth walls must be stable under all conditions of construction and operation. Seek professional advice from a suitably qualified geotechnical engineer to guarantee the structural integrity of the proposed design, especially those involving above ground concrete or earth walls.
- Long, deep, narrow pits are recommended compared to short, wide, shallow storages because they are easier to fill and compact progressively - and minimise exposure to air when feeding out.
- Determine the width of the bunker or pit by calculating the cross-sectional area of the feed-out face and design height of the pile.
- After filling and compaction, shape the top of the silage in a bunker to shed water after the silage has settled and been covered.
- Weigh down plastic covers over the top of the pile with tyres, tyre side walls or sand bags to seal the silage. Tyre sidewalls are lighter and easier to handle than whole tyres.
- Bury the edges of covers on stacks in the ground to ensure an air-tight seal.
- Slope the length of earth embankments to the open end of the bunker or pit to direct stormwater run-off away from the pile. Erosion control may be required where dispersive clays are used, as embankment fill materials or found in cut slopes.

Further reading

Dairy Australia Online Publications – Pastures, Forages and Crops Section

<http://www.dairyaustralia.com.au/Animals-feed-and-environment/Feeding-and-nutrition/Pastures-forages-and-crops.aspx> (accessed 10-10-2012)

Kaiser, A.G. et al. 2003, Successful Silage, New South Wales Department of Primary Industries, Orange, New South Wales, ISBN 0734715835.

Standards Australia, 2009, AS3600-Concrete Structures

Standards Australia 2003, AS3850- 2003 Tilt-up concrete construction

Successful Silage Manual – Appendix 9 discusses how to diagnose and rectify spoilage losses in forage harvested and baled silages

University of Wisconsin Extension Services provides several downloads (PDF and MS PowerPoint presentations) with information on harvesting and storing forages.

<http://www.uwex.edu/ces/crops/uwforage/storage.htm> (accessed 10-10-2012)



FEEDLOT DESIGN AND CONSTRUCTION

33. Hay storage and processing

AUTHOR: Rod Davis

Introduction

Good quality hay and straw are used in feedlot production, particularly when cattle are introduced to grain based rations. Poor quality hay may inhibit intake, or be rejected and sorted out by the animals

Hay should be processed to a fibre length of 50–100mm so it can be thoroughly mixed in the ration and allow accurate measurement of daily feed intake. Processing can occur during baling (pre-conditioned or pre-cut), or in a tub grinder before being loaded into a feed mixer.

Hay and straw are bulky commodities that require a significant area and weather proof storage to maintain desired feed quality.

Design objectives

The design objectives when storing hay are to

- Provide an all-weather, well drained and trafficable storage site that is near to the feed processing area.
- Maintain hay quality.
- Ensure the space provides for efficient and safe storage.
- Provide sufficient storage capacity for expected feedlot demand.
- Minimise the risk of fire.
- Provide a supply of pressurised water.

Mandatory requirements

Council development or planning approval may be needed, unless already addressed as part of the feedlot approval.

Building approval is sometimes needed for farm sheds, depending on local council requirements and the location and size of the shed. Consult your local council in the planning stage.

Design choices

Functional design for hay storage implies convenience of access, ease of handling, good site preparation and base material and appropriate building design/covering to prevent weather damage to the hay. Outlined below are the key elements that should be considered when designing a hay storage facility.

Site selection

Most hay storage facilities at feedlots are permanently set up. General site considerations are discussed in *Section 28 – Feed preparation and storage* and *Section 2 – Feedlot site layout*. The additional factors that should be considered when selecting a hay storage site are outlined below.

Accessibility

The storage site is usually located close to the feed processing facility/commodity shed, but at a sufficient distance to minimise damage to infrastructure if the hay spontaneously combusts or catches fire.

Sufficient space should be provided for vehicle manoeuvring and truck turning, unloading delivery trucks and transferring hay to the feed

processing area. *Section 13 – Access and internal roads* provides further information about turning areas for typical feedlot vehicles.

Topography and drainage

Rainwater from the surrounding area and roof (if covered) must be drained away. Uncovered hay storage areas should be formed as a series of corrugations, rather than as a single plane, with a drainage path between each pair of corrugations. Each corrugation should be large enough to accommodate at least two rows of hay stacks (large square or round bales) and have a uniform cross fall of about 1% towards the drainage line.

Hay stacks should be aligned parallel with the longitudinal slope, with the corrugated cross-section allowing water to quickly drain away from each stack (rather than down a plane across multiple stacks).

The storage floor should be crowned about 200–300mm above the surrounding ground level. The storage area should have a longitudinal fall of 0.3–0.5%.

Building separation and expansion

Hay storage should be located near the feed processing area for efficient transport. However, as hay can occasionally catch fire (self-combust), there should be a space of at least 15m between hay storage and other buildings. This is a compromise between safety and efficiency.

Pressurised water hydrants next to hay storage areas will provide some control in case of fire.

Additional space should be allowed for future expansion if required.

Overhead powerlines

Sites near overhead powerlines should be avoided to remove any safety risk with machinery associated with hay stacking and unloading (e.g. telescopic loaders).

Storage types

Hay storages can include

- Buildings – options for permanent hay storage structures include steel sheds with an iron roof and exposed sides, or iron roof with three enclosed sides. End bales stored in open-ended buildings can be covered with tarps or cloth, or doors installed to prevent bleaching.
- Semi-permanent covers – these include plastic panels or reusable heavy duty tarpaulins that cover the top bales in the stack, or tarpaulins that are stretched over a steel frame. These covers should be treated to avoid photo-degradation by UV light and should have some means of distributing the strain of tie-downs across the length of the stack. The tarpaulins are usually made from polyethylene or polypropylene, and should last five to seven years.
- Uncovered pads – bales stacked on the ground with no cover are the cheapest method of hay storage, but have the highest potential of weathering loss. Much of this loss occurs on the bottom of the bale where moisture levels remain highest and air movement is lowest. Outside storage losses can be reduced by selecting a well



Fire hydrant located near the hay storage area.

drained site and placing coarse gravel or materials such as timber to break the contact with the damp soil and provide air space between the bottom of the bale and the soil surface.

Table 1. Advantages and disadvantages of various types of hay storage

	Solid roof	Semi-permanent roof	Uncovered
Advantages	Lowest dry matter losses (5–10%), higher nutritional value, digestibility and palatability. Shed has other potential uses (other than hay storage).	Lower dry matter losses than uncovered stacks. Tarpaulins are relocatable, quick to install, multi-purpose cover or liner.	Simple, low capital cost
Disadvantages	Fixed, hay has to be transported to and from the shed. High capital cost.	Wind can affect security of the cover. Rainfall can collect on the cover UV exposure and birds can decrease life span.	Highest dry matter losses (30–60%) Greater losses from round bales (loss increases with smaller bale diameter) Regions with higher rainfall and humidity have higher rates of hay spoilage and/or dry matter losses.
Life span	20+ years	2–10 years (depending on the use of UV stabilisers)	Highly variable depending on the climate and site preparation/maintenance

Storage capacity

Hay is often available once each year (typically at grain harvest), so storage volume may need to be large enough to last for a whole year.

The amount of hay storage needed depends on the quantity to be fed, the timing of hay being economically or seasonally purchased, storage type, space available for storage and bale type and size. Hay stored undercover can maintain its quality for more than 12 months, but hay stored outdoors without cover will show significant reductions in quality, dry matter and nutrients over time. Hay can typically be stored outdoors and uncovered for up to three months, with a maximum of six months.

Hay bales typically have a density of about 160–190kg/m³, but high density bales can be up to about 240–280kg/m³. Rectangular bales have higher bulk density than round bales. Denser bales create a more stable stack and will shed more rainwater if stored uncovered.

Stacks of rectangular bales require less space and so, by volume and mass, are cheaper to transport and stack in a covered storage system.

Building dimensions should be based on multiples of the size of bales to be stored plus 500mm at each outside wall. Many designs accommodate three layers of bales.

Adequate clearance to the bottom of the roof trusses, or other structural members, will allow for tilting of hay handling equipment (e.g. fully loaded front end loader). For most applications, this requires a minimum roof truss height of about 5.4m and 0.6m clearance between the top of the stack and the roof line.

Building design

Hay storage areas can be ‘partially enclosed’ or ‘roof only’ structures.

Partially enclosed structures are usually open at one end, or side, for ease of filling, but are otherwise totally enclosed. These offer full protection from weather (e.g. rain, sunlight and bleaching),



A steel framed, fixed roof open shed. Bales are more likely to be stacked on the stringed side to increase stack stability (as opposed to the unbraced side).

but are more expensive and may have more restrictive structural requirements than open walled buildings. These structures may also have poorer ventilation than roof only structures.

The building should be constructed square, true and level and have a weather tight roof. Structural needs are relatively simple, with the main requirement being ability to withstand wind loads. The wind force on side walls and the overturning wind forces are much greater for fully enclosed buildings than for similar buildings with open sides.

Many commercially manufactured rigid frame farm buildings will make excellent and economical hay storage areas. The wind loading should be appropriate for the locality and site and base preparation specified for the storage of hay.

Most shed companies provide a holistic design, structural design and manufacture service, but structural design requirements may be obtained from a consulting structural engineer. Further information about farm building construction techniques can be found in *Section 40 – Machinery workshops*.

Floor and base material

The floor of hay storage areas should be constructed to a finished height of 200–300mm above the surrounding natural surface level to prevent entry of stormwater run-off. Alternatively, shed walls and/or bunding can be used to exclude run-off. Water absorbed by bales at the bottom of the stack can not only cause spoilage, but also comprise the structural integrity of the stack and possibly result in the top bales tilting off.

The base material should maintain the quality of the baled hay and provide a durable all-weather surface that can withstand heavy point loadings (e.g. from fully loaded hay trucks and handling equipment) and the impacts of machinery dry-steering.

The best base for hay storage is a compacted granular material that provides good drainage. Larger rocks (up to cricket ball size), provide the best aeration and separation of the hay from damp earth or sub-base material. The gravel pavement should have a thickness of 200–300mm to support typical vehicle loadings and allow access after wet weather.

Condensation from concrete floors can cause spoilage but this may be prevented by spreading a layer of hay over the floor before placing the bales. Storing hay directly on an earth floor results in significant spoilage, with dry matter and nutrient losses.

Ventilation

Hay quality is compromised by moisture and poor air exchange. The storage must allow natural ventilation to remove moisture from several sources including

- Hay that is not completely dry.
- ‘Sweating’ due to respiration and microbial activity in the hay.
- Moisture that accumulates due to ‘moisture migration’ from warmer to cooler areas of a stack.
- Condensation that forms on the underside of steel roofs and drips on to the hay.



The large span of a steel framed, fixed roof open shed provides unrestricted access. Downpipes take roof water away from the storage area.



Fixed roof, open sheds vary in structural design and geometry.



Fixed solid roof, supported by concrete encased steel columns



Hay storage area – Bales are placed on a raised area with drainage lines on each side. Space between bales allows air flow and ventilation.



Semi-permanent PE tarpaulin with tie-downs attached to truck tyres. Stack size is based on transport load size.



Uncovered stack with round bales stacked in rows. Space between rows assists air flow and ventilation.

The open side of a three-sided shed, or covered stack, should face away from the prevailing wind to minimise weather exposure to stored hay and straw during storms and rain.

Adequate space between stacked bales improves ventilation and air flow.

Bale arrangement

Rectangular bales are best stacked in rows for ease of covering. Bales should be stacked so that each separate layer is stepped forward or back on the below bales to increase the stability of the stack.

When using semi-permanent covers, round bales can be stacked as high as is practical and safe (usually in a 3-2-1 pyramid design, with three bales in the bottom layer, two in the second layer and one on top). This arrangement minimises the size of the tarp needed relative to the volume of hay stored and forms a natural peak that will effectively shed water.

Falling hay bales, or the collapse of stacks, can cause injuries - and even potentially death - to personnel and damage to equipment. Stacks can become unstable if bales are stacked too high, the stack base is compacted or settles unevenly or the stack is exposed to weather.

A stable stack height should be determined before starting stacking, with regard to bale condition, terrain and equipment to be used.

For outdoor storage areas, a north-south orientation of stacks will increase the incidence of sun exposure on all exposed parts of the bales.

Round bales stored outdoors and uncovered are best stacked on their sides, end-to-end and in long rows orientated north-south to increase sun exposure to all exposed parts of the bales. Individual rows should be separated by at least 1m to promote drainage of rainfall and enhance air flow and ventilation that removes moisture expiring from the bales or ground surface.

If round bales are stored under cover, they can be stacked on their ends, several rows high and with each separate layer stepped forward or back on the below bales to increase stack stability. Alternatively, they can be stacked in rows on top of each other to form the 3-2-1 pyramid shape.

Another arrangement that does not require a loader attachment is a 3-2 pyramid. This lacks the natural peak that would more effectively shed water. Stacks of bales should be placed on a slope, running the direction of the length of the stack so that water would drain off the end of the tarp. This design reduces storage capacity by 17%, compared to the 3-2-1 stack, but requires a slightly smaller tarp.

Another alternative solution is to place square bales in the middle of the upper layer to construct a middle peak to the stack. The cost and trouble of the extra labour would have to be considered.

Bales should not be stacked against the side walls or end walls of buildings, as most sheds are not designed for the horizontal loads exerted by the bale stack.

Safe storage

Hay that has high moisture content when baled can heat up and spontaneously combust when stacked. Hay bales should be tested for internal moisture content before being placed in the storage area. Fire risk can be reduced by providing good ventilation (including leaving air space between rows of stacked bales) and by reducing the stack height, which lessens the mass loading on the bottom bales in the stack. Pressurised water hydrants would prevent fire spreading, but would be unlikely to extinguish a major fire.

Compliant mufflers/spark arrestors should be fitted to all hay handling and processing equipment and all machinery should be equipped with a portable fire extinguisher.

Signage should alert people to the dangers of approaching the hay storage area (e.g. bales falling from the stack and limited visibility of the machinery operator when stacking/unstacking hay).

Processing

Hay is processed to reduce the fibre length to 50–100mm. This allows good mixing with other ration ingredients and prevents animals separating out feed in the bunk. Feeding hay separately may result in a variable nutrient intake and production.

Processing methods are outlined below.

Pre-conditioning during baling

Bale conditioners cut hay into predetermined lengths during the baling process. Pre-conditioned bales are denser and this helps to reduce freight costs. Depending on cut lengths, pre-conditioning can eliminate the need for any further processing before feed out.

Tub grinding

Tub grinders use gravity and tub rotation to feed hay into a series of cutting knives, or a hammer mill at the base of the tub. The screen size of the hammer mill should be large to optimise fibre length without being too fine.

Hay hammer-milled or chopped hay is less dense at 100–150kg/m³.

Tub grinders quickly and effectively grind large volumes of hay, but have high power requirements. The speed at which a tub grinder is driven and the rate at which hay is fed into it can vary the fibre length. Typically, tub grinders are power take-off (PTO) driven by electric motors, tractors or diesel engines. These may be portable or permanently stationed.

Tub grinders should be located outside commodity sheds, as grinding can heat the material so that it can start smouldering, spontaneously combusting or catching fire. Fire fighting equipment should be provided and maintained next to the machine and a buffer allowed between other buildings and commodity storage areas.

Roughage can be thrown into the air above the tub and lost between the tub base and conveyor, or blown off the conveyor during unloading. Losses can be as high as 30% from dust and fine particles of hay. Dust may be a problem with tub grinding equipment. The direction of prevailing winds needs to be considered when locating permanently set equipment.



Diesel powered portable tub grinder. This model incorporates a dedicated power plant, but tractor-driven PTO systems are also available.



Electric powered semi-permanent tub grinder.



A permanently positioned electric powered tub grinder with the discharge conveyor set below ground level. This arrangement inside the commodity shed presents a greater fire hazard than a portable self contained unit that is easy to access and clean down.

Mixer processors

The most common type is the vertical mixer. These mixers can process and mix hay, eliminating the need for additional processing before feed out. These work best for mixing and feeding with low percentage hay rations and for small feedlots, where the overall quantity of rations fed out each day is low. For high percentage hay rations, cutting and mixing takes a long time and chop length may be inconsistent.

Quick tips

- Storing hay under cover preserves dry matter, nutrients and quality and may reduce shrinkage by 30%.
- Storing hay under cover reduces spoilage and contamination.
- By volume and mass, rectangular bales are more cost effective to transport and stack in a covered storage system.
- Exposed hay or shed openings should face away from the prevailing wind to minimise rain damage.
- Uncovered storage areas should be gravelled to accommodate vehicle loadings and all weather access.
- Uncovered or temporary storage areas should have a corrugated cross-section to help drainage.
- Orientate uncovered hay in rows running north-south to increase the bale exposure to the sun.
- Stacks of hay should be separated to increase air flow between bales, provide good ventilation and allow access for tying down tarpaulins.
- Tub grinders have high power requirements and increase shrinkage of hay during processing.
- Tub grinders can cause fires. Fire fighting equipment and proximity to buildings should be considered when setting up this machinery.

Further reading

Seirer, R. 1995, *Opportunity Lot Feeding of Beef Cattle*, Department of Primary Industries Victoria (DPIV) Agnote 0372, Melbourne, Victoria.

Polytex Tarpaulins

<http://www.polytex.net.au/> (Accessed 08-10-2012)

Dome Shelters

<http://www.awpgroup.net.au/products/domeshelter/agshelter.html>

Albert Agriculture and Rural Development 2001, *Hay Storage – Planning and Design Guidelines*, Alberta, Canada.

[http://www1.agric.gov.ab.ca/\\$department/deptdocs.nsf/all/eng2610#structure](http://www1.agric.gov.ab.ca/$department/deptdocs.nsf/all/eng2610#structure)

Hay Cap Covers

<http://www.haycap.com.au/index.html>

Darby, D. 2001, *Hay Storage – Planning and Design Guidelines*, Alberta Agriculture and Rural Development,

[http://www1.agric.gov.ab.ca/\\$department/deptdocs.nsf/all/eng2610#structure](http://www1.agric.gov.ab.ca/$department/deptdocs.nsf/all/eng2610#structure)



FEEDLOT DESIGN AND CONSTRUCTION

34. Liquid feedstuffs

AUTHOR: Rod Davis

Introduction

A feedlot ration combines several available feed ingredients to supply the nutritional needs of cattle in adequate amounts and in a cost effective way. Rations usually contain dry (e.g. grain, roughage), moist (e.g. silage, distiller grains) and liquid feedstuffs (e.g. molasses, vegetable oils, liquid supplements).

The most common liquid feedstuffs used in feedlot rations are molasses, vegetable oil, glycerol, solubles from fermentation (such as condensed distiller solubles), molasses-based vitamin and mineral supplements and water.

Liquid supplements can be either 'suspension' or 'solution' products. Suspension products use suspending agents to hold insoluble ingredients, such as limestone, in the supplement. Solution supplements contain highly soluble ingredients that stay dissolved.

Rates of inclusion of liquid feedstuffs depend on factors such as nutrient density, mixer characteristics, other ration ingredients and production requirements.

Design objectives

Liquid feed storage should be designed and constructed to

- Provide a functional space for storage of a range of liquid feeds.
- Provide separate storage areas for each liquid feed used.
- Provide sufficient storage capacity for a given volume of each liquid feed, considering seasonal supply and delivery patterns.
- Provide adequate storage to meet daily feeding requirements.
- Be close to the feed processing and preparation areas.
- Provide all-weather access and sufficient manoeuvrability for various types of delivery vehicles.
- Provide access from the ground for safe filling, emptying and cleaning.
- Minimise wastage and spoilage of liquid feeds.
- Protect groundwater, surface water quality and riverine ecosystems.
- Be able to effectively deliver liquids under cold conditions.

Mandatory requirements

The building elements, such as concrete footings, floor slabs and steel structures, shall achieve the structural provisions of the Building Code of Australia (BCA) and local building regulations and be designed in accordance with the relevant Australian standards.

Compliance with AS2865-2009 Confined Spaces for confined spaces entry requirements.

Design choices

Because of the variable nature and viscosity of liquid feedstuffs, tanks, pumps and other equipment need to be designed to handle specific products. Storage and handling requirements vary depending on the characteristics of the liquid feedstuffs. For example, molasses is commonly stored in flat-bottom vertical or horizontal tanks and suspension supplements are typically stored in cone-bottom vertical tanks. Heating may be required if vegetable oils contain saturated fat (e.g. palm oil), or for molasses use in colder areas. Insulation may be needed in hot locations.

The following factors should be considered before purchasing and installing liquid feedstuffs storage and handling equipment

- Type of liquid product to be handled (commercial supplement, molasses, vegetable oil or other by-product).
- Volume of liquid ingredients that will be handled.
- Ability to handle a full tanker load of product at each delivery.
- Quantity of product required on a daily basis.
- Feed delivery method.
- Cost of liquid feeds relative to other feeding options, such as dry supplements or other high moisture feeds.

Consideration must be given to where and how liquid ingredients will be added to the feed ration.

Site selection

General site considerations for liquid ingredient storage are discussed in *Section 28 – Feed preparation and storage* and *Section 2 – Feedlot site layout*.

Additional factors to be considered when selecting a site for liquid storage are outlined below.

Accessibility

The storage site should be located close to the point of addition to the feed truck to minimise the distance the liquids need to be transferred, pumped or gravitated.

Liquid ingredient delivery vehicles should be able to freely access the storage tank inlet, or take-off point, without interfering with the usual movement of feed delivery vehicles.

Topography and drainage

To protect against accidental spills or leaks, liquid feed storage systems should preferably be located in the controlled drainage area (CDA) of the feedlot. The liquid feedstuffs storage area could be bunded, as these products are difficult to clean up if spilled.



Delivery vehicles need all-weather and convenient access to the tank inlet or take-off point.

Liquid feed characteristics

Some physical properties of various liquid feedstuffs are provided in Table 1, below.

Table 1. Physical properties of some liquid feedstuffs.

Feed	Density (kg/m ³)	Viscosity (Centipoises)
Molasses	1400–1480	9,600
Glycerol	1,260	1,200*
Peanut oil	920	38
Cotton seed oil	880–930	62
Palm oil	890–920	43

*at 20°C

Types of storage

Liquid ingredients are typically stored in horizontal or vertical above ground tanks, with a flat or conical bottom. Tanks with a conical bottom require a metal stand because the pump and hoses will be placed at the bottom of the cone.

Conical bottom tanks allow all of the material to be pumped easily from the tank. The floors of flat-bottom tanks should be domed slightly to achieve complete emptying and periodic dewatering. Storage tanks should allow for periodic bleeding-off of any water that may separate to the bottom of the tank.

Liquid feeds can be stored indefinitely in steel, fibreglass or polyethylene tanks. Concrete tanks may require sealing to prevent corrosion by the liquids. Below ground concrete tanks, or HDPE-lined earth reservoirs (e.g. for molasses), are less common because of costs and practicality of management.

Separate tanks should be used for each liquid feedstuff. Mixing products in the same tank sometimes can result in reactions that make pumping difficult, or cause ingredients to separate or precipitate.

Any second hand tank must be cleaned effectively before use, especially if it has contained fuels, oils or cleaning chemicals.

Storage capacity

The minimum capacity of the storage vessel must be greater than the anticipated size of the delivery vehicle (and multiples thereof), with allowance for additional storage in the event of a supply interruption.

Liquid feedstuffs are usually transported in semi-trailers or B-Double vehicles with a loaded capacity of about 25t and 38t respectively. Storage volume can be estimated using the density data in Table 1.

Most suppliers of liquid pre-mixes use trucks with a number of smaller tanks so that various pre-mix formulations can be delivered at one time.

Installing at least one spare storage vessel will enable each tank to be drained completely and remove impurities, residue or sludge before refilling. This can be important when using molasses and some vegetable oils, as they may solidify in cool climatic conditions.



A well-prepared site with a solid foundation for liquid ingredient storage tanks. Flat-bottom concrete tanks are commonly used.

The capacity of storage tanks is usually specified as either

- Brimfull capacity – the maximum volume of fluid held without overflowing.
- Nominal capacity – maximum volume of fluid that may be stored in the tank as identified by the tank manufacturer.

Foundations

The foundations and/or base of the storage must be capable of withstanding the mass of the fully loaded storage vessel. See Table 1 for bulk densities of typical liquid feeds.

Foundation design is more critical with vertical or overhead tanks, as these are engineered to support liquids in a vertical plane with pressure exerted and distributed evenly around the base support frame. Guidance is recommended from a structural engineer for foundation design requirements for vertical tanks.

Construction

Concrete molasses tank construction should be monolithic (i.e. no joints in the floor or walls) to avoid seepage of molasses into joints - with subsequent deterioration of the concrete. A minimum 50mm cover should be put over the reinforcing steel and the entire mass of concrete should be protected with a recognised sealing and hardening agent.

To facilitate draining, the floor of a concrete tank may be constructed with a fall of about 5% (150mm in 3m) to its centre to form a dome shape.

Steel storage tanks that will hold liquids with a specific gravity of greater than 1000kg/m³ must be of stronger construction than those for use with water - and designed for this. Steel tanks are best emptied using a cone-shaped base.

Heating

For liquid ingredients that thicken at lower temperatures, storage facilities must be protected from the temperature drop by heating insulation, locating below ground or by housing the tank and handling equipment indoors. Insulation can be provided with 50mm thick glass fibre, or mineral wool.

Stored molasses should be kept at a temperature range of between 20-38°C to ensure the contents remain able to be pumped and can drain freely from the tank. In colder areas, molasses may need to be heated to a temperature of 32-38°C using water circulating through heating coils. A suitable heating system could be installed in a smaller tank holding approximately one day's supply and which is topped up daily from a larger storage tank. In a smaller installation, the storage and heating tank could be the same vessel using a domestic type of hot water boiler. Heating with low-pressure steam, or running steam lines alongside a molasses pipe, may ultimately result in caramelisation and blockage. Surfactants are available to help molasses remain liquid at lower temperatures.

Some liquid products, such as fats, will solidify when exposed to low temperatures and heating coils can be added to the storage vessels.



Liquid ingredients can be stored in various types of storage vessels and configurations. These are conical-bottom, HDPE tanks.



A bank of conical and flat-bottom steel tanks. Filling point is easily accessible at ground level, or at the base of conical tanks. Note there is insulation on some tanks to keep liquid warm and reduce viscosity.



Insulation may be required for those liquids that thicken in low temperatures.

Delivery lines may also need to be heated to prevent products from solidifying in cold weather.

Molasses can be supplied with a surfactant added and this can reduce the need for heating in colder areas.

Handling equipment

Some liquid feedstuffs that are high in moisture (e.g. condensed distillers solubles) may freeze during the winter, while molasses and molasses-based products will thicken and make pumping difficult.

Positive displacement pumps are typically used for handling liquid commodities and may be of gear, sliding vane or reciprocating type. Centrifugal pumps are rarely suitable. Positive displacement pumps maintain pumping efficiency at variable motor speeds and can pump low and high viscosity fluids and small solids. These also have a low Net Positive Suction Head (NPSH), a high suction lift capacity and can provide accurate flow rate measurement.

Positive displacement pumps need precautions on both sides of the pump. On the suction side, pumping liquid from a closed vessel could result in a collapse of the tank and piping. On the discharge side, it is important to check for closed valves, or relief valves, to prevent danger to operating personnel, damage to equipment and loss of product from blown fittings.

The pump and motor should have sufficient capacity to deliver the liquid feedstuff to the delivery point fast enough to ensure efficient loading of the feed truck.

For tanks housed indoors, the distance from the bung of the tank to the pump should be as short as possible to minimise the chance of blockage in the pipe during cold weather.

Corrosive liquid ingredients, such as condensed distiller solubles, require more maintenance of their pump and handling equipment than do less corrosive products, such as molasses-based supplements.

Piping for liquid feedstuffs may be made of steel, cast iron or polythene or PVC of adequate strength for the duty to be performed. Pipes should generally not be less than 50mm in diameter, with a minimum number of changes in direction. Suction lines for viscous liquids, such as molasses, should not be less than 75mm.

Unrestricted valves, such as gate or plug valves, minimise diameter reductions and are recommended to ensure adequate flow rates. Rising spindle-type gate valves will also show whether the valve is closed or open. Ball valves may inhibit flow rate.

Storage should be filled via valves located near the base of the tanks, or silos, to enhance mixing of old or settled products. This also prevents the operator from having to work at height to access the valves. For quick filling or emptying of storage vessels, pipe and valve diameters should be at least 125mm.



Handling equipment should be of adequate size to deliver the liquid to the delivery point. Larger diameter pipes are required for viscous feedstuffs, such as molasses.

Metering and proportioning

Liquid ingredients must be added in feed formulations accurately, consistently and at the desired application rate. Correct application can be achieved by a metering pump below a constant head tank, a liquid batching system or weighed to the feed truck using the vehicle weigh scales.

Regardless of the metering method used, application should be checked frequently by measuring test quantities via a valve downstream of the meter.

Ventilation

Regardless of its type of construction or location, the tank must have adequate vents. This is to minimise condensation (which causes corrosion in steel tanks), vent fugitive emissions and prevent a vacuum being drawn on the tank by pumping - which could cause it to collapse.

Typically, molasses is relatively safe to handle. But if water has entered the tank, fermentation could generate carbon dioxide gas, which is asphyxiating, and alcohol vapour, which is flammable.

If any fermentation is suspected to have occurred, the tank should be thoroughly ventilated before entry and any residue should be thoroughly cleaned out before any heat-generating work, such as welding, is carried out on the tank.



Level indicator fixed to the outside of a storage tank allows inventory levels to be easily checked and recorded.



Liquid feed-out station. Storage tanks and pumping equipment are located on the outside of commodity shed wall with a delivery pipe through the wall.

Quick tips

- Liquid feed storages should be located near the feed preparation area, but have safe access for delivery vehicles without interfering with feed trucks.
- Liquid storage tanks and delivery lines may need to be heated in colder climates.
- Provision should be made in the storage tank for bleeding-off water that may separate to the bottom of the tank.
- Fill molasses tanks from the base, as agitating the molasses helps to prevent the accumulation of impurities.
- Molasses and molasses-based products are low in moisture but will thicken at low temperatures, making pumping difficult.
- A sight gauge or float gauge on a liquid tank makes it easier to check inventory.

Further reading

McElhiney, R.R (ed) 1994, Feed Manufacturing Technology IV, American feed Industry Association Inc, Arlington, VA.

Lardy, G. 2013, AS-1272 Handling Liquid Feed Commodities, NDSU Extension Service, North Dakota State University, Fargo, North Dakota.

Pumpschool, 2007, When to use a Positive Displacement Pump
<http://www.pumpschool.com/intro/pd%20vs%20centrif.pdf>

Food and Agriculture Organisation, Appendix XI – Bulk density, palatability and particle size
<http://www.fao.org/docrep/S4314E/s4314e0q.htm>

Bundaberg Molasses
<http://www.bundysugar.com.au/molasses/intropastureplus.html>

Standards Australia (1998). Steel structures, AS 4100-1998, Sydney, NSW, Standards Australia.

Standards Australia (2002). Dead and live load combinations, AS/NZS 1170.1-2002, Sydney, NSW, Standards Australia.

Standards Australia (2005). Cold formed steel structures, AS/NZS 4600-2005, Sydney, NSW, Standards Australia.

Standards Australia (2009). Concrete construction (including reinforced and prestressed concrete), AS 3600-2009, Sydney, NSW, Standards Australia.

Standards Australia (2011). Masonry (including masonry-veneer, unreinforced masonry and reinforced masonry), AS 3700-2011, Sydney, NSW, Standards Australia.

Standards Australia (2011). Wind Loads, AS 1170.2-2011, Sydney, NSW, Standards Australia.



FEEDLOT DESIGN AND CONSTRUCTION

35. Feed mixing and delivery

AUTHOR: Rod Davis

Introduction

Thorough mixing of a ration provides a homogenous composition so that every animal receives the required intake of each ingredient. It may also assist palatability by helping to mask the flavour of less palatable ingredients.

Mixability may be affected by the feed commodities being used, mixing action, mixing time, mixing sequence and accuracy of adding each ingredient. Particle size may range from coarse grains and roughage to liquids and fine chemical particles.

The desired process is a well mixed ration in which individual feed ingredients have been accurately batched together by weight, uniformly mixed and then delivered to the cattle in a timely and efficient manner at a repeatable time of day.

The components of the feed mixing and delivery system are feed ingredient storage areas (see *Sections 30 to 34*), feed batching and mixing equipment and equipment to deliver the mixed feed to the pens.

Design objectives

The feed mixing and delivery system should be designed, constructed and maintained to ensure that

- The overall system will meet the requirements for mixing and/or delivery of the ration.
- Batching of feed ingredients is accurate and efficient.
- Spillage and wastage of ingredients is minimised.
- Ration is thoroughly mixed without damage to ingredients.
- Correct quantity of the appropriate feed is delivered to the cattle.
- The system and the equipment are efficient, safe and convenient to operate, even in adverse weather conditions.
- Equipment is maintained in good working condition.

Mandatory requirements

Feed delivery vehicles should be compliant with state regulations for use on public roads. This may mitigate against any claims of negligence in the event of an accident in the feedlot.

Design choices

Function of mixer

The mixer has to uniformly blend particles of different sizes, moisture content and bulk density into a ration. Samples taken from the beginning, middle, and end of unloading should show no significant differences in ration composition when the load is fed to all pens.

Over-mixing can be as detrimental as under-mixing in achieving optimum uniformity and trials need to be carried out with different ration formulations to find the optimum mixing time for each combination of ration ingredients.



A tractor drawn horizontal vertical screw mixer set up as a stationary unit.

Feed particles are moved mechanically with augers, reels, chains and drums. This may reduce the size of some particles, which can have a beneficial or detrimental effect.

Manufacturers produce feed mixers of varying designs and operational differences and the feedlot has to select a design that suits its feed ingredients, physical properties of the ration, feedlot capacity and method of feed delivery.

All the mixers on the market are batch mixers, in which feed ingredients are added one at a time until the required weight of each specific ingredient is reached and the batch is complete. The order of adding feeds can affect the mixing ability and/or time of mixing and this may depend on the type of mixer and its mixing action.

Mixers can be categorised into stationary or mobile mixers, with either horizontal or vertical mixing actions.

Vertical mixer

The vertical mixer consists of a large tub with one or more vertical screws centred in the tub. The screws elevate the ingredients to the top of the mixer, where they fall by gravity to the bottom to be mixed and re-elevated. The continuous lifting and falling action creates a blended mixture of ingredients. Knife sections may be attached to the screw flighting to cut material, such as hay or straw. Movable shear or restrictor plates on the tub wall provide a shear surface, increasing the ability to process and reducing the fibre length of roughages.

Vertical mixers are the most common type found in small trailer mounted mixers, but are now also available in larger sizes for truck mounting.

Horizontal screw

Horizontal screw mixers consist of a series of augers mounted on a horizontal rotor in a hopper.

Auger mixers use one to four augers to churn the feed in a hopper. The flighting of the auger(s) moves the feed towards the middle of the mixer where it bubbles to the top, toward the sides and back down to the augers.

The mixers have one or two counter rotating auger(s) and/or flighting, moving feed in the opposite direction to the other augers. Feed moves from end to end and from bottom to top.

In many mixer designs, notched auger flighting and/or knife sections are attached to the auger flighting to process roughage and improve its incorporation into the ration. Design differences in these mixers include the number of augers, the rotation speed of the augers, the auger diameters and the auger flighting design.

Horizontal screw mixers are more efficient than vertical types in blending small quantities of liquids, or in mixing ingredients with different particle sizes. Liquids are generally placed in the mixer after the grain and roughage commodities to enhance thorough mixing and to prevent balling.



A tractor-drawn vertical mixer.



Horizontal screw mixing augers in the feed truck.

Horizontal paddle mixer

The paddle type mixer is quickly becoming the predominant design used in larger feedlots in Australia. It can increase mixing efficiency, achieving soft mixing action for consistent grain integrity, consistency of the ration reduction in fines and speed of mixing.

The horizontal paddle type mixer combines a set of augers and a paddle in a hopper. The feed is lifted and tumbled by the paddle, moving it upwards to the upper and lower side augers. The augers provide a mixing action and move the feed from end-to-end. The rotor can be configured with three or more paddles (i.e. up to five or six). The paddles can also be staggered along the shaft of the rotor to match the ration density and improve mixing speed and performance.

The tumbling action mixes the lighter roughage and high moisture ingredients without grinding or high pressure feed movement. The side augers prevent dead spots and corner pile up.

These mixers usually discharge the mixed product from the bottom of one side, using the same mixer blade action. On truck mounted systems, the paddle and augers may be stopped or run while the truck is mobile, but must be working during feed delivery to aid the flow of feed from the delivery chute to the feed bunk.

Paddle mixers are available in various configurations, with mixing capacities typically ranging from 15 to 26m³.

Stationary mixers

These mixers are permanently positioned and so require other equipment for feeding out the mixed ingredients to the feed bunks. The vertical feed mixer is often less efficient than the horizontal mixer because of its smaller size, restricting the level of liquid addition and requiring a longer mixing time.

Stationary mixers are typically driven by three-phase electric motors, the size of which depends on the type and capacity of the unit (e.g. screw, paddle). As a guide, a stationary paddle type mixer with a capacity of 15m³ requires a 30kW electric motor.

Mobile feed mixer

The mobile feed mixer can either be trailed (behind a tractor) or permanently mounted on a truck. These allow the feed to be mixed on the go before the feed is delivered, avoiding the need for double handling and giving faster turn around times. Tractor drawn feed mixers are commonly used in small to medium sized feedlots, with truck mounted mixers typically used in medium to large feedlots.

The truck mounted mixer increases feed mixing and delivery efficiency through faster delivery and less time for the ration to be mixed. The mounted mixer feeder caters for all types of ingredients in the ration formulation— from grains to liquids. Depending on the size of the feedlot, using more than one truck allows one to be delivering the feed while the other is being loaded. The most common types of truck mounted mixer feeders are the horizontal screw mixer and the horizontal paddle mixer.



Paddle type mixer in the feed truck. The paddles can be seen under the loader bucket. Liquid supplement nozzles are under a shield.



This 5.5 tonne tractor drawn horizontal mixer requires 95–105kw at the PTO.

Weigh scale

Weigh scales can be fitted to the loading unit (e.g. articulated, front end or telescopic loader), or to the mixer unit to accurately weigh and blend the ration ingredients. Electronic digital readout scales use load cells or weigh bar designs to weigh the loading of each ingredient in the mixer and are accurate to 0.25-1%.

The weighing system is usually supported at three or four points (cells) on the mixer chassis, depending on the design of the weigh sensors. The same weighing system is then used to measure the amount of mixed feed given to each pen of cattle.

Magnet

A magnet is attached at the discharge chute of the feed delivery truck to pick up metallic foreign material before it enters the feed bunk. This may be standard, or an option, on the mixer and should be considered part of a basic mixer system.

Safety

Safety should also be considered in mixer design and use. Metal steps or a ladder should be used to mount the mixer for inspection, while allowing for safe filling of the mixer.

Power take-off (PTO) shields should always remain in place and no safety shield should ever be removed.

Never try to dislodge wrapped hay from an auger or other moving part of the mixer while it is running.

Mixer sizing

The mixer size will be governed by the feedlot size, number of different rations being fed, ration density, feed intake and the number of times per day cattle are fed. Economics, labour availability and feed management will also help with decisions about mixer size

The capacity of a mixer is the total volume of the mixing compartment, but manufacturers may rate capacity at 60-90% and these figures should be followed.

Overloading mixers beyond the rated mixing capacity increases the mixing time required for a uniform mix and may result in spillage and feed wastage. This is particularly applicable to horizontal paddle mixers that rely on each paddle coming out of the feed at the top of its rotation to achieve proper mixing.

Feed delivery systems

Feed delivery systems are generally planned during the design phase of a new feedlot. The optimal layout and design of the feedlot is often site and size-specific and this will ultimately affect which feed delivery system is best and the energy efficiency of the system. See *Section 2 – Feedlot site layout*.

The distance travelled to deliver the feed rations to livestock, often twice a day, makes fuel, labour and equipment costs a high priority in the design phase. The components of the feed delivery system, once installed, are not frequently changed because of the high capital costs involved with infrastructure construction. These may



Typical bunker feed delivery system. The loader transfers ingredients to a truck mounted mixer, which then mixes on the go during delivery to the pens. Liquid supplements are loaded at a separate location.

be changed during major renovation of an existing feedlot, such as when increasing the feedlot capacity.

The feed delivery system will be determined by the type of feed-out system installed. Self-feeder bins are commonly used in small or opportunity feedlots, whereas open feed bunks are used in large or commercial feedlots. See *Section 19 – Feeding systems*. The components of various types of feed-out systems are discussed below.

Bunker system

The bunker system consists of a storage shed where each feed commodity is stored in separate bunkers (see *Section 31 – Commodity storage*). Commodities are transferred from the bunker into a truck mounted mixer, tractor drawn mixer trailer or stationary mixer or a batch box using a front end loader or equivalent.

Each commodity has a predetermined weight, monitored by weigh scales mounted on the respective mixing equipment—loader, batch box or mixer/feed-out unit.

Liquid supplements are typically loaded through an overhead piping system, remotely controlled by the operator (see *Section 34 – Liquid feedstuffs*). The load is mixed thoroughly and delivered to open feed bunks at each designated pen. The weight of feed delivered to each pen is recorded using the weighing scales on the feed-out equipment.

The biggest inefficiency with this system is the time spent operating a loader between the various feed commodities, the time spent waiting for a feed truck to return for loading or, more commonly, feed trucks waiting in queue to be loaded when there is more than one feed truck. In smaller operations, feed-out operators can load their own mixer units.

Stationary mixer

This system uses a stationary mixer located adjacent to the commodity bunkers. The loader places the correct weight of each ingredient into the stationary mixer using the scales fitted to the mixer and the ration is mixed before the feed-out unit arrives. The fully mixed load is then augured into the unit.

Large feedlots can have more than one stationary mixer and these can feed a series of overhead storage hoppers—one for each ration. The feed-out unit can then be quickly loaded with a fully mixed ration from the storage hoppers. As the feed-out units do not have to mix, these can be much larger than conventional feed trucks.

However, using feed-out trucks without mixing capability usually means that failure of the stationary mixer will stop the feeding process.

Batch-box system

The batch-box system is designed to streamline the feeding processes; It is similar to the bunker system, but incorporates a stationary side-dump batch-box. The side-dump batch-box is hydraulically raised and lowered, powered by an electric motor and controlled via remote control. The commodities for a batch of feed are loaded from the bunkers into the batch-box using a front end loader, or similar, while the feed-out units are delivering the current load.

The batch-box is mounted on load cells to record the weight of each ingredient added. Once the feed-out unit returns, the complete ration



The vehicle loading area is stepped down (or the commodity area raised) so the loader can load the vehicle safely and easily.



A ramp installed at the edge of the commodity shed aids the loading of feed trucks.

is dumped into it in 30 seconds (minimum) and then mixed in the feed-out unit as it travels to the point of feed-out.

Dual batch-boxes are commonly used so that while one is tipping, the other is being filled. The boxes are mounted on a static load cell platform - potentially providing more accuracy than with a mobile feed truck.

The batch-box system reduces loading variability, allows a faster turn over of trucks and more efficient use of equipment. Feedlot feeding capacity could be increased with the existing mixing and feed-out equipment.

Batch-boxes can be installed in a new site development, or successfully integrated into existing bunker systems.

The key considerations for integration into existing bunker systems include

- Site selection
 - Maximise use of existing shed and structures – consider available area, height restrictions, foundations, power supply.
 - Minimise efficient travel distances for feed-out equipment – consider loaders, feed truck turn around.
 - Access to liquid ingredient delivery systems – consider liquids could be added separately before or after the batch-box.
- Site preparation
 - Modifications to infrastructure – consider foundations, sheds, liquid feedstuffs pipework, power supply.
 - Construction/installation of new infrastructure.
- Alternative feeding arrangements during construction/installation.

For new site developments, incorporation of a batch-box system needs to align with the location of the system, including proximity to liquid storages, travel distances from commodity storage bays and vehicle turn arounds. *Section 31 – Commodity storage* illustrates various commodity shed layouts with an integrated batch-box system.

The supplier of the batch-box system should be able to provide details such as foundation design and power requirements.

Mobile delivery equipment

The ration is transported from the commodity shed to the cattle using mobile delivery equipment. Mobile units include truck mounted vertical and horizontal augers, horizontal paddle mixers and tractor drawn auger and vertical screw mixers or non-mixer feed-out vehicles.

Larger mixers in mobile delivery equipment require larger and more powerful tractors or trucks. Equipment manufacturers will specify the power required to operate a particular mixer. A tractor is often dedicated to the daily operation of the mixer trailer.

Feed management system

The feeding system, from ration mixing to delivery to the feed bunk, should be managed to ensure a consistent level of nutrients is presented to the cattle in a consistent form and a timely manner.



This dual batch-box system is located externally to the commodity storage. No liquid feedstuffs are added at this point.



A dual batch-box system installed at the end of the commodity storage. The loader can continue to load one batch box while the other is tipped into the feed truck. The front of the batch-box holds liquid dispensing equipment.



A dual batch-box system installed inside and at the end of the commodity storage.



Selection of make and model of commercial feed delivery trucks is driven by personal experience and the size of the feedlot. This imported left hand drive truck delivers feed to the left.



A feed-out chute on the same side as the vehicle operator minimises spillage and wastage when dispensing feed (i.e. right hand drive vehicle with right hand side delivery chute). A rubber extension on this chute minimises damage from impact with the feed bunk.

There are several proprietary feed management software systems available (e.g. FY3000 Feedbunk, FeedIT and Possum Gully). The software systems are usually an integrated feedlot management system, with various management features and tools. Some feedlots (large and small) have developed their own feed management software.

Most of these integrated management systems import inventory data (e.g. cattle, feed), cattle treatments, feeding records and export financial data to financial and accounting software programs to generate detailed reports.

The feed management system must link the feeding system with the cattle management system (e.g. NLIS, animal health treatments). The commonly used radio frequency (RF) datalink (wireless) transfers feeding protocols and instructions to the feed preparation, loading and mixing areas.

This allows feedout operators to accurately determine ration formulations and load sizes, including weights of each ingredient to be included and mixed in each specific load.

The RF datalink is integrated with the feed delivery vehicles to ensure the actual weights of loaded ingredients and feed ration are allocated accurately to the intended pen.

The system will also capture the actual weight of each ingredient added to each load and the actual weight of mixed feed provided to each pen. This data is transmitted from the mixing equipment and the feed-out equipment directly to the feedlot office and captured by the feedlot's main computer system.

Quick tips

- Rations with a high percentage of roughage will require larger capacity mixing equipment.
- Selection of the most suitable type of mixer will depend on a wide range of factors.
- Select the mixer size based on budget, feedlot capacity, ration density, feed intake and number of times cattle are fed each day.
- The size and layout of the feedlot will determine the type, size and number of feed delivery vehicles required.
- Manufacturer claimed mixing times are often overly optimistic, even for ideal ingredient composition and conditions.
- Conduct a mixer test for each particular ration to determine the optimum mixing time for each particular mixer/ration combination and ration. This ensures that the ration is evenly mixed when delivered to the first pen.
- Batch-boxes increase the efficiency of feed delivery, especially in larger feedlots (e.g. greater than 15,000 head).

Further reading

Bunk Management for Profit. R. Pritchard. <http://www.beeflinks.com/BunkMngt.pdf>

Loerch, S.C. and Fluherty, F.L., 1998, Effects of Corn Processing, Dietary Roughage Level, and Timing of Roughage Inclusion on Performance of Feedlot Steers. *J. Anim. Sci.* 76:681-685.

Loerch, S.C., 1990, Effects of Feeding Growing Cattle High-Concentrate Diets at Restricted Intakes on Feedlot Performance. *J. Anim. Sci.* 68:3086-3095.

Loy, D., 2010, Feed management- Bunker to Bunk. Iowa Beef Center

Madden, D.M., 2006, Fast Feeding – Incorporation of Batch Boxes into a feeding system. 2006 BeefEx proceedings, October 10-12 Royal Pines Resort, Gold Coast, QLD.

Faulkner, D.B. and Berger, L.L., Limit Feeding Beef Cattle. *Beef Cattle Handbook*. <http://www.iowabeefcenter.org/pdfs/bch/05175.pdf>

Feed Batching Systems – Feeding Systems LLC. <http://feedingsystems.biz/>



FEEDLOT DESIGN AND CONSTRUCTION

36. Hospital and recovery pens

AUTHOR: Robyn Tucker



Recovery pens are separated to segregate cattle by type, severity of illness or treatment, or to keep cattle from a similar area of the feedlot together.

Introduction

Early detection and treatment of ill or injured cattle will optimise welfare and productivity and minimise mortalities. Returning treated animals straight back to production pens may increase the risk of cross infection. Larger feedlots generally provide a hospital, treatment pens, convalescence (or recovery) pens and/or salvage pens to treat and hold sick or injured cattle before they are returned to production pens or exit from the feedlot.

This section explains the design principles of hospitals, sick pens, convalescence pens and salvage pens.

Design objectives

Hospital and recovery pens should be designed and constructed to

- Provide facilities for the effective diagnosis and treatment of sick or injured cattle.
- Provide facilities that allow for effective ongoing monitoring of sick or injured cattle.
- Provide accommodation that promotes the rapid recovery of sick or injured cattle.
- Minimise the risk of transferring disease to other cattle.
- Provide a safe working environment for people.



A fully-covered hospital. Roof cladding allows light with less sharp shadows.

Mandatory requirements

Compliance with

- Australian Animal Standards and Guidelines for cattle (DAFF, 2013).
- National Guidelines for Beef Cattle Feedlots in Australia (MLA, 2012a).
- National Beef Cattle Feedlot Environmental Code of Practice (MLA, 2012b).
- Storage and Handling of Agricultural and Veterinary Chemicals (AS 2507-1998).
- NFAS standards (AUS-MEAT, 2011).

Design choices

The type of hospital and associated treatment, convalescence and salvage pens required depends on the feedlot size, layout, risk profile and preferred animal health management method.

A small feedlot may be able to use the induction yards as a hospital treatment facility. But larger feedlots need to provide purpose built hospitals and recovery pens.

Feedlots with short-fed stock, high turnovers or that receive cattle purchased from saleyards have higher risk than longer fed cattle feeding operations or feedlots with predominantly Bos Indicus cattle types. The higher the risk, the more space is needed for treatment, convalescence and recovery.

Sick cattle may be treated and quickly returned to their production pen (up-and-back system) or held for two days before being returned



An animal in the crush ready to receive treatment.

(two-day system). In a bio-containment system, animals that have been treated more than once are sent to new production pens.

The up-and-back and containment systems are used regularly in feedlots. The bio-containment system is more common in smaller operations and feedlots in which all the cattle are owned by a single entity.

Ideally, hospitals with associated treatment, convalescence, recovery and salvage pens should be located centrally to the production pens because sick or injured cattle should not be walked long distances or uphill. For this reason, multiple hospitals may be needed at large feedlots. Hospitals, treatment pens, convalescence pens and recovery pens may be physically separated from production pens either by double fencing or solid fencing to minimise the risk of disease transfer to healthy stock.

As there will be some mortalities, hospitals are usually situated towards the down slope end of the feedlot complex to allow for ready transfer of mortalities to the post-mortem, disposal or composting area. Vehicles must be able to reach hospital pens.

Hospital facilities should include the following

- A shaded treatment area with a crush that minimises injury during restraint.
- Rubber matting on the floor of the entire hospital area.
- A foot bath.
- Weigh cells fitted to the crush to determine the correct dosage rate of medicines.
- Locked medicine storage, including fridge (for smaller feedlots, this could be located elsewhere on-farm with medicines transported to the hospital as needed).
- Facilities to store, clean and sanitise instruments (including hot water).
- Facilities for disposal of sharps, such as needles and blades.
- Facilities for disposal of other packaging.
- An area to record and store details of treatments.
- A post-mortem area.
- Data connection to the processing facility/office for database management.

A suggested ratio is one hospital facility (with multiple treatment, convalescence and recovery pens) per 6000 head of cattle and occupying 2–5% of total feedlot capacity. For a large feedlot (e.g. 20,000 SCU or greater), a minimum of five large treatment pens, three convalescence and recovery pens and at least one salvage pen per hospital is recommended.

In addition to the general pen design principles, provision should be made for:

- About 50% more pen space for sick cattle in the treatment pens (e.g. 20–25m²/SCU). Over crowding is a major reason for failure in feedlot hospital pen systems.
- Shallow, wide treatment pens so that sick cattle do not have to walk far to access feed and water. Convalescence and recovery pens can have a similar size and stocking density to production pens. Salvage pens can be the same size as treatment pens. Providing multiple pens also allows cattle on similar treatments



Rubber soft-flooring in handling areas.



Veterinary medicines require appropriate storage facilities.



Sink with running water for good hygiene for the handler and the animal being treated. Note disposal containers for used needles and blades.



Soft bedding in treatment pens for cattle with foot or leg problems.



Bins for disposal of waste items.

- to be grouped together. Separate pens for animals with foot problems should be bedded with wood chips or straw, but this should be replaced regularly to avoid a Salmonella outbreak.
- A clean feedlot pad – the pens should be well drained and frequently cleaned. The pad should be well maintained and kept as dry as possible. The addition of soft bedding material is recommended.
- Protection from adverse environmental conditions such as mud, dust and extreme heat. North-south shade should traverse the pen during the day.
- Additional feed bunk space at 45–60cm per head. This is to encourage consumption and reduce competition between sick or injured cattle. Hay racks may be needed in the treatment and salvage pens - with good access for delivery of hay bales.
- Good access to palatable, and preferably cool, water - but with only one trough per pen to minimise cross-infection between pens. Water released from the trough during cleaning should be directed away from the pen area, possible through a sewer system.

Quick tips

- The hospital pen/s should have rubber matting or other soft flooring over the base, shade, a good crush, storage for medicine and instruments and an area to record and store details of treatments.
- The hospital area should have adequate pens for convalescence and recovery, with the number depending on the size of the feedlot and background of cattle being fed.
- The treatment pens should have 50% more pen area than in production pens, shade and 45–60cm of bunk space per head.
- Troughs should not be shared between pens and should contain clean cool water.
- Treatment pens for cattle with foot problems or leg/hip injuries should have clean, soft bedding.

Further reading

- AUS-MEAT, 2014, NFAS Rules & Standards (April 2014), AUS-MEAT Limited, Brisbane, Qld.
- Boyles, S., Loerch, S., Fluharty, F., Shulaw W and Stanfield H 1998 “Feedlot Management Primer”, Ohio State University Extension, Chapter 2: Shipping and Receiving Cattle, pp. 8-19,
- Griffin, D.D., Perion, L. and Hudson, D. 1993 “G93-1172 Starting Cattle”, Historical Materials from University of Nebraska-Lincoln Extension, Paper 342.
- Paine, M., Teter, N. and Guyer, P., “Feedlot Layout” in Great Plains Beef Cattle Handbook, Cooperative Extension Service of Great Plains States, Publication GPE-5201, pp. 5201.1- 5201.6
- Thompson, D.U. 2008 “Feedlot Hospital Management”, North American Veterinary Conference, Volume 22, Orlando, Florida, pp. 62-65.
- USDA, APHIS and the Center for Food Security & Public Health 2011 “Beef Feedlot Industry Manual: FAD PReP Foreign Animal Disease Preparedness & Response Plan”, Iowa State University, Ames
- White, G., Rice, D., Hudson, D. and Grotelueschen, D. 1988 “G88-878 Management for Disease Prevention in Feedlots” Historical Materials from University of Nebraska-Lincoln Extension, Paper 337.



FEEDLOT DESIGN AND CONSTRUCTION

37. Stables

AUTHOR: Robyn Tucker



The aisle between two rows of stalls should be at least 3m wide.



Run-out area adjoining stables. Note a feed and water trough is provided in the run-out area.



Exercise/training yard with sand bedding and lined inner walls

Introduction

Many feedlots use horses for monitoring cattle (pen riding) and for moving stock around the feedlot. For their optimal health and welfare, horses should be provided with a clean shelter (usually a stable or stall), a run-out area, suitable feed, watering facilities and areas for husbandry procedures.

Design objectives

The stable, and associated horse facilities at a feedlot, should provide

- a comfortable environment for the horses, including protection from the sun, wind, dust, storms and constant or intermittent loud noises
- a safe working environment for people
- a hygienic, well-ventilated environment
- sufficient space for each horse to lie down and comfortably turn around
- an adequate run-out area with suitable space for movement connected to the stables
- a large spelling area
- access to clean and reliable water
- storage for horse feed
- a saddle room to store pen rider equipment and tack
- a storage area for bedding material.

Mandatory requirements

Compliance with

- Australian Animal Standards and Guidelines for Horses (DAFF, 2013).
- National Guidelines for Beef Cattle Feedlots in Australia (MLA, 2012a). This states that the water must be suitable for livestock use.
- National Beef Cattle Feedlot Environmental Code of Practice (MLA, 2012b). Performance measure 1.5.2 states that a feedlot has a water supply able to sustain the operations of the feedlot under normal conditions.
- quality standards for livestock drinking water as outlined in the Australian and New Zealand Guidelines for Fresh and Marine Water Quality (2000) (ANZECC and ARMCANZ 2000).
- relevant state and local authority codes and regulations as applicable to feedlot development water licensing.

Design choices

Location

Ideally, stables should be located away from primary sources of vehicle movement, noise and dust. They should have good road access for delivery and retrieval of horses. Avoid the dusty and noisy feedlot environment, including feed preparation and storage areas and heavy vehicle movement.

Layout

Horses should be provided with a stable or stall to provide protection from the sun, wind, storms and dust, along with a run-out area. Stables or stalls should be large enough for the horse to lie down and comfortably turn around e.g. 100 m² per horse (typically 10 m wide and 10 m long). If stables are used, the stall gate will usually be left open to allow free access to an outdoor run-out area. The run-out area should be at least 300 m² per horse (typically 10 m wide and 30 m long). Some individual stables or stalls and run-out paddocks should be provided.

The total area needed for horse accommodation depends on the total number of pen riders, the number of horses each pen rider has and the area provided per horse. Not all pen riders will be working on any given day, while some pen riders have multiple horses that they rotate.

Stables or stalls can be set out in a single row but it may be more economical to build two rows that are separated by a common access/alley. The aisle between the rows of stables or stalls should be at least 3 m wide to allow access for vehicle or skid steer loader for stall cleanout.

Sick or injured horses should be confined to their stable or stall and run-out area. At large feedlots, one or two separate stables that are isolated from the main facility may minimise the risk of disease spread.

Because of the high levels of dust at feedlots, horses should be spelled from work every 3–4 weeks and at least every two months. Horses being spelled may be kept in paddocks on the farm, in backgrounding paddocks or on nearby agistment, with an area of 0.4–1 ha per horse.

Materials

Stable walls should be at least 2.75 m high. They should be built of a solid material that provides good insulation (e.g. timber or besser bricks). Metal sheeting is unsuitable as horses have kicked through it or caught their hooves underneath. To prevent injury and damage to the walls from pawing or kicking, the inside walls may be lined with rubber conveyor belting or smooth wooden planking to a height of 1.4 m.

Stable doors and stall gates should open outwards and be at least 1.2–1.4 m wide with no protrusions that could injure the horse or handler. Latches should be strong and easily turned with large, flush handles with no protrusions.

The stable or stall is a high traffic area. A 100 mm deep reinforced concrete slab with a 1 m wide apron into the run-out area should have a non-slip surface. Both the stable or stall area and the run-out area need gates for skid steer or loader access, and these could be located just below the stable or stall.

Fencing

The run-out area should have fencing 1.7–1.8 m in height, with a maximum panel length (between posts) of 2.3 m or 2.4–2.75 m including posts. Barbed or plain wire fencing is unsuitable due to the risk of injury to the horse. Posts can be 230–310 mm diameter timber or 76 mm diameter steel posts. Although concreting steel posts into the ground avoids the need for cap rails, these rails do make the fencing more visible to the horses. Rails may be steel cattle



Spelling paddocks with natural tree shade



Spelling paddocks with artificial shade – steel posts supporting suspended shade cloth



Bedding in stables with no adjoining run-out area. Note conveyor belting covering the iron sheeted wall at the back of the stall.



Bedding stockpile to the right of the stable complex.

cable or 150 mm x 50 mm hardwood rails, 150 mm diameter bush timber rails or 45 mm diameter steel piping. Cap rails can be 76 x 76 mm hardwood rails or 45 mm steel piping.

Entrance gates should be at least 3 m wide and internal gates 2.4 m wide. Gates must fit neatly to prevent horses from rubbing at corners and trapping their necks in gaps, which can cause choking.

While post and rail or steel cable fencing is preferred, this could be expensive for spelling paddocks. Alternative fencing needs to be easily visible and escape-proof.

Plain wire fencing or electric fencing can be used and should be at least 1.4 m high, have 5 wires (plain 2.75 mm or 11 gauge high-tensile), strainers at least every kilometre depending on terrain, 50 mm galvanised or treated posts every 30 m and wooden droppers every 3 m. Plastic objects placed along the fence can act as additional sight barriers. Objects that may cause harm to horses need to be removed.

Drainage

Good drainage will prevent wet, muddy conditions in the run-out area. Ideally, run-out areas should have similar compaction and a similar slope to the feedlot pens with drainage away from the stable or stall and directed to the feedlot drainage system. The roof of the stable or stall should have gutters that drain away from the horse complex.

Dust control and ventilation

As horses are susceptible to respiratory disease, hoses or sprinklers will suppress dust suppression in the run-out area. For good ventilation, stalls should be enclosed on the side that receives the prevailing wind and open on the alternate side.

Safety and power supply

Lighting should be provided within the stable and tie-up area for safety and ease of management during the early hours of the morning. Power may also be needed to allow for the use of clippers and other appliances.

Smoke detectors should also be installed for fire safety.

Feed

An average-sized stockhorse requires around 4–5.5 kg of chaff or hay per day. Horses should be fed using individual galvanised or plastic feed bins that hang on a rail or wall in the stall, and not fed directly from the ground. The feed bin should not have a sharp edge and should have a rim wide enough to prevent the horse from crib-biting. Trays that are too low may be damaged by pawing and there is an increased likelihood of fouling the feed.

Horses kept in paddocks may need supplementary feeding depending on the quality and availability of paddock feed.



Stable tie-up for shoeing and grooming.



Horse crush area for veterinary access or vaccinations.

Water

Clean water must always be available; horses will refuse to drink dirty or contaminated water. Self-filling bowls at a height of 1 m in the corner of each stable or stall are convenient and the regular inflow helps to maintain water quality. However, new horses may need to be introduced to their use.

Continuity of water supply is also essential. A typical 400–550 kg stockhorse will need approximately 16–22 L/day (4 L/100 kg liveweight per day) when resting in cool conditions, and 40–80 L/day when exercising or in hot weather.

Self-filling bowl waterers can fail, so unless there is a strict policy of checking all waters daily, an alarm that detects failure to refill is recommended. An alternative is to provide a larger trough in the run-out area.

Clean water must be continually available for horses kept in paddocks.

Husbandry

Facilities for the care and husbandry of the horses should be provided in close proximity to the stable area. These include

- tie-up facilities (horizontal pipe or hooks) – for saddling horses and for routine husbandry practices such as worming
- wash bay – a concrete pad with good drainage to the feedlot effluent system, possibly via sewer pipe
- shoeing area with tie-up facilities – a concrete floor, shelter from heat and rain but open enough to allow the farrier to escape a kicking horse.

Storage

A saddle or tack room should be provided to store pen rider equipment. Horse feed can be stored in a large saddle room, otherwise in a separate weatherproof shed.

Purpose-built bunker storage or a just a stockpile area should be provided close to the stable complex to store fresh bedding.



Concrete pad used as a washdown area for horse.



Saddle room for storing saddles, tack and wet weather gear.

Quick tips

- Locate horse accommodation away from vehicle traffic, dust and noise, ideally within the controlled drainage area
- Provide at least 100 m² of stable or stall area and at least 300 m² of run-out area per horse
- Provide a concreted floor with good bedding in the stable or stall and a run-out area with similar compaction and slope as the feedlot pens, with drainage directed to the feedlot drainage system
- Choose materials for the stable walls that are strong, provide good insulation and are safe for the horses (e.g. timber or besser blocks possibly lined with rubber conveyor belting, or smooth wooden planks)
- Sprinklers or hoses should be available for dust suppression in the run-out area
- Feeders should be positioned with the tray about 1 m above the floor.
- Self-filling water bowls are convenient but must be checked regularly or have a failure detection system.
- Steel cable or post and rail fencing are suitable for the run-out area
- Tie-up facilities, a wash bay, a concrete floored shoeing area with shelter and weatherproof storage areas for tack, rugs and feed need to be provided near the stable area
- Horses being spelled need suitable stable or paddock areas, along with shelter, feed and watering facilities.

Further reading

ANZECC, 2000, Australian and New Zealand guidelines for fresh and marine water quality: Volume 1 - The guidelines. Australian and New Zealand Environment and Conservation Council Agriculture and Resource Management Council of Australia and New Zealand – 2000.

DAFF, 2013, Australian Animal Standards and Guidelines for Cattle, Department of Agriculture, Forestry and Fisheries, Australian Government.

Department of Primary Industries ND “Guidelines for Minimum Standards for Keeping Horses in Urban Areas (Factsheet 16), NSW Department of Primary Industries, Orange, accessed 8 November 2012:

http://www.dpi.nsw.gov.au/agriculture/livestock/animal-welfare/general/dogs-horses/horses/awfact16_

Jephcott, S. 2009 “Managing Horses in Feedlots” Chinchilla Veterinary Services, Chinchilla, accessed 8 November 2012:

<http://www.chinchillavet.com.au/ServicesInfo/Horses/HorsesinFeedlots/tabid/18861/Default.aspx>

McKiernan, W.A. 2005 “Horse Yards and Handling Facilities” NSW Department of Primary Industries, Agfact A6.7.1, second edition, accessed 8 November 2012:

<http://www.dpi.nsw.gov.au/agriculture/livestock/horses/management/general/yards>

MLA, 2012a, National Guidelines for Beef Cattle Feedlots in Australia. Meat & Livestock Australia, Sydney, NSW.

MLA, 2012b National Beef Cattle Feedlot Environmental Code of Practice. Meat & Livestock Australia, Sydney, NSW.



FEEDLOT DESIGN AND CONSTRUCTION

38. Fuel and gas storage

AUTHORS: Orla Keane and Rod Davis



Diesel tank with a good paint coating, free from rust and damage. A more reflective colour (silver or white) would be preferable.



Impervious bunding around fuel storage tanks must be large enough to contain the combined capacity of the tanks plus 20 minutes of fire-control water.



LPG tanks with bollard protection from potential vehicle impacts.

Introduction

Large quantities of fuels including diesel, petrol, LPG, natural gas and butane are used on feedlots and must be stored safely to protect against environmental harm and to provide a safe working environment. This section provides an overview of the requirements for fuel and gas storage. However, because there are many particular requirements, expert advice should be sought and can often be provided by the fuel supplier.

Design objectives

Suitable fuel and gas storage should

- protect against any environmental harm
- provide a safe working environment for people
- maintain the integrity of the fuel being stored
- provide adequate supply of fuel for operational requirements
- have adequate access for safe delivery of fuels
- protect against fire hazards.

Mandatory requirements

Compliance with

- National Guidelines for Beef Cattle Feedlots in Australia (MLA, 2012a).
- National Beef Cattle Feedlot Environmental Code of Practice (MLA, 2012b).
- relevant Commonwealth, state and local authority codes, regulations and relevant Australian standards as applicable to feedlot development. These include
 - Steel tanks for fuel storage need to meet AS 1692-2006 Steel tanks for flammable and combustible liquids. Most tanks used at feedlots fall under Category 2 of these standards: vertical or horizontal tanks of up to 2,500 L capacity, for above ground use, and intended for use on farms and other open space locations.
 - Storage of fuel on land that has an area exceeding 5 ha and is intended for agricultural, horticultural, floricultural or pastoral purposes, and not for resale, is considered a minor storage. Minor storage requirements are dealt with in AS 1940-2004 – *The storage and handling of flammable and combustible liquids*. While full compliance with this standard is not mandatory, if storage tanks are separated by at least 100 metres and each storage tank holds no more than 5000 litres of flammable liquids (petrol) and 10,000 litres of combustible liquids (diesel) compliance is recommended for safety reasons.
 - AS/NZS 1596-2008: The storage and handling of LP gas covers both cylinder and tank storage of LP gas. In many cases, minor storage will apply for cylinders that comply with section 2 of this standard.
 - AS / NZS 1200-2000: Pressure equipment includes the pressure vessel design code for LP gas tanks.

- AS 5601.1-2010: Gas installations – general installations specifies requirements for gas pipelines (under 200 kPa).
- AS / NZS 1869: 2012 – Hose and hose assemblies for liquefied petroleum gases (LP Gas), natural gas and town gas specifies requirements for hose and hose assemblies for LP gas.
- The Work Health and Safety Act (2011) (WHS Act) and the Work Health and Safety Regulations (2011) (WHS Regulations) address worker safety issues associated with fuel storage.

Design choices

Protection against environmental harm

The main environmental risk posed by fuel storage is the leakage or spillage of fuel contaminating soil and/or water. To guard against this risk, bunding or other methods of containment of any leakage or spillage from the storage should be provided. While bunding is not compulsory for minor storage on farms, it is strongly recommended and may be required if quantities exceed the minor storage thresholds or if there is a risk of environmental harm in the event of leakage or seepage. The limits for minor storages on open land are 5000 L for flammable liquids (petrol) and 10,000 L for combustible liquids (diesel).

For above ground fuel tanks, the containment must be able to hold the capacity of the largest tank plus the amount of fire-control water that would be discharged in 20 minutes. If two or more tanks operate as a single unit, the combined capacity of these should be used to calculate the bund capacity. The containment should be impervious so that it can hold a spill and allow for fuel recovery.

Bunds need to be structurally stable, including in the event of a fire. Earthen bunds need to be well compacted to minimise seepage. Moderately high bunds are preferred as this minimises the area of fuel burning in the event of a fire.

If earthen bunds are 1 m or more in height, they should have a flat top at least 600 mm wide. Any bund more than 1.5 m high must provide a means for safe and rapid entry and exit. Any pipe that passes through a bund must be designed to prevent excessive stresses as a result of settlement, or expansion in the event of fire exposure. The joint between the pipe and the bund must be sealed to prevent leakage.

The distance between the tank and the top inside edge of the bund should be at least half the height of the tank. Access for emergency vehicles should be provided around and between bunded areas.

Basic spill kits should be kept where minor spillage or leakage from the fuel tank could result in the contents flowing into a watercourse. Fuel suppliers can provide information on commercial spill kits.

Provision of a safe working environment

Above ground fuel tanks are often mounted on stands to provide for gravity feed. Safety hazards include the risk of the tank toppling or the tank support collapsing. The support structure for an above ground tank must have suitable, stable foundations considering



Four legs on support structure with braces close to their base, legs and bracing straight, in good condition and securely attached. Ladder sound and secure, all rungs present, suitable hand holds near ladder.



Feet pads above ground and secured to concrete pad with well-braced legs.



Fuel hose in good condition, with fuel filter and meter to record fuel usage.



Fittings, pumps and hoses – fuel dispenser hoses must be of an approved type for the fuel, with an internal bonding wire for dissipating any static electricity charge generated during dispensing.

the weight of the full tank. The legs of the support must have large enough pads or feet to distribute the weight of the full tank without undue ground settlement. The tank must be soundly attached to the support so that there is no risk of the tank falling off. If the legs of the support fit into a sleeve on the tank, they should be pinned or bolted into position. The structural integrity of the support is enhanced through bracing.

Risk to personnel falling applies mostly to drivers delivering fuel, and employees checking fuel levels and dispensing fuel.

Risks can be lowered by installing a bottom-loading facility, fitting a sight gauge or locating fuel tanks at ground level and dispensing fuel with a pump.

Where a fixed ladder is needed, it should meet the requirements of Australian Standard AS 1657. The ladder needs to be firmly attached to the tank, be at least 300 mm wide, have adequate handrails, provide a platform at the top, start within 300 mm of the ground, and be at an angle of 70–75 degrees. A worker should not need to leave the ladder or over-reach to access dip and fill points.

There is also a risk of the fuel igniting and the associated risk of tank explosion with any fuel storage vessel.

All fuel storage tanks should be constructed in accordance with the Australian Standard AS1692 Tanks for Flammable and Combustible Liquids.

Dispenser hoses must be approved for use with the applicable fuel, have an internal bonding wire that can dissipate static electricity generated during dispensing, and be fitted with an approved fuel dispensing nozzle with a trigger valve.

A lockable, steel isolation valve should be fitted between the tank outlet and the dispensing hose. Any pumps must be of a type approved for use with fuel.

All LP gas storage tanks and infrastructure must comply with AS/NZS 1596–2008. LP gas tanks must be made from steel and comply with the pressure vessel design code provided in the Australia / New Zealand standard AS/NZ 1200 Pressure Equipment.

Every opening through the shell of a gas tank must be fitted with a means of preventing accidental or uncontrolled releases. Piping must comply with the appropriate standard (AS 5601 or AS 4645).

LP gas pipelines must be clearly marked with printing, stencilling or labelling at critical locations (adjacent to connections, emergency shut-down systems and isolation valves) and/or by painting liquid lines in Raffia No. X31, vapour lines in Aqua No. B25 or pipelines white with tracer colour (as above) at the critical locations.

If unodourised LP gas is to be used, the tank must be fitted with a gas detector and an emergency shut-down system that operates if gas is detected. The gas detector should also set off an audible alarm if a leak is detected. In most cases, the gas tank(s) will be supplied and installed by the gas supplier who will be well versed in the statutory requirements for such installations.

Fit each fuel or gas tank with a suitable vent or relief valve. The vent must be sized taking into account changes in pressure resulting from filling, emptying, or atmospheric temperature change.

All fuel storage tanks must be clearly labelled with the contents of the tank. This labelling should be easily read from ground level. Prominent 'NO SMOKING OR OPEN FLAME' or equivalent signage is recommended near the outlet of all fuel storages.

Petrol and diesel storage tanks should be located at least 15 m and 8 m respectively from any ignition source. They should be at least 15 metres from the property boundary and any protected works (e.g. dwellings, workshop and accumulated combustible materials), 3 metres from combustible vegetation and 5 metres from overhead wires.

Sources of ignition are not permitted within the hazardous area around an LP gas tank and associated infrastructure. The distance between LP gas tanks and public places and railway lines, or protected places depends on the size of the tank. Refer to AS /NZS 1596 for more details.

Above ground LP gas storage tanks need to be at least 6 m from any other above ground tank, package store or filling area for flammable or combustible materials; at least 3 m from the top of a bund used to contain flammable liquids; and at least 2 m from the vent outlet of a flammable liquid storage. They must be separated from other LP gas tanks by at least the diameter of the largest tank.

Underground LP gas storage tanks must be at least 3 m from underground tanks used to store flammable and combustible liquids although this can be reduced to 1 m if a specifically designed, compatible corrosion protection system that caters for the area between the tanks is provided. Other separation distances also apply (see AS /NZS 1596).

Above ground LP gas tanks must be outside with free cross-ventilation around the tank. They must not be installed in, or above, a significant ground depression where a spill or leak could accumulate LP gas.

Consider the location of overhead powerlines when positioning the storage. LP gas tanks cannot be installed within the shadow area of an aerial power line (see Table 6.2 of AS / NZS 1596 for details).

All fuel storages should be secured against access by unauthorised persons. LP gas tanks and infrastructure must also be protected from possible impact by moving vehicles. Options could include

- 75 mm steel pipes filled with, and set into, concrete. These should be at least 1.5 m from the tank or infrastructure being protected, at least 1.2 m high (unless they are positioned 4 m or more from the item being protected when they can be 0.5 m high) and spaced no more than 1.3 m apart; or
- highway crash barriers at least 700 mm high, set into concrete or equivalent support, located 1.5 m from the item being protected; or
- fenced compounds with 1.8 m high chain link fencing complete with tension wires and 50 mm diameter steel posts set in concrete.



Fuel bowser with fuel-dispensing nozzle having a trigger valve mechanism, and product clearly identified.



Isolation valve on dispenser is kept turned off except when dispensing fuel. Rust on the tank and outlet pipe needs to be treated.



Rust – tanks should be protected against corrosion by a good paint coating.

Tank soundness

Tanks must be of sound construction and suitable for filling with petroleum products. This means that there are no signs of leaks, or major deformations of shape (cracks, dents). For tanks with supporting structures, these deformations will move the tank's centre of gravity and will also establish stress points where corrosion will occur more rapidly, or stress the supporting framework.

All fittings on the tank must be in good condition and free from leaks. If a dispensing hose and nozzle is fitted, it should have an isolation valve at the tank outlet.

There must be no corrosion that could materially affect the tank's integrity. As with supporting structures, rust can have a major impact on the soundness of a fuel tank. The degree of damage caused by rust is dependent on the thickness of the steel used in the tank's manufacture, and the depth of the rust has penetrated. AS1692 outlines the minimum thickness of plate used in tank construction with which current manufacturers of fuel tanks comply.

Areas at particular risk of rust damage are

- top of tanks, especially if they are cylindrical tanks mounted vertically (on end)
- underside of tanks
- fill point, outlet and drain plug
- welded seams
- surfaces and joints between the tank and the support structure.

Maintaining the integrity of the fuel being stored

Small particles, water, microbes (which may be present if water is) and the by-products of the fuel aging process can all reduce fuel quality and cause problems with equipment using the fuel.

A well fitting, fine filter on the inlet will prevent small particles from entering the tank. Avoid galvanised tanks as the zinc and zinc alloys may react with diesel to form particles. Microbial action can also produce particles.

To keep water out of the tank, install a desiccant breather to remove moisture and airborne debris from air drawn into the tank as fuel is removed. Turning over fuel frequently minimises moisture problems and microbes. Hence, tanks should be sized to meet the needs and contingency requirements of the feedlot. Minimising temperature extremes also minimises condensation (and microbial growth).

To maintain fuel quality and reduce losses, install fuel storages out of direct sunlight (but not under trees) and paint them a light colour if possible. Installing storage tanks on a slight gradient allows water and sediment to collection at the low end and be removed.

Provide adequate fuel supply

The required storage volume for each type of fuel depends on the equipment used on the feedlot and how frequently it can be delivered. Tanks need to be large enough to meet the needs and contingency requirements of the feedlot.

Delivery drivers are required to ascertain and document the liquid level before and after filling the tank. This means that the tank needs to be equipped with suitable measuring equipment which could be a

- mechanical level gauge
- dip stick, calibrated in litres; or
- sight glass with adjacent calibration in litres.

Any gauge needs to show the safe maximum fill level.

Provide adequate access for safe fuel delivery

Access to the tank must be safe for the fuel delivery vehicle. Providing turnarounds so that the delivery vehicle does not have to reverse to the site of the fuel tank will minimise the necessity for difficult or dangerous manoeuvring. Adequate area should be provided for turning and straightening near the fuel storage to prevent accidental contact while positioning the delivery vehicle close enough to fill the tanks. See *Section 13 – Access and internal roads* for further information.

The area between the delivery vehicle and the filling point of the fuel storage must have adequate clearway and should be free of all rubbish, obstacles, machinery or junk within 3 m of tank legs. The area beneath the fuel storage tank is not to be used as a storage area for equipment or obsolete machinery.

Tank signage

Tanks used for the storage of fuel and gas should have appropriate signage, including Hazchem signage when appropriate, 'No Smoking' warnings and identification of the product contained in the tank.



Fuel type identification and easily accessible fill point

Further reading

Standards Australia (2004). The storage and handling of flammable and combustible liquids. (AS 1940-2004). Sydney, NSW, Standards Australia.

National Road Transport Commission (2007). Transport of Dangerous Goods, AGPS, Canberra.

Standards Australia (1998). Steel tanks for flammable and combustible liquids. (AS 1692-2006). Sydney, NSW, Standards Australia.

Standards Australia (2008). Flammable and combustible liquids - Precaution against electrostatic ignition during tank vehicle loading. (AS: 4979-2008). Sydney, NSW, Standards Australia

Standards Australia/Standards New Zealand (2009). Natural Gas (NG) fuel systems for vehicle engines. (AS/NZS 2739:2009), Standards Australia International Ltd., Strathfield NSW and Standards New Zealand, Wellington.

Standards Australia/Standards New Zealand (2001). Fuel containers – portable plastic and metal. (AS/NZS 2906:2001), Standards Australia International Ltd., Strathfield NSW and Standards New Zealand, Wellington.

Standards Australia (1994). Safety Signs for the Occupational Environment. (AS 1319:1994). Sydney, NSW, Standards Australia.

Safe Work Australia (2011). Code of practice: Preparation of safety data sheets for hazardous chemicals.

Standards Australia (2008). Flammable and combustible liquids - Precaution against electrostatic ignition during tank vehicle loading. (AS: 4979-2008). Sydney, NSW, Standards Australia.

Standards Australia (2008). The design, installation and operation of underground petroleum storage systems. (AS 4897:2008). Sydney, NSW, Standards Australia.

Standards Australia (2010). Dangerous goods – Initial emergency response guide. HB 76:2010. Sydney, NSW., Standards Australia.

Standards Australia/Standards New Zealand (2001). Fuel containers – portable plastic and metal. (AS/NZS 2906:2001), Standards Australia International Ltd., Strathfield NSW and Standards New Zealand, Wellington.

Standards Australia/Standards New Zealand (2010). Safety, protective and occupational footwear - Guide to selection, care and use. (AS/NZS 2210.1:2010). Standards Australia International Ltd., Strathfield NSW and Standards New Zealand, Wellington, Standards Australia.

Standards Australia/Standards New Zealand (2000). Occupational Protective Gloves - Selection, Use and Maintenance. (AS/NZS 2161.1:2000). Standards Australia International Ltd., Strathfield NSW and Standards New Zealand, Wellington, Standards Australia/Standards New Zealand.

Safe Work Australia standards and codes of practice National standards and codes of practice for the safe storage and handling of hazardous substances and dangerous goods are used as model legislation by the states and territories, and are useful guidance material. The National Code of Practice for the preparation of MSDS provides guidance for suppliers of hazardous substances. WHS legislation also has requirements for matters such as employer/employee consultation, first aid and amenities.
<http://www.safeworkaustralia.gov.au/sites/SWA>



FEEDLOT DESIGN AND CONSTRUCTION

39. Agricultural and veterinary chemical storage

AUTHORS: Orla Keane and Peter Watts

Introduction

Agricultural and veterinary chemicals used in a feedlot must be stored in a way that maintains product integrity, prevents environmental harm and protects worker safety. Risks associated with agricultural and veterinary chemical storage include leakage, spills and fires; they also arise from accidents and spillage when opening containers and handling or mixing chemicals.

The exposure or physical risks to any person close to the incident may be high while environmental risks from escaping chemicals may be considerable. These risks can be controlled by reducing the likelihood of an incident occurring, and establishing emergency procedures to reduce its severity should it occur. Some chemicals are classified as dangerous goods and specific requirements apply if quantities stored are above certain limits.



Shipping containers make an excellent storage facility for chemicals. Note the drain at the front of the container and shower on the left.

Design objectives

A suitable agricultural and veterinary chemical storage area for 'minor storage' should

- be situated in a suitable location that provides a buffer to sensitive locations
- be structurally robust and secure
- maintain the integrity of the agricultural and veterinary chemicals in storage
- provide a safe working environment
- prevent unnecessary contact between livestock and agricultural and veterinary chemicals
- protect against any environmental harm
- provide adequate storage of agricultural and veterinary chemicals to meet practical needs.

Mandatory requirements

There are various mandatory requirements for agricultural and veterinary chemicals storage, summarised as follows.

- *Duty of care* under common law means that activities must be carried out in a safe manner so as not to cause harm or injury to the user, other people, animals or the environment. A breach of a duty of care may amount to negligence.
- Chemical storage must comply with the requirements of the Dangerous Goods Act (1998) and the Dangerous Goods Regulations (1998). These regulations detail the dangerous goods licensing exemption limits. The amount of a chemical that can be held in storage without licence (minor storage) depends on its classification.
- The standards for 'minor' storage cover quantities of chemicals up to 1000 litres or 1000 kilograms in total. For larger quantities, extra precautions are required to satisfy the Dangerous Goods Act (1998) and the Dangerous Goods (General) Regulations (1998).
- Storage facilities must meet Australian Standard (AS) 2507-1998 and be approved by Workplace Standards before a licence

is granted for dangerous goods. Generally, chemicals must be stored in a secure, dry and well-ventilated area out of direct sunlight. Some veterinary chemicals require refrigeration. Chemicals should not be stored with fertilisers, seeds, food, stock feed or personal protective equipment. Containers should be frequently checked for leaks or signs of deterioration.

- The Workplace Health and Safety Regulations require that a register of hazardous substances be kept and maintained at the storage area. This must be readily available to any employee who may be exposed to the hazardous substance.
- The Poisons Act (1997) requires clear 'Poison' labelling and secure storage of all dangerous poisons.
- The storage for restricted veterinary chemicals (listed in Schedule 4 of the Poisons Act (1971)) must not be accessible by the public. Veterinary chemicals must also be kept in a separate area and apart from other goods that are suitable for human or animal consumption.
- The Work Health and Safety Act (2011) and the Work Health and Safety Regulations (2011) include requirements for chemical storage and use.
- There are variations across Australian states in the extent to which agricultural and veterinary chemicals are classified as a waste; for example, in New South Wales (hazardous waste), Queensland (regulated waste) and South Australia (listed waste).
- Local Authority approval may be needed for bunds used to contain chemicals in the event of a spill.
- Compliance with the National Feedlot Accreditation Scheme (AUS-MEAT, 2014) as applicable to agricultural and veterinary chemical storage.
- Compliance with the National Guidelines for Beef Cattle Feedlots in Australia (MLA, 2012a) as applicable to agricultural and veterinary chemical storage.
- Compliance with the National Beef Cattle Feedlot Environmental Code of Practice (MLA, 2012b) as applicable to agricultural and veterinary chemical storage.

Technical requirements

A risk assessment should be conducted for all stored chemicals. The key hazards and risks are indicated by the dangerous goods classification on the label of the container.

For all chemicals, the following should be considered

- the quantity of chemical to be stored and the type of containers (i.e. in packages or in bulk)
- the duration of storage
- the dangerous goods class, packing group and other characteristics of the chemicals with respect to toxicity, stability and compatibility (see the Material Safety Data Sheet (MSDS) or supplier)
- the separation of chemicals from other classes of dangerous goods
- spillage control (for liquids)



Cool storage for veterinary chemicals



Large cool room storage for veterinary chemicals



Appropriate signage should be clearly visible on the exterior of the storage facility.

- fire rating of the storage structure and walls
- ventilation
- emergency procedures and equipment needed in the store (consult the MSDS for information on fires and other emergencies)
- the need for control of potential ignition and heat sources
- separation from other stores of chemicals, fuels or combustible materials
- separation distances from other activities and accommodation.

Separation distances, the isolation of spills and suitable emergency procedures are important control measures even when small quantities of chemicals are stored for short periods.

Site selection

Chemical storages should be located

- in a practical location e.g. veterinary chemical storages could be provided at or near the induction and hospital areas
- in a clear, open area
- at least 15m from the property boundary
- at least 5m from watercourses, dams, drainage or sewage lines
- at least 3m from stored flammable liquids
- well above the maximum flood level
- near a clean and reliable water supply to allow for tank filling and emergency use.

Structural requirements

The chemical storage should be a designated lockable area that is not used for any other purpose. It may be

- a roofed outdoor area with a security fence
- a freestanding, roofed building
- a building attached to another building
- a room, enclosure or area within a building.

It must be a physically robust, fire-resistant structure with a floor of non-slip, sealed concrete or other easily cleaned, impermeable material. It should provide clear access and outward opening doors or gates, be well ventilated and have good light for reading labels. A clean and reliable water supply should be close to the chemical storage for product mixing and emergency use.

Separate storage areas nearby should be provided for

- first aid kit
- personal protective equipment (PPE) (e.g. overalls, waterproof pants and coat, gumboots, rubber gloves, respirator gloves, face shield, PVC apron, hat)
- mop-up materials (e.g. sand, soil or dryorb and hydrated lime)
- cleanup equipment (e.g. shovels, brooms, heavy duty bags, bins)
- dry powder extinguisher.
- An outside shower and eye wash can be installed for personnel to wash off major spills of toxic chemicals.



Emergency shower and hand basin located outside of chemical store.

Protecting the environment

Spills and leaks of chemicals from containers pose an environmental risk. The risk can be mitigated by providing a roof and impervious floor, and bunding or walls to prevent seepage and contain spills. The contained area may confine the whole storage facility or just the part where chemicals are physically kept (e.g. exclude walkways).

The bunded area should be able to hold at least 25% of the total volume of stored chemicals. For flammable liquids, the bunded area should have a capacity of at least 133% of the capacity of the largest container. More capacity will be needed if part of the bunded containment capacity will be displaced by the containers or storage infrastructure.

If an automatic fire sprinkler system is installed in/over the bunded area, the containment capacity should be increased by the volume of 20 minutes of sprinkler output, or up to 133% of the capacity of the largest container.

If chemicals are to be handled or mixed outside the storage, this should also occur in a bunded, impermeable area. The floor of the bunded area may slope so that spills accumulate up one end for ease of management and disposal.

The floor and walls of bunded areas should be built from materials impervious to the chemicals being stored. These should be of sufficient strength and structural integrity to ensure that the bund is unlikely to burst or leak in ordinary use. Reinforced concrete is recommended.

The chemical storage area needs to be structurally robust and vermin proof.

Maintaining product integrity

The storage facility should provide a cool, dry place for chemicals. It should have wall and floor insulation. Any shelving should be located on the coolest side of the storage and away from direct sunlight or radiant heating.

Different classes of chemicals should be stored separately. Liquids should be stored below dry chemicals.

Providing a safe working environment

The chemical storage must be kept locked when not in use. Signs on the entry should carry the following information:

- 'Chemical store – keep out – authorised staff only'
- 'No smoking or naked flames'

A 'No smoking' sign should also be placed inside, along with one indicating the location of the spill kit.

A first aid kit needs to be available near the chemical storage. Depending on the chemicals used, a shower and eye wash could also be considered. This should be located outside the chemical storage. The shower water supply must be able to provide at least 15 minutes of full water flow.

Material Safety Data Sheets (MSDS) must be kept for all chemicals in storage and in a space that is clearly visible and accessible to all trained employees.



Security - The chemical store must be kept locked to prevent unauthorised entry, with windows and vents designed to keep out children or others.



Clearly signed fire extinguishers on the outside of storage



Storing empty chemical containers.

Drums, other packages and containers marked 'returnable' should be stored securely until they can be returned to the supplier or sent to a drumMUSTER.

<http://www.drummuster.com.au/>



Inappropriate storage of chemicals in an unsecured shed.

Preventing chemical contact with livestock

To prevent livestock and animal contact with chemicals, the storage should have solid walls and/or security fencing and a roof.

Providing adequate storage to meet needs

The stores must provide enough space, and be of the right configuration, to store the chemicals used at the feedlot. Some chemicals such as scheduled poisons, veterinary chemicals and flammables, need to be segregated from other products. Ideally, liquid chemicals should be stored at ground level but otherwise underneath and separate from dry chemicals.

If shelving is used, it should be

- located on the coolest side of the storage and away from direct sunlight, electrical and heat sources
- sufficient to avoid stacking containers on top of each other and to allow ease of access
- sturdy and made of non-absorbent materials (e.g. plastic or metal).

A fridge may be needed to store some veterinary chemicals.

Quick tips

- Chemical storages should be situated in a practical location.
- Chemical storages should be designated, lockable areas that are not used for any other purpose.
- Chemical storages should provide a cool, dry, well-ventilated environment.
- Chemical storages should have impermeable flooring with bunding to contain spills and leaks.
- Separate storage areas should be provided nearby for first aid kit, PPE, mop up materials and equipment and a fire extinguisher.
- Consider storage needs when planning the design of the storage so there is enough space, and the right configuration, to store the chemicals that will be used. A fridge may be needed to store some veterinary chemicals.
- To provide a second level of containment in case of a spill, all chemical storage units should be located within the controlled drainage area of the feedlot.

Further reading

Coombs, R., 2003, Feedlot Health and Safety – Regulation and Compliance, Meat and Livestock Australia, Project number FLOT.405, Final Report, Sydney, NSW.

National Road Transport Commission (2007). Transport of Dangerous Goods, AGPS, Canberra.

Standards Australia (1994). Safety Signs for the Occupational Environment. (AS 1319:1994). Sydney, NSW, Standards Australia

Safe Work Australia (2011). Code of practice: Preparation of safety data sheets for hazardous chemicals.

Standards Australia (1998). The storage and handling of agricultural and veterinary chemicals. (AS 2507:1998). Sydney, NSW, Standards Australia.

Standards Australia (2005). The use of ventilation and air-conditioning in buildings - Ventilation design for indoor air contaminant control. (AS 1668.2:2001). Sydney, NSW, Standards Australia.

Standards Australia (2005). The Storage and Handling of Toxic Substances. (AS 4552:2005). Sydney, NSW, Standards Australia.

Standards Australia (2010). Dangerous goods – Initial emergency response guide. HB 76:2010. Sydney, NSW, Standards Australia.

Standards Australia/Standards New Zealand (1997). Protective clothing - Protection against liquid chemicals Test method: Resistance of materials to permeation by liquids. (AS/NZS 4503 part 1-3). Standards Australia International Ltd., Strathfield NSW and Standards New Zealand, Wellington, Standards Australia

Standards Australia/Standards New Zealand (2010). Safety, protective and occupational footwear - Guide to selection, care and use. (AS/NZS 2210.1:2010). Standards Australia International Ltd., Strathfield NSW and Standards New Zealand, Wellington, Standards Australia.

Standards Australia/Standards New Zealand (2000). Occupational Protective Gloves - Selection, Use and Maintenance. (AS/NZS 2161.1:2000). Standards Australia International Ltd., Strathfield NSW and Standards New Zealand, Wellington, Standards Australia/Standards New Zealand.

Meat & Livestock Australia (2005). Factsheet: Responsible use of veterinary chemicals. Livestock Production Assurance: Element 2. Sydney, NSW, Meat & Livestock Australia.

Safe Work Australia standards <http://www.safeworkaustralia.gov.au/sites/SWA>

MLA, 2012, National Guidelines for Beef Cattle Feedlots in Australia - 3rd Edition, Feedlot Industry Accreditation Committee (ed.), June 2012, Meat & Livestock Australia, Sydney, NSW.

MLA, 2012, National Beef Cattle Feedlot Environmental Code of Practice – 2nd Edition, Feedlot Industry Accreditation Committee (ed.), June 2012, Meat & Livestock Australia, Sydney, NSW.



FEEDLOT DESIGN AND CONSTRUCTION

40. Machinery workshops

AUTHORS: Rod Davis and Ross Stafford

Introduction

Any feedlot needs a properly designed and equipped workshop for the repair and maintenance of machinery and for light engineering. Part of the building may also serve as a store for spare parts and consumables.

The workshop is generally a rectangular shed with an entrance at one end – either open or with doors which provide shelter from the elements. Its design and construction will depend on the size and location of the feedlot.

Design objectives

Machinery workshops should be designed, constructed and maintained to

- have sufficient space for undercover accommodation of feedlot machinery during maintenance and repairs
- have functional space for maintenance and repair activities
- have well lit and well ventilated space for maintenance and repair activities
- have sufficient space for spare parts for the repair and maintenance of on-site machinery
- be compliant with respective state building codes and relevant Australian standards
- provide a safe working environment.

Mandatory requirements

The building elements such as concrete footings, floor slabs and steel structures should meet the structural provisions of the Building Code of Australia (BCA) and local building regulations, and be designed in accordance with the relevant Australian standards.

Design choices

Site selection

Site selection is often difficult when planning a workshop, but the site should be well drained to allow access to the shed at all times and be accessible to vehicles and other items of plant. Topography and soil type will impact on earthworks and the design of foundations; on some clay soils, road base may be needed to ensure access in wet weather.

Accessibility, proximity to the feedlot and on-site traffic management are also considerations when selecting a suitable workshop site. See *Section 2 – Feedlot site layout* for overall site layout.

Sufficient distance should be allowed from other existing buildings to allow for future expansion, reduce fire hazard and allow room for machinery manoeuvring and parking.

The workshop should be orientated so that the main entrance is away from prevailing weather. Where possible, locate large doors in end walls so that roof water does not fall inside the shed, or provide adequate gutters.



Machinery workshop at large feedlot with drive through design and external storage area for steel.

Floor plan

A workshop area may be added to an existing machinery storage building or a separate building constructed. An attached workshop may increase the fire potential of the machinery storage area, but having both areas combined in one building or close to each other is more convenient.

The workshop area required will depend on the size of the feedlot, the equipment to be maintained and repaired and the type of equipment to be used. Machines should be able to be moved easily into and out of the workshop.

The workshop should be able to accommodate the largest machine on the site with space to manoeuvre equipment inside the building if required. Service space around the perimeter of the machine should be at least two metres wide for manoeuvring lifting equipment (e.g. forklifts).

One or more work benches and a machinery area 1–1.2 m wide will be needed along the walls, along with room for storage of equipment, tools, spare parts and consumables (e.g. nuts and bolts) and some additional space for new tools and equipment.

The interior layout should be planned to provide maximum convenience for doing maintenance and repair work. For example, welding units (gas and electric) located immediately inside the access doors will allow their use inside or outside the building.

Location of personnel access doors will depend upon the choice of floor plan and on the type of construction.

Steel or timber construction

Australia is well serviced by companies that design and construct all types of farm buildings. Cost will depend on geographic location, source of supply, span and length of the building and the way in which the project is undertaken.

The shed frame may be made from steel, timber or a combination of these two materials. Timber may need to be protected from termite attack while poor construction or inadequate maintenance may lead to corrosion problems with steel. Galvanised steel sheeting is the most common and most economical form of cladding.

Steel framed sheds may use three types of construction – portal frame, structural steel frame and stud frame. The cladding and flashings are common to all types.

Portal frame

The basic principle is that all the purlins (both rafters and columns) consist of cold-rolled C section joined by fabricated brackets that bolt each assembly together. The main structure is called the portal frame (Figure 1). The roof and wall members are added once all the portal frames have been stood.

The span width of portal frame sheds can be limited by the length of roof cladding. Steel roof cladding is usually limited to 12 m lengths, which is the length that can be transported on a semi-trailer. Wider spans would require multiple roof sheets or roll forming on site.



A large machinery workshop with double sliding doors and entry from both ends



A large machinery workshop with an open side offering good access, good ventilation and natural lighting – but little protection from the weather.

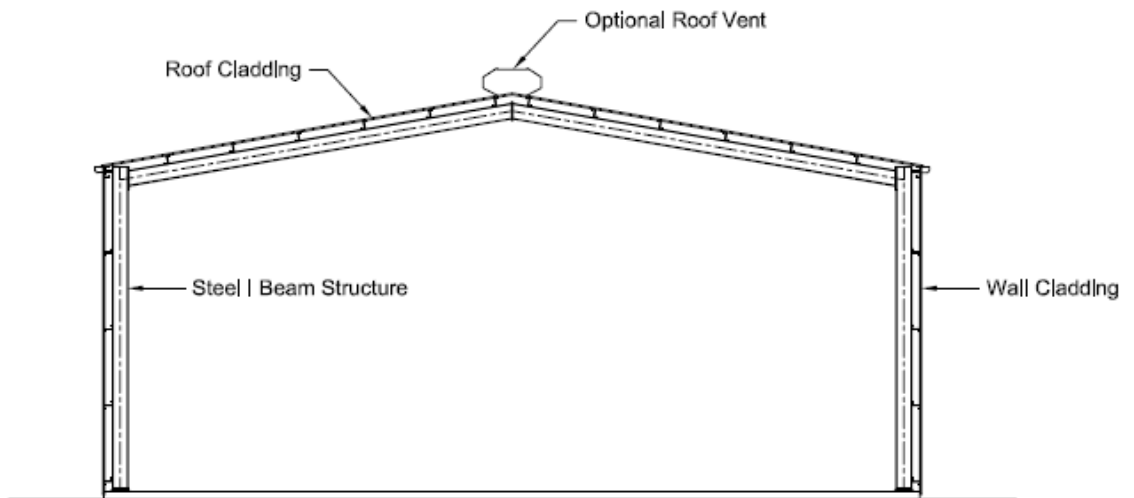

Figure 1. Typical cross section of a steel portal frame shed

Structural steel frame

With the structural steel frame, all the columns and rafters are from hot-rolled section such as H section, I beam, or C channels with welded cleats and joiners on all ends. The roof and wall members are normally the same as the portal frame (see Figure 2). The advantage of this type of design is that it allows larger spans, normally over 18 metres in width. The structural steel is heavy to transport but does allow faster erection and has an extremely high strength joining system.

As with portal frame sheds, the span width of structural steel sheds can be limited by the length of roof cladding. Spans greater than 12 m require multiple roof sheets or roll forming on site. Also a floor area greater than 500 m² requires additional services to comply with BCA requirements.

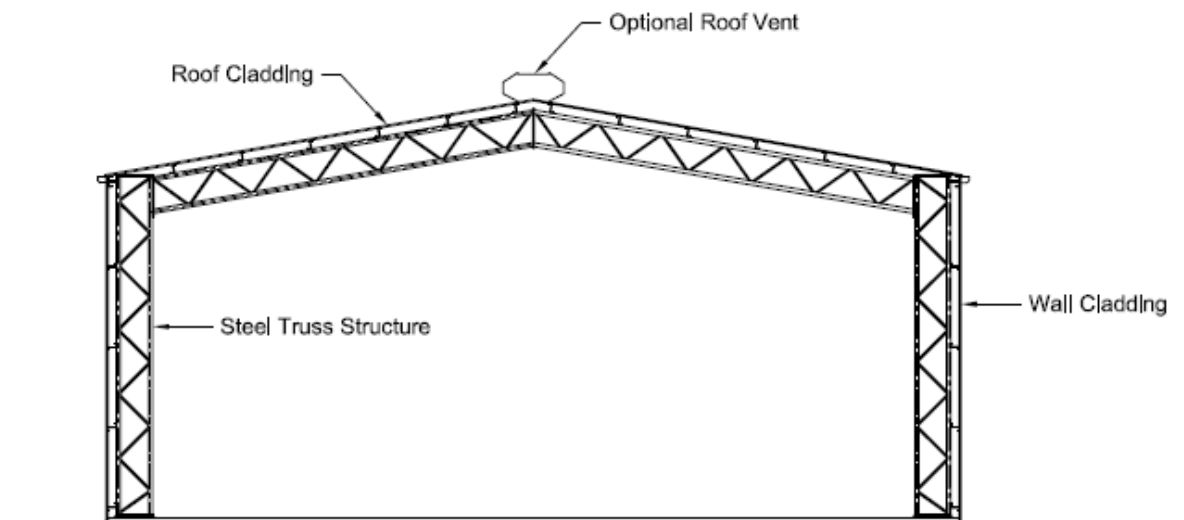

Figure 2. Typical cross section of a structural steel frame shed

Steel stud frame

This is identical to the steel stud framing used in housing and results in a very strong overall construction. The walls and trusses are all prefabricated in sections and simply stood on site and then clad. The advantage of this system is the ease of finishing the sheeting internally.

Structural design

Most shed companies provide a holistic design, structural design and manufacture service. Alternatively, structural design requirements may be obtained from a consulting structural engineer.

The structural design requirements include

- selection of appropriate member sizes and joint details
- erection of steelwork or concrete frameworks
- temporary fragility or instability of structure
- load-bearing requirements for overhead cranes
- stability and integrity of structure
- foundations/footing design for columns
- design of slab.

The design of the footings for a shed should take into account the bearing capacity of the soil and movement of soil due to wetting and drying.

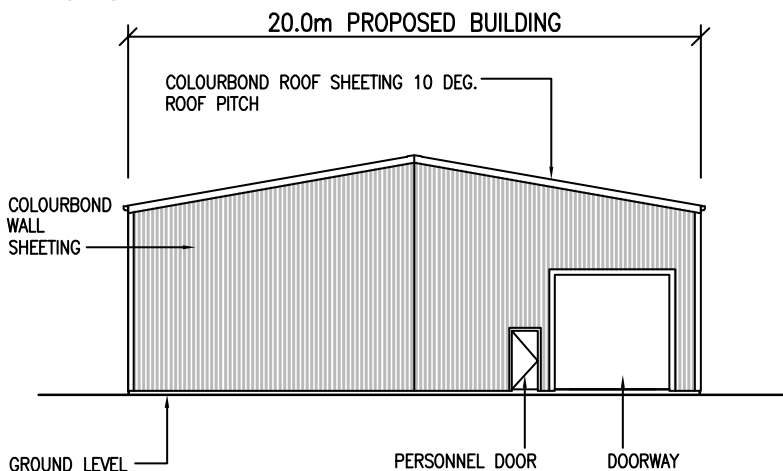

Figure 3. Typical cross section of a colourbond steel sheeted shed

Flooring

The floor of the workshop should be elevated at least 100–300 mm above the natural outside grade to provide good drainage and to stop water entering. The ground around the shed should be graded to channel water away.

A concrete floor in the workshop area will promote cleanliness, withstand the weight of machinery and provide a durable working surface. The floor should be sloped at a grade of 1% (1 mm per 100 mm) to the access doors for drainage.

Concrete shed floors are usually laid over a gravel-based subgrade before the shed frame is put up. Typically, the minimum thickness is 170 mm on a medium to good subgrade (200 mm on a poor subgrade) and is reinforced with square mesh.



Workshop with space for vehicle and machinery repairs, and with fluorescent and halogen strips for good lighting. Note the wall mounted swing-away jib boom for welder on the left.

Doors

The height and width of access doors should be 600 mm wider and 150 mm higher than the largest machine on the site.

Where practical, large access doors should be located on the end walls. One machinery access door may be adequate, but having doors in both the front and back will offer drive through ease in handling large machines.

There are various arrangements for workshop doors. These include sliding (bypass, bi-parting, single) hinged or roller. Each arrangement has its own advantages and disadvantages. The key considerations are space utilisation and cost.

Overhead roller type doors take less space and are easier to open than sliding doors, but are more costly.

Sliding and hinged doors require space to the sides of the opening and may limit access to the sides of the building. They are durable and cheaper.

At least one personnel door must be provided for safety and in accordance with relevant building codes.

Services

Electrical

Electric power will be required for various activities and services with generally single phase 10A and 15A outlets and 32A 3-phase outlets. The electrical service should have some reserve capacity for future expansion.

Electrical installation must comply with the current electrical standards including all subsequent amendments, and all applicable regulations and bylaws of statutory authorities. Work not covered by the requirements of statutory authorities must comply with the latest edition of the appropriate publication from the Standards Australia.

Lighting

It is impractical to install enough windows to provide sufficient light for working. Clear polycarbonate sheeting may be installed on the roof but degrades over time and is prone to damage from hail. Irrespective of windows, the primary source of light should be artificial.

The positioning and illumination level should be sufficient to eliminate shadowing and allow activities to be completed safely.

The following Australian Standards provide guidance on minimum illumination levels.

- AS1680.1-2006, 'Interior and workplace lighting – general principles and recommendations'
- AS/NZS 1680.2 series, 'Interior and workplace lighting – specific applications'

Ventilation

Workshops should be naturally or artificially ventilated. Gases and fumes from various activities need to be removed from a safety perspective. Exhaust fans may be installed for rapid air removal. Windows provide some natural ventilation and entrance of fresh air when exhaust fans are operating.

Essential safety measures

The Building Code of Australia (BCA) outlines the essential safety measures that apply to the various classes of buildings defined by the BCA. Refer to *Section 26 – Office and amenities*.

Machinery buildings would be classed as Class 10a (a non-habitable building or shed) according to the BCA. The essential safety requirements are stipulated in the Building Code of Australia, respective State Building Fire Safety Regulations and the relevant Australian Standards.

For example, a fire hydrant system or fire hose reels are not required in a building having a total floor area of less than 500 m². For Class 10 buildings, no point on the workshop floor must be more than 20 m from an exit, or a point from which travel in different directions to two exits is available, in which case the maximum distance to one of those exits must not exceed 40 m.

Hence, a workshop of 20 m by 24 m (Figure 4) complies with the BCA requirements for floor area and travel distance and no fire hydrant and hose reel system is required.

Portable fire extinguishers and electrical isolation of machinery are the bare minimum provision for a machinery workshop.



Australian Standard AS4084-2012 sets out the minimum requirements for steel storage and pallet racking systems.

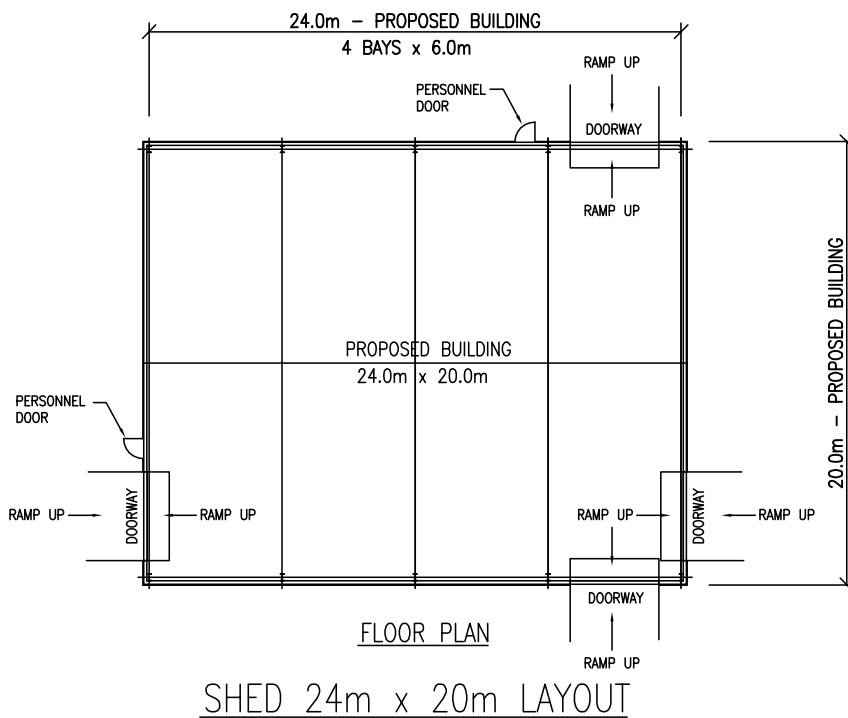

Figure 4. Class 10 buildings have a floor area of less than 500 m²

Hoists

A hoist should never be attached to the roof trusses since this would place an unsafe concentrated load on that portion of the building. A chain hoist should be attached to a portable beam supported at both ends with A-frames on casters. Alternatively it could be attached to a steel beam across the width of the workshop with the beam separately supported at each wall as a permanent part of the building. A permanent steel beam support is less versatile than a mobile A-frame unit.

Vehicle lift hoists

Vehicle lift hoists are an alternative to inspection pits for inspecting the undercarriage of vehicles, but they do need constant maintenance. With lift hoists, it is easier to walk to other parts of the workshop for tools but work cannot also be done above the vehicle when it is raised. Hoists are safer for servicing petrol vehicles because of fumes and the ability to escape in the event of fire.

In a feedlot workshop, a heavy truck lift needed to service the size of vehicles operating (trucks, tractors, earthmoving machinery) would be extremely expensive. As the number of vehicles to be serviced is low, an inspection pit offers a more practical and cost effective solution.

Inspection pits

Inspection pits are commonly used to inspect the underside and suspension of vehicles, to replace oil and filters and for servicing and minor repairs.

From a safety perspective, inspection pits are preferred for servicing diesel vehicles and vehicles with air bag suspension but not for petrol vehicles.

Inspection pits require safe means of entry and exit, usually stairways. At least one fixed entry/exit point should be provided with a separate means of escape where a risk assessment identifies the need e.g. where escape from the pit may be blocked by the parked vehicle or long pits. The surface around the inspection pit should be slip-resistant.

Typically inspection pits are along the workshop bay. The depth of the inspection pit is optional but its width depends on the vehicles to be serviced. The width is about 150–200 mm on each side less that the width between the vehicle tyres.

Inspection pits provide a safe working environment but they do present particular hazards. They are a common cause of accidents, not only to those unfamiliar with the premises but also to staff who momentarily forget the presence of an unfenced pit, or who slip or trip into them. Inspection pit edges should be painted so that the pit opening can be clearly seen. Temporary fencing needs to be provided when the pit is not in use, or a steel or wooden cover put in place.

Prefabricated steel inspection pits are also available.



Inspection pit with stairs for access. Pit should have temporary fencing when not in use.



Access to pits should comply with the relevant WHS requirements, with fixed handrails.

Signage

Machinery workshops should have appropriate signage, including

- Personal protection equipment to be worn – eye or hearing protection and footwear
- Evacuation procedure
- Emergency assembly point
- Emergency contact details
- No smoking
- Flammable gas
- First Aid station

Waste management

Wastes generated at machinery workshops include regulated wastes (hydrocarbon waste such as oils and tyres, solvents and batteries), general waste (damaged parts, air filters, hydraulic hoses, rags, cardboard and paper) and scrap steel. Some paint solvents are highly flammable.

The appropriate management and storage of all wastes, in particular regulated wastes, will prevent potential on site and off site environmental harm to livestock, land, surface water or groundwater.

Workshops should have the provision for storage, handling and spill containment equipment and materials for each category of waste generated.



Workshops should have signage and portable fire extinguishers.



Waste management – large oil drip trays (above) and aggregation tank (below)



Clear area for small vehicle repairs, but poor type of drip trays under the oil drums.



A cluttered workshop with insufficient bench space for small repairs.

Quick tips

- Sufficient distance should be allowed from existing buildings to allow for future expansion, to reduce fire hazard and allow room for manoeuvring and parking machinery.
- Consider space for manoeuvring repair equipment around the perimeter of the machine when sizing the workshop floor area.
- The correct structural design of a workshop should be carried out by a reputable manufacturer or by a structural engineer.
- Dimensions, member sizes or construction details must never be changed without the approval of appropriate authorities.
- Keep records of building approvals for future reference.
- Ensure adequate safety and fire protection measures.

Further reading

Local Authority Planning Scheme for local requirements for buildings.

Australian Building Codes Board (ABCB), 2013, Volumes One and Two of the National Construction Code of Australia.

Standards Australia (1998). Steel structures, AS 4100-1998, Sydney, NSW, Standards Australia.

Standards Australia (2002). Dead and live load combinations, AS/NZS 1170.1-2002, Sydney, NSW, Standards Australia.

Standards Australia (2005). Cold formed steel structures, AS/NZS 4600-2005, Sydney, NSW, Standards Australia.

Standards Australia (2005). Emergency Escape Lighting and Exit Signs for Building – Inspection and Maintenance, (AS 2293.2-2005), Sydney, NSW, Standards Australia.

Standards Australia (2009). Concrete construction (including reinforced and prestressed concrete), AS 3600-2009, Sydney, NSW, Standards Australia.

Standards Australia (2011). Masonry (including masonry-veneer, unreinforced masonry and reinforced masonry), AS 3700-2011, Sydney, NSW, Standards Australia.

Standards Australia (2011). Wind Loads, AS 1170.2-2011, Sydney, NSW, Standards Australia.

Standards Australia (2012). Routine service of fire protection systems and equipment, AS 1851-2012, Sydney, NSW, Standards Australia.

Standards Australia (2012), Steel Storage Racking, AS4084-2012 – Sydney, NSW, Standards Australia.

Standards Australia (2004), Cranes, hoists and winches – Guided storing and retrieving appliances, AS1418.6-2012 – Sydney, NSW, Standards Australia.



FEEDLOT DESIGN AND CONSTRUCTION

41. Cattle wash facilities

AUTHORS: Rod Davis and Peter Watts

Introduction

Humans can become ill from meat products contaminated by bacteria such as *Salmonella*, *Campylobacter* and *E. coli*. Animals carry these microorganisms within their intestinal tracts and excrete them in faeces. Meat may be contaminated if faecal material is transferred to the meat during the processing phase.

Reducing the manure and dirt on the hides of cattle being presented for slaughter lowers the risk of meat contamination when slaughtermen remove the hide, and most meat processing establishments require that the hides of cattle are visibly clean before slaughter. Dags are accumulated balls of manure and soil that adhere to the coat or hair of cattle, and are most prevalent on the brisket, underbelly, tail and sides (ribs, flank).

The main factors affecting the accumulation of dags are weather, pen conditions and the length of hair on the animal.

Abattoir requirements for cattle cleanliness as specified by AQIS are increasing and this puts pressure on producers to deliver cattle to abattoirs with minimal hide contamination. A number of abattoirs and feedlots have constructed on-site cattle wash facilities for the pre-washing of cattle for mud and dirt removal before pre-slaughter washing.



Mud and dags on the belly and sides of cattle during prolonged wet pen conditions must be removed before slaughter.

Design objectives

A cattle wash should be designed and constructed to

- remove loose dirt and manure on cattle
- reduce the level of dags on cattle, particularly on the slaughter cutting lines
- allow safe and efficient movement of cattle
- provide for easy separation and removal of washed hair, manure and soil
- contain durable, non-clogging and non-rusting components
- minimise stress and injury to cattle
- provide a safe working environment for people
- maximise water use efficiency
- safely contain contaminated water.

Mandatory requirements

Compliance with

- National Guidelines for Beef Cattle Feedlots in Australia (MLA, 2012a)
- National Beef Cattle Feedlot Environmental Code of Practice (MLA, 2012b)
- Australian Quarantine and Inspection Service (AQIS) standards.

Design choices

Process design

Cattle washing systems can be automated or manual, or a combination of both. Washing typically involves soaking followed by high pressure washing and in some circumstances, waterless mechanical removal. During soaking, cattle are exposed to low pressure sprays in a soaking yard to soften dags, mud and dirt and to wash loose manure and dirt out of the coat. Cattle are then subjected to a period of high pressure washing which may be manual hosing with high pressure hoses or an automatic system or a combination of both.

The waterless removal of remaining dags involves mechanical means such as combing, shaving or clipping, usually performed manually.

Cattle are usually washed only in winter, and not every winter.

Location

As cattle are washed at the feedlot before dispatch for slaughter, the cattle wash facilities are usually integrated into dispatch facilities or adjacent to them. Factors influencing the location of the cattle wash include proximity to the production pens and dispatch facilities, water supply and drainage. Cattle wash facilities must be within the controlled drainage area.

Sections 2 – Site layout, 21 – Livestock handling and 10 – Pen and drainage systems outline design choices for receival and dispatch facilities within the overall feedlot layout, livestock handling and runoff control and storage systems. However, a cattle wash will introduce a more regular inflow of water into the runoff control and storage system, and this needs to be considered in the design. Drains from cattle washes stay wet when most cattle drains are dry.

Facility layout

The facility layout will vary with the type of cattle (e.g. large versus small cattle), number of animals to be handled, infrastructure constraints for redeveloped facilities and personal preferences on facility layout.

The design should accommodate all the operations to be performed, be safe, work effectively, and allow cattle to be cleaned as efficiently and economically as possible. Cattle flow through the cattle wash facility should be orderly so that cleaning operations will minimise stress on animals and operators.

Cattle wash facilities may include holding pens, forcing pens, races, catwalks, a restraint device, water delivery and drainage and sediment control systems, some of which may be incorporated with the receival, dispatch and processing facility.

The key design considerations for cattle wash facilities are

- process layout for cattle flow and handling
- type and number of cattle to be washed
- water supply, pumping, reticulation and pipework
- access to restraint facilities for waterless cleardown
- prevention of injuries to and minimise stress on cattle (e.g. non-slip flooring)



Soaking yard with overhead spray system that ensures water flows down the side of the animal's body.



Side by side soaking pens with above-floor pipework and an overhead spray system



Concrete floor draining from right to left with herringbone pattern across the yard. This yard has rubber sheeting on fences and uses RHS steel for water delivery, with nozzles protected by welded covers.

- safe conditions for operators such as protection from adverse temperatures, adequate lighting, access, catwalks, injury prevention and from exposure to spray drift
- sediment control and removal, drainage and recycling of waste wash water
- type of construction materials (steel, concrete) with respect to longevity.

The components of a cattle wash facility are described below.

Holding yard

The design and construction of holding yards for the cattle wash facility is similar to that of receipt and dispatch facilities. Design considerations are outlined in *Section 22 – Receipt and dispatch facilities*.

Soaking yard

Shape and size

As the soaking phase is the longest of the washing processes, the soaking area usually includes a number of yards, each holding the largest group of animals required for high pressure washing as a batch. A batch may be sized to transport vehicle deck sizes (see *Section 22*) or any other size as appropriate for ensuring operator safety during the cleaning processes.

Actual yard size is based on the preferred stocking density, with typically a minimum of 1.8 m² per animal.

Stocking rates should ensure that the full area of the soaking yards is used to improve water use efficiency.

Soaking yards are usually straight sided rectangular or herringbone rather than circular, as these are easier to construct, marry with adjoining pens, can be split into additional yards and incorporate pipework and drainage.

A straight sided soaking yard can be more easily built into an existing set of yards than a circular type.

The soaking yard must be designed so that cattle can be easily moved into it from the holding yard or forcing pens, and then easily moved out of it into the high pressure washing yards when required.

Flooring

The soaking pen surface should provide confident footing for the animals in all conditions, be easy to walk on and should not be slippery.

Floors need to be constructed of concrete for durability and with a non-slip finish in cattle and people traffic areas. Alternatives include heavy duty steel cattle mesh suspended on or above concrete, but these need satisfactory methods of cleaning.

A non-slip surface may be from fresh concrete with poured in place grooves or grooves cut in after the concrete has cured.

Grooves can be stamped in place by pressing, rolling or dragging some form into the wet cement to leave the desired pattern.

A typical pattern is squares ranging from 100 to 150 mm with 20–30 mm wide grooves between squares, or a herringbone pattern with grooves 20–30 mm wide and crossways every 100–125 mm.

The surface finish of the concrete floor (pattern and depth) will have an effect on the drainage of water off the yard surface area, with a herringbone-grooved pattern with the alleyways running parallel with yard fall helping drainage.

The concrete floor should be 125–150 mm thick and reinforced with a final strength of between 25 MPa and 32 MPa. 25 MPa concrete does not become slippery with wear from the action of the animal's feet but concrete at 32 MPa may become slippery as the animals hooves create a smooth, polished finish.

Concrete surfaces in existing or old worn yards may be cut to recreate the textured surface.

Slope

The degree of slope in a soaking yard may affect cattle flow and comfort as well as cleaning and drainage.

The design should allow gravity drainage of solids and wastewater to the sediment trap. Pens may be designed with a single slope (longitudinal only) or compound slope (longitudinal and cross slope).

Longitudinal slopes of about 3–4% (1:33 to 1:25) and a 1–2% (1:100–1:50) cross slope are desirable for cleaning, although floor patterns and placement of pipework may impede cross-fall drainage flow. The cross-slope is more appropriate for yards with no above floor restrictions and on sites that have a natural cross fall.

Any cross fall should increase to a greater slope at the bottom to direct the effluent to the sediment trap. Longitudinal slopes under 3% do not drain well if there is a buildup of mud/manure. Slopes greater than 4% lead to increased wear and the possibility of more slips and falls. The slope chosen depends on site topography. Lower slopes (<3%) are often chosen for flat sites to reduce earthworks.

Yards with two converging slopes and a centre drain minimise earthworks and make cleaning easier. Most of the manure falls close to the drain and is quick to wash away.

Drains should be positioned away from the entry of the high pressure washing yard lest they impede cattle flow into the yard.

Kerbing

The perimeters of concrete soaking pens may be kerbed to prevent soil and effluent washing from pens into adjacent laneways, and to help direct waste wash water to the sediment trap. A concrete kerb a minimum of 150 mm above the surface level of the pen would be sufficient.

Fencing

Most fencing panels in soaking yards are made of steel. Corrosion-resistant material such as stainless steel may increase longevity of posts in fence lines, especially if using recycled water, but is expensive.

Steel products are available in various profiles (e.g. round pipe, oval pipe, square section (RHS)), and various surface finishes (painted steel, galvanised, stainless). Fencing is typically all steel construction



Concrete floor with herringbone pattern and above floor water pipework. Drainage flow is parallel with pipework.



Concrete floor with recessed pipework and mesh to provide non-slip surface



Gates provide access for cattle and equipment; hinged or overhead sliding gates are commonly used in a cattle wash.



Overhead gates are safer and more practical than hinged gates for operators in confined areas, but are more expensive to construct and require mechanical assistance to operate.

with no cables, as in production pen fencing styles. The design and construction of fencing for soaking pens is similar to that of processing facilities. Design considerations are outlined in *Section 23 – Cattle processing*.

Corrosion is a major problem and use of a more durable material and finish can help slow this.

The sides of the soaking yard are generally sheeted to prevent overspray onto adjacent areas, and to stop cattle from baulking at people or other cattle outside of the wash pen; they also reduce the wind chill factor and minimise cattle discomfort. Sheeting may be steel, rubber and high density polyethylene (HDPE). HDPE and rubber sheeting are available in various thicknesses with 8–10 mm HDPE being adequate. HDPE material is lighter than steel and, like rubber, is not prone to corrosion.

The fencing should have no protrusions or sharp edges in materials and finishes.

Gates

The design and construction of gates for soaking pens is similar to that of receival and dispatch facilities. The gates of the soaking yard are generally sheeted to prevent overspray onto adjacent areas and baulking. Design considerations are outlined in *Section 22 – Receival and dispatch facilities*. Gates between pens are usually sliding/overhead arrangement if there is no external alleyway.

Pipe system

Dags tend to hang from hair on the underbelly, brisket, tail and sides of the animal while dirt tends to be ingrained in the hair along the sides and around the rump and hocks of the animal. Hence, spray pipes are usually located on the floor or recessed into the floor of the wash yard, and may also be installed on the sides of the yard or overhead.

One or more hoses may also be required for manual cleandown in soaking pens.

Location of pipes

The pipe network is placed along the floor. Side-mounted sprays are effective in long narrow pens but are not usually in larger (square shaped) yards as their range is limited. Pipework on the sides of the yards is attached to the fence panels by saddles or U bolts at a height of 600–700 mm above the floor. Piping may also be placed along the top of the fence or over the pen depending on preference.

Exposed pipework should not cause any injuries to cattle. Water pipes may be recessed into the yard floor or installed on top of it.

Pipes recessed into the floor of the yard

Water pipes recessed into the floor are laid in a channel and covered by a grate or false floor so that the grate and spray nozzles are flush with the floor of the yard. Various prefabricated trench grating products incorporate a grated concrete surround that can be encased into the floor for ease of construction.

Recessed pipes protect the nozzles from damage, minimise hoof injury to cattle, provide obstacle-free drainage and cleaning of the yard with a bobcat or similar machinery with a flat-edged bucket.

Recessed pipes have to be installed at the time of construction and are more expensive than installing pipes on top of the floor.

Pipes on the yard floor

This system is easy to install for new or existing facilities with the pipes generally attached to the floor with saddle clamps. Pipes laid on top of the floor may trap sediment (e.g. rocks and manure), obstruct drainage and cleaning equipment and pose a tripping hazard for animals. Rows of above ground piping should not be connected together at the drain end of the pen.

Pipe spacing will depend on the spray nozzle/jet system used but should be distributed across the floor so that all animals in the wash yard are wet by the spray nozzles.

Capping the end of pipes allows the pipe to be opened and flushed to remove any blockages.

Size

Delivery pipes should not be less than 75 mm.

Spray system

As most manure is on the belly area, sprays are generally located on the floor and spray upwards.

The spray system used in soaking pens can include

- Low pressure spray – high volume/low pressure rates over an extended period (e.g. 1–2 hours) to fully wet the animals and penetrate the dirt and dags.
- Medium pressure spray – low volume/ high pressure over a shorter period (e.g. 30 mins to 1 hour) to impact the hide and soften the dirt and dags.

The spray system can be a simple design formed by drilling a series of holes in the pipe or installing spray nozzles.

The hole type nozzle costs little with a series of holes in an arc around the top of the pipe to create a fan pattern. Unless the hole is extremely small, the water tends to shoot out like a tiny fire nozzle (not misted) delivering too much water. More importantly, there is little uniformity of flow when using a simple hole e.g. in a long pipe with drilled holes, the holes nearest the water source will have a larger water flow from them than those at the far end.

Tiny holes are easily clogged by small stones or mud which can be trodden into the hole during washing, or by hard water or by impurities in open storage water.

Nozzles inserted in the delivery pipe distribute the water more evenly over a given spray pattern. A full cone nozzle is recommended over flat fan or hollow cone designs; a cone angle of 120° will provide good coverage over a circular area. Spray nozzles of large aperture will provide thorough overall wetting of cattle of all ages, sizes and breeds. The disadvantage is cost and the fact that the nozzles also stand exposed from pipes (some form of protection is required).

Running and maintaining spray nozzles is technically more demanding than holes in the pipe. The nozzles have to be regularly removed and cleaned, and they must be correctly adjusted to have



Above ground pipes can restrict drainage flow and trap manure. Nozzles can become clogged with manure.



Above ground pipes may restrict the flow of water to the drainage pit.



Holes drilled in pipes create a quick and cost effective spray system.



Spray nozzles need protection from the hooves of animals.



Soaking yard covered with shade cloth which redirects the spray water back down over the top of the animals

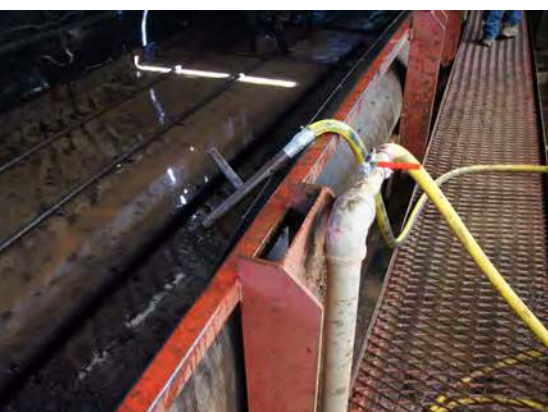

Adjacent catwalk with high pressure hose and nozzle

the right pressure and ensure correct coverage. Nozzles can bruise hooves, and damage hide and carcass if an animal falls.

The spray from the nozzles should be directed inwards and upwards so that the point of intersection of the sprays is at a height of between 600 mm and 700 mm above the floor.

Pipe material

Galvanised steel pipe is usually used for spray system pipework. Stainless steel will increase longevity if using recycled water, but the cost may be prohibitive. Plastic pipes can be crushed by cattle hooves.

Drainage

Pipes, drop pits or gutter drains are used to drain soaking yards. The water may be directed to a sediment trap before discharge to the drainage system. See *Section 11 – Sedimentation removal systems* for further information on design and construction of sedimentation systems.

The most practical drains are open concrete ditches sized for the volume and flow rates of the water used during soaking. Square concrete ditches should be constructed slightly wider than the width of a shovel for easy cleaning.

Drain material

Sewer quality PVC is best for underground drainage pipes, having a smooth interior, resistance to acid attack and being easy to install.

Drain slope

A slope of less than 1.5% may have insufficient flow velocity to flush material causing manure and other solid particles to lodge in the pipe.

Drain size

The recommended diameter for main drainage pipes is 200–300 mm with individual drainage pipes of at least 150 mm.

Pumps

The size of the water pump required by the cattle wash facility involves calculating pipe size, length of pipe runs, number and type of fittings and the number of takeoffs. Pumps for the soaking yards should be high volume and low pressure and vice versa for the high pressure yards.

There are numerous pumps and systems suppliers that offer a design and construct service.

Yard cover

The soaking yard may be covered with a shade cloth type material to create a misty environment. The water sprays hitting the shade cloth are directed down onto the backs of the animals. A canopy captures overspray and helps moisten cattle from above.

High pressure yard

High pressure washing may be done by manual hosing or with a fixed spray system or a combination of both. After soaking, the cattle are manually hosed with high pressure hoses, or yarded into a pen fitted with floor and side sprays delivering water at high pressure/low volume.

Cattle may be washed first with fixed sprays and then manually with a high pressure hose.

The target areas are the brisket, underbelly and inside of the hind legs in the flank region. These areas of the body, whilst often the dirtiest, are also along cutting lines where the hide is opened up or handled during slaughter.

Care needs to be taken when using a high pressure hose to avoid bruising and stress to the animal.

Shape and size

The shape and size of the high pressure yard will depend on the batch size to be washed and the method of washing. Design principles from the soaking yard can be applied to the high pressure yard.

Both sides of high pressure pens are usually accessible to allow manual hosing so most designs are walk through with overhead slide gates.

For manual hosing, the pen design should be narrow, similar to a wide race, to allow access to all cattle from the side.

Flooring

The high pressure yard is usually at the same elevation as the soaking yard. However, some facilities have a raised platform race so that the cattle are above the hosing operators who are at ground level.

The design principles from the soaking yard can be applied to the high pressure yard.

Slope and kerbing

Design principles from the soaking yard can be applied to the high pressure yard.

Fencing

Design principles for fencing materials from the soaking yard can be applied to the high pressure yard. Sheetting may not extend the full depth of the panel if access is required through the fence for hose nozzles.

A catwalk is usually constructed and puts the operator at the right level to coax animals in the right direction and access for manual hosing. See *Section 23 – Cattle processing facility* for design and construction details for catwalks.

Gates

The design and construction of gates for high pressure pens is similar to that of receival and dispatch facilities. Design considerations are outlined in *Section 22 – Receival and dispatch facilities*. Gates between pens are usually sliding/overhead arrangement.

Pipe system

Design principles from the soaking yard can be applied to the high pressure yard, but risers or hydrants will need to be installed along the side of the yard for attaching hoses for use in manual hosing. Multiple short hoses (5–7 m) connected at convenient points are more useful than one long hose (>7 m) as long hoses become difficult to handle and heavy to drag.



Raising the high pressure race makes it easier for the operator to view and clean the animals' undersides.



Short hoses from multiple takeoff points are easier to handle than a single long hose. Note the tap on the nozzle for flow control.



Mesh sheeting on high pressure race offers the operator protection from the animal whilst washing.



Manual high pressure washing of an animal inside a crush



Comb for scraping mud and dags off cattle.

A tap should be installed at the nozzle end of the hose for flow control, rather than at the riser/supply end.

Hoses should be fitted with a swivel to allow free hose movement without imparting torque stresses to the connection assembly.

The hose should be 40–50 mm diameter with a nozzle of 20–25mm diameter.

A flow rate of 60–150 L/minute (1–2.5 L/sec) with a pressure of 100–250 kpa (1–2.5 bar) is recommended. Hosing at short distances with higher water pressures (10 bar) can inflict welts on the side of the animal that become visible only when the hide is removed.

Drainage

Soaking yard drainage design and construction principles can be applied to the design and construction of the high pressure yard.

Waterless removal

A final phase of the cleaning process typically involves removal of remaining dags by mechanical means such as combing, shaving or clipping. These operations are usually performed manually and can be risky for operators unless the animal is restrained.

In most cases, the animals are restrained in a crush. *Section 25 – Cattle crushes* provides information on crushes.

Drain yard

An area to temporarily hold washed cattle while they drip off following washing may form part of the cattle wash facility. This may be part of a holding pen, separate from or part of the cattle wash facility. A drain yard is not generally required, as most of the water will drip from the animals if they are held in the high pressure yard for 10–15 minutes after final washing.

A concrete-floored pen at the exit from the high pressure yard has the advantage of returning water to the drainage system if the floor of the draining pen is sloped back towards the cattle wash drainage system.

Design principles for a soaking yard can be applied to the drain yard.

If cattle are not dispatched to the abattoir immediately, they should be held in a pen with bedding (e.g. woodchips, straw) to prevent recontamination with dirt and manure.

Buildings

Cattle are washed mostly during winter months when pens have less opportunity to dry out. Cold temperatures during the washing season also raise issues with operator safety and welfare of the cattle. Some feedlots wash cattle at night when temperatures may be even colder.

A cattle wash facility must provide a safe working environment. This may include a shelter structure that offers some protection from the environment, in particular cold windy weather. *Section 24 – Buildings* provides information on buildings and structures for cattle handling facilities.

Water usage and recycling

Washing of cattle is the second highest user of water in feedlots in the months when it is undertaken. The volume of water used will depend on the amount of mud and dags on the cattle, the cleanliness standard, level or score required at the processing plant, the number of cattle washed and level of wastewater recycled.

Average annual water usage across seven feedlots between 2007 and 2009 ranged from 700 L to 2500 L/head. Large volumes of water were required in periods where prolonged wet weather had resulted in particularly dirty cattle.

Some lot feeders can recycle the cattle wash water, while other use treated effluent for cattle washing. Recycled wash water is mainly used for soaking; it could promote cross contamination, but clean water is then used for high pressure washing.

The introduction of a water treatment system can improve the quality of recycled water for cattle washing. Many water chemical and biological reactions are dependent on dissolved oxygen levels, and water containing a high organic content has low dissolved oxygen and high microbial contaminants.

A simple cost effective treatment system in use within Australia is ozone treatment. Ozone treatment is commercially used in the final step for production of potable water as well as an aid in the degradation of human sewage effluent.

The chemical action of ozone (O_3) is in the creation of highly reactive, oxygen-free radicals that facilitate oxidation reactions. The free radical oxygen is toxic to most waterborne organisms (i.e. protozoa, bacteria, many viruses), reacts with metals and increases water oxygen content.

No chemicals are used in the ozone water treatment so there are no residues. Increasing oxygen levels in water allows greater natural chemical reactions, increasing rate of penetration into dag material for a more rapid degradation or release from hair.

At one feedlot, recycled cattle wash water coliform count was reduced by 85% with the application of ozone treatment. There was also a notable reduction of holding pond odour.



Triple-bay trafficable sediment trap. Drainage water can be directed to other basins to allow sediment to dry out.

Quick tips

- Cattle wash yards are usually straight sided and rectangular or herringbone in shape, rather than circular.
- Herringbone floor patterns with the alleyways running parallel with yard fall drain better than square shaped patterns.
- A herringbone pattern with grooves 20–30 mm wide and crossways every 100–125 mm provides a non-slip surface.
- Laying pipework on top of the yard floor is cheaper but may affect drainage and retain sediment against the pipes. Spray nozzles and/or animal hooves may also get damaged.
- Drilling a series of holes in the pipe provides a cheap spray system but less uniform water coverage.
- Washing cattle can consume a large amount of water.
- Recycling cattle wash water reduces the total clean water requirement for washing but could create safety issues from the high microbial contaminant loading in the effluent.
- Manual removal of dags by mechanical means such as combing and clipping is dangerous to operators unless the animal is restrained.

Further reading

Bell, R.G. (1997) Distribution and sources of microbial contamination on beef carcasses. *Journal of Applied Microbiology* 82: 292-300.

Bosilevac, J.M., Arthur, T.M., Wheeler, T.L., Shackelford, S.D., Rossman, M., Reagan, J.O., Koohmaraie, M. (2004a) Prevalence of *Escherichia coli* O157 and levels of aerobic bacteria and *Enterobacteriaceae* are reduced when hides are washed and treated with cetylpyridinium chloride at a commercial beef processing plant. *Journal of Food Protection* 67: 646-650.

Bosilevac, J.M., Nou, X., Osborne, M.S., Allen, D.M., Koohmaraie, M. (2005) Development and evaluation of an on-line hide decontamination procedure for use in a commercial beef processing plant. *Journal of Food Protection* 68: 265-272.

Byrne, C.M., Bolton, D.J., Sheridan, J.J., McDowell, D.A., Blair, I.S. (2000) the effects of preslaughter washing on the reduction of *Escherichia coli* O157:H7 transfer from cattle hides to carcasses during slaughter. *Letters in Applied Microbiology* 30: 142-145.

Greenwood, P., House, J. and Fell, L., 1998, Welfare Assessment of Cattle Cleaning Techniques, Final Report FLOT.303, Meat & Livestock Australia Ltd, Sydney.

Haines, H., Bobbitt, J., Simons, J., Rowland, D. and Coates, K., 2000, A review of process interventions aimed at reducing contamination of cattle carcasses, Final Report FLOT.213, Meat & Livestock Australia Ltd, Sydney.

Koohmaraie, M., Arthur, T.M., Bosilevac, J.M., Guerini, M., Shackelford, S.D. and Wheeler, T.L. (2005) Post-harvest interventions to reduce/eliminate pathogens in beef. *Meat Science* 71: 79-91.

Meat & Livestock Australia, 2001, De-Dagging, Factsheet CO-003. Meat & Livestock Australia, Sydney, NSW.

Nou, X., Rivera-Betancourt, M., Bosilevac, J.M., Wheeler, T.L., Shackelford, S.D., Gwartney, B.L., Reagan, J.O., Koohmaraie, M. (2003) Effect of chemical dehairing on the prevalence of *Escherichia coli* O157:H7 and the levels of aerobic bacteria and *Enterobacteriaceae* on carcasses in a commercial beef processing plant. *Journal of Food Protection* 66: 2005-2009.

Tucker, R.W., Gernjak, W., Davis, R.J., Scobie, M.J., Watts, P.J., Trigger, R.Z., Poad, G.D., Okeefe, M.F. and Bonner, S.L., 2010, Treatment Technologies for Feedlot Effluent Re-use, Project B.FLT.0348 Final Report, Meat & Livestock Australia, Sydney, NSW.

Tucker, R.W., and Klepper, K. 2005, *Review of on-farm food safety best practice*, Project PRMS.075 Final Report, Meat & Livestock Australia, Sydney, NSW.

Rowland, D., Phillips, M., and Coates, K., 1999, Assessment of Cleaning Systems for Cattle, Final Report FLOT.302, Meat & Livestock Australia Ltd, Sydney.

Slattery, B., Davis, J., and Carmody, B., 2005, Use of Enzymes for removing feedlot dags from the Live Animal, Final Report FLOT.214, Meat & Livestock Australia Ltd, Sydney.

Wescombe, G.L.J., 1994, Cattle Cleaning, Meat Research Report, 3/94, Meat Research Corporation.

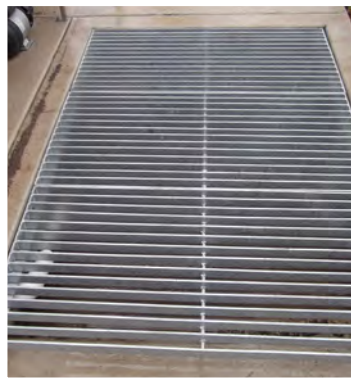

FEEDLOT DESIGN AND CONSTRUCTION

42. Vehicle washdown

AUTHORS: Rod Davis and Ross Stafford

Introduction

Vehicle and machinery hygiene is important for biosecurity, maintaining operational efficiency, maintaining aesthetic appearance and facilitating mechanical servicing.

Cleandown facilities vary in design, layout, functionality and operation depending on the type of vehicles, mobile plant and machinery that may require cleaning. These may include front end loaders, skid steers or bobcats, excavators, feed trucks, manure cartage and spreader trucks, tractors and tillage equipment and livestock transport vehicles.

Design objectives

The design objectives of a vehicle or machinery cleandown facility are to

- provide the required level of cleaning of mobile equipment for biosecurity, prolonging working life, aesthetic and/or mechanical servicing
- accommodate a range of vehicle, mobile plant and equipment types and configurations
- ensure collection of solid and liquid wastes
- minimise the release of contaminants to the environment
- provide contingency disposal options in case of system failure
- provide a safe working environment for people
- reduce the risk of regional or farm level spread of biosecurity hazards.

Mandatory requirements

Mandatory requirements for the design of feedlot vehicle cleandown facilities relate to minimising the release of contaminants to the environment and the provision of a safe working environment.

The washdown facility must comply with

- National Guidelines for Beef Cattle Feedlots in Australia (MLA, 2012a)
- National Beef Cattle Feedlot Environmental Code of Practice (MLA, 2012b)
- Work Health and Safety Act 2011 (WHS Act).
- Commonwealth, state and local authority codes, regulations and relevant Australian standards as applicable to feedlot development.

The installation of electrical services must comply with the current standards and with the requirements of the Supply Authority Services Rules and all applicable regulations and by-laws of statutory authorities. Other electrical work shall comply with the latest edition of the appropriate publication from the Standards Association of Australia. In some jurisdictions, the building elements such as concrete footings, floor slabs and steel structures may need to achieve the structural provisions of the Building Code of Australia (BCA). See *Section 26 – Office and amenities* and *Section 40 – Machinery workshops* for further information on structural design criteria.

Technical data

All vehicle cleandown facilities should incorporate the following functional elements

- building structures
- cleandown area
- stormwater management system
- solid waste management system
- liquid waste management system
- utilities – mechanical, electrical, hydraulic supply and services
- cleandown systems e.g. water, air, vacuum.

Design should integrate these systems so that the performance objectives are met with the least interference between elements. The design may also incorporate and utilise elements of the site layout rather than be a discrete stand alone system.

Building structures – enclosures for pumping equipment, control systems, cleandown equipment.

Cleandown area – suitably sized impervious setdown area/s for cleaning vehicles

Stormwater management system – stormwater exclusion features

Solid waste system – sedimentation system and solid waste storage/stockpile areas

Liquid waste system – drains, sedimentation system, holding ponds, oil/water separation if required

Utilities – required electrical, mechanical and hydraulic services

Cleandown system – provision of water, air or vacuum and associated pumps, pipelines and components. This may also include elevated platforms for personnel to safely access the top of vehicles to be cleaned.

A range of technical data is required before a layout can be proposed.

Design choices

When designing a vehicle and/or machinery cleandown facility, several design criteria will influence the overall layout.

Data requirements

Site plans– aerial photographs, topographic plans, site layout

Elevation data – site-specific elevation data – see *Section 7 – Site investigations*

Soils – site-specific geotechnical parameters for concrete footing, slab design and liquid waste management systems

Vehicle data – geometry (length, width, height) and weight of vehicles, mobile plant and machinery

Services – electrical power, water supply, water pressure and air pressure requirements

Accessibility – traffic flow, site layout – see *Section 2 – Feedlot site layout* and *Section 13 – Access and internal roads*.



Drive-through design with platform along full length of washdown pad. Wastewater drains to feedlot drainage system.



Concrete pad with suitable length and width for most feedlot vehicles, kerbed pad, adequate slope on pad and suitable wastewater collection system.



Concrete pad of suitable length and width for semi-trailers; 4% downslope provides excellent self-cleaning and drainage.

Design

Primary function

The primary function influences the overall design. For example, a facility which primarily cleans down livestock transport vehicles for biosecurity will have different design requirements to one for cleaning down only feedlot vehicles for vehicle maintenance.

Configuration

Design considerations include

- drive in-reverse out versus drive-through
- washdown system – manual or fixed overbody/underbody sprays, or both
- vehicle flow paths at the site
- bunding
- wastewater/sediment system
- underbody access – ramps etc or overbody access platforms.

Washdown area – material

Constructed to accommodate the weight and dimensions of the vehicles and/or machinery to be cleaned. The washdown area surface needs to be impervious, smooth, durable and easily cleaned. Concrete is the most common material used.

Typically, a minimum thickness of 150 mm slab on grade and edge thickening will be required.

Washdown area – size

Length and width of the washdown area is based on the dimensions of the largest vehicle and/or machinery to be cleaned. Adequate clearance around the vehicle and/or machinery for operator and plant access and containment of overspray should be considered. This is important if cleaning at height is required.

The washdown area should be large enough so that the largest vehicle is located on an impervious bunded area. This ensures that all wastewater is contained and operators are not required to reposition the vehicle.

As a guide, a working area of 2 m around the full perimeter of the extent of the largest vehicle should be sufficient to allow for clearance and manoeuvrability of mobile plant such as forklifts and containment of overspray.

A kerb nib wall at the perimeter of concrete slabs may be provided to minimise discharge from the slabs. The nib wall along the edges of concrete that are intended to be trafficable should be a raised rolled edge that drains inwards towards the washdown area. Elsewhere, the edge of the washdown area may have a 200 mm (H) × 200 mm(W) nib wall so that vehicles cannot easily mount the kerb.

Washdown area – slope

The design should allow gravity drainage of solids and wastewater to the sediment trap. Down slopes of about 3–4% and a cross slope of 2–3% are desirable. Slopes under 3% do not drain well when there is a buildup of mud/manure.

The slope chosen depends on site topography. For flat sites where earthworks are required to artificially create slope, lower slopes (<3%) are often chosen. For steeper slopes, the natural topography usually determines the slope.

Cleaning services

Primary cleaning requires water at both low volume/high pressure (LVHP) and high volume/low pressure (HVLP).

LVHP washers are adequate for general exterior and engine cleaning; HVLP water is preferred for removing large quantities of mud/manure and organic material buildup. Rigid or semi-rigid lances with nozzles with any combination of forward or 90° angle jets will facilitate cleaning in areas that are hard to access.

Compressed air is useful in removing dry material and cleaning seed and organic material out of radiators, air filters and inaccessible places. Air compressors can be single phase or three phase electric, petrol or diesel, stationary or portable. A retractable enclosed air hose reel suitable for outside exposure and air blow gun with a long nozzle for directional access are recommended.

Vacuum equipment is useful for cleaning cabins and dry material build up (seed and straw). Vacuum equipment removes this material rather than blowing it into less accessible areas on the machine or vehicle.

Hot water or steam may be required to disinfect vehicle/plant or equipment in areas which may have a local biosecurity requirement.

Effective sterilisation requires steam above 100°C as indicated by a jet of clear invisible steam between steam outlet and the visible condensate cloud.

Water supply

Water will normally be from the feedlot supply. Rainwater could be harvested from nearby buildings but recycled water may pose a biosecurity and health risk. A risk assessment should be conducted to determine the risks associated with using recycled effluent for vehicle cleardown.

Flow rates will depend on the demand of the facility and the water delivery equipment provided but pumping will usually be required, as flow rate and pressure supplied by gravity would be too low.

The supply should be supplemented with a suitably sized holding tank, which serves as a storage reservoir to equalise the fluctuations in demand. A suitable system or device should be installed that will shut off the water supply if the holding tank becomes filled to capacity, or due to a leak into the system or lack of maintenance pumping of the system.

Traffic movement/ accessibility

Entry and exit areas should be well gravelled to cope with anticipated vehicle movements – see *Section 17 – Pen and road surfaces* for further discussion on structural thickness and suitable materials for road construction.

The siting and layout of the facility should ensure good traffic management and flow.



This small concrete pad has limited downslope with no wastewater containment.



This concrete pad has suitable length and width and equipment storage, but it is flat with no wastewater containment.



This concrete pad is of suitable length, but too narrow. Water is supplied, but the pad is flat and there is no controlled wastewater drainage system.



Quadruple trafficable sedimentation basin side by side arrangement. Wastewater is diverted into one or more bays.



Dual trafficable sedimentation basins allow one to be taken offline to enable sediment to dry. Separate basins cost more than a side by side arrangement. These basins are adequately sized for cleaning machinery but do drain to bed level.



Drive in-reverse out design with platform for elevated access to vehicles. Wastewater drains to feedlot drainage system.

Infrastructure

Typically, the washdown facility will require minimal building structures.

The pumping equipment, air compressor and associated control equipment should be inside some form of shed or under cover.

The need for electricity and/or other energy sources at the facility needs to be determined and may help determine the facility location.

Electricity will be required at the site to operate water pumping equipment (cleaning/recycling) and lighting and could be a three phase supply. Electrical supply lines should be kept well away from the cleandown area where they may be contacted by vehicles or washing equipment.

Lighting may need to be installed to allow the washdown to operate beyond daylight hours if required.

For facilities that are constrained by area and/or sited adjacent to other operational or storage areas, a side screen may be considered to prevent the drift of over-spray.

Side screens can interfere with cleandown operations and manoeuvrability of plant and add to the cost of the facility.

An elevated platform may be needed for personnel to safely access the top of vehicles to be cleaned.

Low volume/high pressure water systems

Industrial high pressure water systems with a minimum pressure of 20.6 MPa (3000 psi) and a minimum pump volume of 20 L/min would be sufficient.

Reels for high pressure hose mounted at the outlets provide convenience and safety for operators and reduce the potential for damage to the hoses.

Wastewater treatment train

Wastewater should be contained, segregated and treated, or disposed of in accordance with the environmental authority for the development.

Wastewater may be drained to a sediment trap and oil/water separator then directed to a holding pond/s to be evaporated or treated to an acceptable standard prior to discharge.

Preliminary treatment

Wastewater is temporarily held in a sediment basin where heavy solids (e.g. nuts and washers), gravel, manure and silt are trapped. This reduces the sediment load in the wastewater.

Sediment basin designs are discussed in *Section 11 – Sedimentation removal systems*.

Solid waste management

Accumulated sediment must be removed and disposal of properly. If accumulated sediment reduces the storage volume of the sedimentation basin below the design volume, the efficiency of the basin will be decreased and sediment may be washed out into the holding pond.

Inspection experience will determine the required cleaning frequency for the accumulated sediment in the sedimentation basin.

The accumulated sediment may contain some hydrocarbons e.g. benzene, toluene, ethylbenzene, xylenes (BTEX)) and/or weed seeds. Sediment containing hydrocarbons and/or weed seeds should be excluded from the manure stockpile.

Safety

Handrails preventing access to the sedimentation basin should be fabricated to Australian Standards AS1428 (Standards Australia 2009b). A suitable ladder and handrails need to be fitted to any overhead platform.

Operation

Supply units can be fitted with detergent systems if degreasing or chemical cleaning is required.

Biosecurity

Washdown of vehicles and machinery also prevents the spread of weeds and fungal disease.

In areas of infestation, seeds and vegetative material collect on many parts of a vehicle or agricultural machine, but especially on the vehicle radiator and tyres.



A non-trafficable sedimentation basin grated to prevent access. The heavy grate must be removed to clean out sediment and debris. Not accessible to typical feedlot machinery.



Trafficable sedimentation basin with offset weeping wall/bar screen segment. Wastewater drains to bed level.

Quick tips

- The siting and layout of the facility should ensure good traffic management and flow.
- Size the washdown area on the largest vehicle to be cleaned down and allow a working area around the full perimeter for clearance and manoeuvrability of mobile plant such as forklifts and containment of overspray.
- A down slope of 3–4% will ensure good drainage.
- A trafficable sedimentation basin will facilitate removal of sediment. The width of the basin is set by the width of the cleaning equipment (e.g. bobcat, front end loader).
- Sedimentation basin access ramps should not be steeper than 1 in 10 – even for 4WD tractors.



This single trafficable sedimentation basin is adequately sized for cleaning machinery, and has handrails for safety. Wastewater drains to bed level.

Further reading

Tyers, G., Grech, C. and Baldyga, N. (2004) Machinery Hygiene, Landcare Note, LC0425 ISSN 1329-833X, Department of Primary Industries, State of Victoria.

Tasmanian Department of Primary Industries, 2004, Tasmanian Washdown Guidelines For Weed and Disease Control Edition 1, The Tasmanian Department of Primary Industries Water and Environment.

Department of Natural Resources, 2000, Machinery Inspection Procedures, Queensland Weed Seed Spread Project 2000, Queensland Department of Natural Resources, Brisbane, QLD.

Department of Natural Resources, 2000, Queensland Guideline for the construction of Vehicle and Machinery Washdown Facilities, Queensland Weed seed Spread Project 2000, Queensland Department of Natural Resources, Brisbane, QLD.

Environmental Protection Agency, 2005, Water Recycling guidelines, Queensland Government, Brisbane
<http://www.epa.qld.gov.au/waterrecyclingguidelines>



FEEDLOT DESIGN AND CONSTRUCTION

43. Automatic weather stations

AUTHOR: Rod Davis and Simon Lott



Well-sited 2 metre AWS with no nearby obstructions and a low security fence.

Introduction

Weather monitoring is an important aspect of feedlot management. Adverse weather conditions can affect cattle production and welfare, particularly during the hotter months. Feedlot operators should closely monitor local climatic conditions and review weather forecasts to monitor and manage the risk of heat stress in cattle. Weather monitoring may also be required to support feedlot environmental licences or development approval applications, particularly if there is the potential for odour or dust to affect neighbouring properties. Weather data can also be used for scheduling of crop planting (e.g. soil temperature) and/or effluent irrigation.

Design objectives

The design objectives for an automatic weather station (AWS) at a feedlot may include

- provision of climatic data to calculate Heat Load Index (HLI) and Accumulated Heat Load Units (AHLU)
- provision of climatic data to monitor or predict odour dispersion
- provision of climatic data for scheduling effluent irrigation
- provision of climatic data for scheduling manure and/or compost spreading
- storage of historical climate data
- compliance with environmental licences or development approvals
- siting to ensure representative data collection
- siting and installation to minimise potential damage and to facilitate maintenance.

Mandatory requirements

Feedlot environmental licences and development approvals may require the operator to collect meteorological measurements, with the parameters specified in the licence. This may be as simple as daily rainfall or as complex as wind stability on a 10 minute basis.

In NSW, the Environment Protection Authority guidelines for odour assessment require the collection of at least 12 months meteorological data for development approval applications where odour impact is expected. These data are used in odour dispersion modelling for the proposed site. A weather station may also have to be installed at the site to collect data for a minimum of two to three months so that the results can be correlated with a local Bureau of Meteorology (BOM) station if available.

In these cases, the design and siting of the weather station may have to comply with AS2922-1987 Ambient Air – Guide to the Siting of Sampling Units and AS2923-1987 Ambient Air – Guide for Measurement of Horizontal Wind for Air Quality for the data to be useable for legal and licensing situations.

NFAS standards require all feedlots to monitor HLI and AHLU of the cattle on feed. While an on-site weather station is not mandatory, it is strongly recommended because of the possible variation between the on-site micro climate and local weather forecasting.



Tipping bucket rain gauge (pluviometer) with the cover removed – records rainfall total and intensity (mm/hr).

Technical requirements

An AWS is a stand alone set of equipment constructed to measure and record specific attributes of the ambient environment. It relies on sensors to measure a physical property or condition over time.

Climatic parameters

Typical standard climatic parameters measured by an on-site AWS include

- rainfall
- ambient temperature
- relative humidity
- wind speed
- wind direction
- global incoming solar radiation
- global radiation on exposed surface (black globe).

These parameters allow calculation of Heat Load Index, Accumulated Heat Load Units and evapotranspiration.

Additional parameters may include

- barometric pressure
- soil temperature.

If the weather station is to be used to collect data for odour dispersion modelling or dispersion prediction, the following additional parameters must be recorded

- wind speed at 10 m and 2 m
- wind direction at 10 m

AWS configuration

Automatic weather stations fall into two basic categories.

- Preconfigured – these stations feature a standard suite of pre-wired sensors, easy installation and simplified programming. Typically they are not expandable, with no provision for additional sensors to be added. The standard suite of sensors includes rainfall, wind speed, wind direction, air temperature and relative humidity.
- Custom – these stations offer a wider selection of sensors and data transfer peripherals providing greater flexibility and expansion capabilities, but are more expensive.

Siting

The main determinants of how and where to site an AWS are the intended application and the surrounding environment of the desired location. The quality of the weather data from an AWS is a function of the quality of the sensors used and the appropriateness of its siting.

An AWS records the weather exactly at the point it is located. In a 'microclimate' application, readings may need to be inferred over a radius of 1–2 kilometres; in a 'meso-scale' application, readings may be intended to be inferred as valid for up to 25 kilometres. In terms of monitoring heat load events, the 'microclimate' or climatic conditions actually experienced by the cattle in the feedlot, including the effects of the immediate local terrain, are the most



A typical AWS setup with sensors for wind direction and speed, and black globe solar radiation mounted on the cross-arm. Logger is mounted inside blue box.



The black-globe sensor has a temperature probe inside to measure internal air temperature.



AWS mast with wind speed, wind direction and solar radiation at 10 metres, and other sensors at 2 m.



Well sited 2 metre AWS located in the centre of a feedlot with no nearby obstructions and a security fence to keep out livestock.



A less well sited AWS on a mound and shaded by close vegetation. Records would be unrepresentative of ambient conditions.

relevant. The ‘meso-scale’ will be important when the intended application is to measure the potential impacts to the surrounding environment such as odours, dust or other airborne particles.

The AWS should be sited so the variables measured are representative of the area of interest, and so it is located as close as possible to this area. However, subtle variations in exposure may still mean that the data may not be representative. Wind, air temperature, and water vapour pressure measurements may be affected by the ground surface type and roughness, soil moisture, regional topography and obstructions. For example

- Rainfall collection efficiency varies with height due to wind turbulence effects. Rain measured at 1 m above ground level is only 97% of rain measured at 300 mm.
- Temperatures measured over or close to a bitumen surface are significantly different to those measured over a grass surface.
- Wind speed measured at 3 m is significantly less than wind speed measured at 10 m. The wind direction may also be different.

In addition to difficulties with the correct exposure of instruments, changes in the long term exposure of the site should be considered. New structures such as buildings, shade, silos or water tanks, or vegetative screenings such as trees planted close to the instrument enclosure, will result in the area of representativeness being reduced and may also affect remote communication systems.

The AWS should be inspected regularly and any changes in the siting properly documented.

To ensure consistency between sites, an Australian set of standards for the physical siting and exposure of the meteorological instruments has been developed by the Australian Government’s Bureau of Meteorology (BOM) using the World Meteorological Organisation’s (WMO) guidelines (Bureau of Meteorology 1997).

Australian Standards have also been developed for siting and measurement of ambient air quality (AS2922-1987 Ambient Air – Guide to the Siting of Sampling Units; AS2923-1987 Ambient Air – Guide for Measurement of Horizontal Wind for Air Quality).

Ideally, the AWS should be placed in the centre of an open space of at least 12 m by 12 m which is covered by short grass and fenced robustly so that sensors are not damaged by livestock. If the weather station has sensors that are housed together, the area of the enclosure can be reduced. However, the fence must NOT affect sensor readings by shading, influencing wind movement or producing a rainfall shadow.

The site should be on level ground and not shielded by trees or buildings. It should not be close to steeply sloping land or in a depression where temperatures are frequently higher during the day and cooler at night. Rock outcrops, stone or gravel surfaces near the AWS should be avoided. Suggested heights and exposure of AWS sensors are provided in Table 1 and Figure 1.

To achieve optimum results, the BOM and Australian Standards should be consulted.

In an attempt to measure the actual conditions experienced by cattle, some feedlot managers have placed weather stations inside a pen or cattle alley. However, pen conditions can be extremely aggressive and can result in

- dust accumulating on and in sensors
- corrosive attack by organic matter
- sensor damage by cattle
- wiring damage by rodents
- sensors and wiring damage by birds
- sensors and circuitry damaged by electromagnetic fields from welding during pen repairs
- equipment damage by cleaning machinery and routine feedlot maintenance.

Table 1. Suggested heights and exposure of AWS sensors (Standards Australia (1987b))

Sensor type	Measurement height above ground level	Exposure considerations
Wind	2 m / 10 m	No closer than 10 times the obstruction's height – See Figure 1.
Air temperature and relative humidity	1.25–2 m	The sensors must be housed in a ventilated radiation shield to protect the sensor from thermal radiation. No closer than four times the obstruction's height and at least 30 m from large paved areas.
Solar radiation	To facilitate levelling/ cleaning install at a height of 3 m or less	The sky should not be blocked by any surrounding object. Objects less than 100 above the horizontal plane of the sensor are allowed.
Rain	300 mm (at greater height wind affects the accuracy of measurement)	The sensor no closer than four times the obstruction's height. The orifice of the gauge must be in a horizontal plane, open to the sky, above the level of in-splashing.

Figure 1. Schematic siting requirements for an AWS

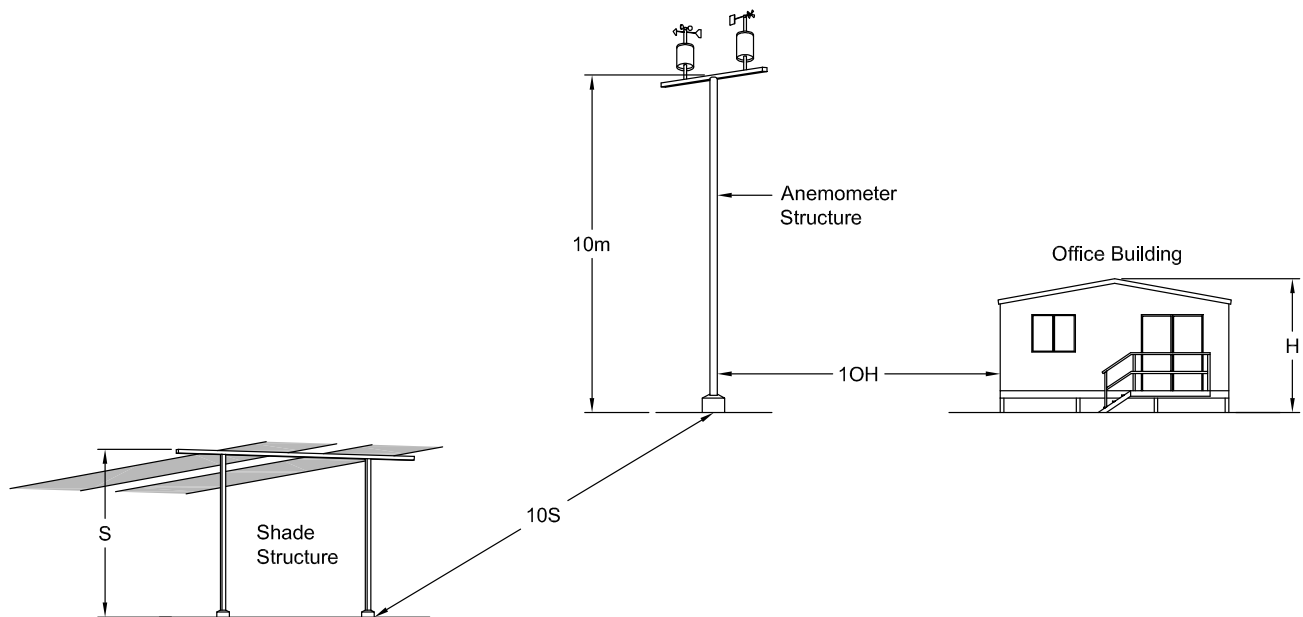



Typical 2 m solar-powered AWS with remote access.

Note omni-directional antenna fixed to AWS mast and separate uni-directional high gain antenna on stand alone post. Data can be downloaded and all sensors checked by remotely dialling into the AWS.

Sensor configuration

Sensors should be selected to be appropriate to the user's requirements. The quality of the final data recorded can only be as good as the quality of the sensors used, and no subsequent analysis of the data can improve its accuracy or reliability.

The integral component of the sensor is a 'transducer' which detects one form of energy and converts it to another. For example, a temperature sensor detects temperature of a probe and converts it into an electrical signal. Electronic circuitry in the sensor itself or in a centralised processor gathers these signals. As the mechanical and/or electrical components of sensors degrade over time, the characteristics of the transducer and signal may alter over time; hence, the need for high quality sensors and regular sensor calibration for accurate measurement over time.

Fundamental characteristics which make up the accuracy and precision of a sensor are

- *Resolution* – the smallest change the device can detect. Note that this is not the same as the accuracy of the device.
- *Repeatability* – the ability of the sensor to measure a parameter more than once and produce the same result in identical circumstances.
- *Response time* – normally defined as the time the sensor takes to measure 63% of the change.
- *Drift* – the stability of the sensor's calibration with time.
- *Hysteresis* – the ability of the sensor to produce the same measurement whether the parameter being measured is increasing or decreasing.
- *Linearity* – the deviation of the sensor from ideal straight line behaviour.

All of these factors go into defining the accuracy and precision of a sensor but some are more important in particular situations than others. For example, for monitoring climatic temperature changes, a significant amount of data is collected over a long period so the sensor should have very little drift. To measure short term wind gusts, the repeatability of the device and the response time become more important.

For a feedlot application, the most important factor is the robustness of the sensors. In general, feedlots are harsh environments so the sensors need to be well designed and constructed, have strong waterproof housings for the electronics and be able to withstand extremes of climate variability.

Sampling period and recording frequency

Digital recording should provide for a sampling of sensor readings at intervals of no longer than 60 seconds.

The period over which a parameter is averaged depends upon the application. Wind speed and wind direction are averaged over a 10 minute or 15 minute period. One hour averages are used for most other parameters.

Most parameters measured are averaged with a simple arithmetic method. However, wind direction must be computed with a method that accounts for the angular nature of the values.

In those feedlots that are required to record climatic parameters as part of licence conditions, the recording frequency will be stated in those conditions.

Algorithms

Using information from the sensors it is possible to calculate a host of important variables for feedlots, including heat load on cattle and potential evaporation. For example, irrigation requirements can be determined using potential evapotranspiration readings to determine the rate of water loss from irrigation areas receiving effluent water.

The algorithms used to derive meteorological variables should be meaningful, documented and comparable between different weather stations.

For example, the maximum temperature derived from 1 second readings can be quite different to a maximum temperature derived from hourly readings, wind gusts based on 1 second readings will be significantly greater than gusts based on 3 second readings, and scalar averaging of wind direction generally produces meaningless results.

Lot feeders or their consultant should confirm with the manufacturer the algorithms used and the meaning of the meteorological variables derived. The algorithms used and all changes to those algorithms should be documented.

Heat Load Index (HLI)

Heat Load Index (HLI) has been developed as an indicator of the environmental heat load placed on cattle. The HLI has been tested and proves to be a good indicator of physiological stress.

Refer to the Katestone Environmental website for the current method of calculating HLI. (www.katestoneenvironmental.com.au)

Accumulative Heat Load Units (AHLU)

The accumulative time of exposure to thermal load is crucial to determining the thermal status and wellbeing of feedlot cattle. AHLU has been developed to give some indication of the amount of heat that is accumulated by an animal when it is exposed to environmental conditions that are above its ability to maintain thermoneutral conditions (threshold value). The threshold value is selected on the basis of the animals' suspected vulnerability to high heat load. Every hour that an animal is above its threshold HLI value, it will gain heat. This additional heat load accumulates over time and is reflected as an increase in body temperature.

In order to calculate the AHLU, several parameters are required

- Heat Load Index (HLI)
- Upper limit of the Thermoneutral Zone (UL)
- Lower limit of the Thermoneutral Zone (LL) (Fixed at 77)
- Interval (in hours) between successive HLI estimates (T)

The Upper Limit is variable and depends on factors such as

- cattle characteristics
- pen management practices
- mitigation measures.

Refer to the Katestone Environmental website for the current method of calculating AHLU. (www.katestoneenvironmental.com.au)

Further information on estimation and forecasting of HLI and AHLU can be found at Katestone Environmental (www.katestone.com.au). The meteorological parameters that influence the HLI and the AHLU forecasts can vary significantly over relatively short distances and therefore an on-site AWS, sited reasonably close to the feedlot pens, will provide the best results.

Most AWS marketed for feedlots incorporate standard algorithms for the calculation of HLI and AHLU.

Communication

AWS can be configured for direct download via a continuous communications link or remotely. The communications system used must be reliable, inexpensive and follow standard protocols for data transfer from the AWS to the user.

To select the best communication option, the following points should be considered

- how often you need to download your weather data
- power availability at the site
- capital expenditure versus running costs

A summary of each available communication option follows

- **Direct cable connection**
This is a low-cost solution suitable for distances up to 100 metres, but it does need lightning protection. Normally, the cable connects to the serial port of a computer but it can be connected to your local area network (LAN) via a Serial to Ethernet converter if available. This type of connection is ideally suited as a continuous access between the office PC and AWS, providing 'live' weather monitoring.
- **Telephone landline**
A standard telephone line can be used via either a mains powered or solar powered modem. Any PC connected to the Internet is able to contact the weather station using this connection, allowing access to the AWS from almost any PC in the world. This method is normally cost effective only if an existing phone line is available at the AWS site. Line rental and call costs have to be considered; this method is not suitable as a continuous link due to continuous time-of-use and associated call costs.
- **Mobile data connection**
This style of connection allows a wireless link to the AWS from any PC connected to the Internet. It is simple to set up and will provide data from equipment sited in remote areas.

Coverage must be available at the AWS site for the network and provider you choose. Both GSM (2G) and 3G networks can be used. The Australian 3G network has a wider regional coverage area.

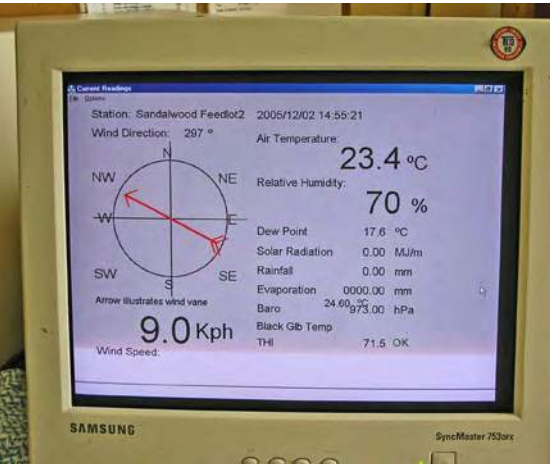

A direct link from the AWS to the feedlot office allows real time display of climatic conditions. This is particularly important during periods of high heat load.



AWS with radio link to office.

- **Radio links**

Radio links can be used where telephone services are not available, and for distances up to 10–20 kilometres. Line of sight is required but these systems can include repeaters to solve line of sight problems. Generally, radio links have higher capital costs, but no usage costs means that the overall cost is less for long term installations.

The choice of system is dependent on the distances required and the availability of power on site or costs of solar power. This type of connection is ideally suited as a continuous access between the PC and AWS, thus providing 'live' weather monitoring.

- **Satellite connection**

For completely remote access, a satellite phone can be fitted to the AWS.

Most feedlots use UHF, mobile or direct communication systems because they offer continuous or remote access at large distances from the office and they are similar to other telemetry used in agriculture, such as pump control systems or mobile phone links. AWS can be configured to issue warning messages of impending heat load events to the mobile phones of nominated people such as employees, vets and nutritionists.

Installation

Australian Standard AS2923-1997 provides instructions for siting, setup and commissioning of sensors for measurement of ambient air quality. Typically, manufacturers provide practical information on the setup and installation of their AWS and these should be consulted together with AS2923. The key issues to consider when setting up the AWS after the site has been selected are

Support posts – before concreting, ensure that support posts are

- orientated so that sensors or auxiliary equipment are aligned correctly (e.g. solar panels)
- set to the correct height
- vertically aligned.

Protection of cables – all exposed cabling needs to be protected from physical damage. Damage from maintenance activities such as whippersnippers and from bird chew are common.

Protection of the AWS – to prevent physical damage to the system, some form of fencing will need to be provided. The nature of the risk (e.g. livestock, machinery, people) will determine the type and size of the fencing. The effect of the fencing on measurement (e.g. sensor shading) needs to be considered.

Maintenance

Regular and proper maintenance of the AWS is essential for continuing accurate data. Integral to the sensor and its calibration is sensor maintenance. All sensors need to be cleaned and checked periodically to verify their calibration. A maintenance program should reassess the calibration of all sensors. The weather station should be easy to maintain, and maintenance should be possible without affecting the climate record and recording frequency. For example, sensors should be able to be unplugged whilst they are being serviced without affecting the recording of other variables.



A rain gauge installed on a 600mm post to prevent flooding.



A rain gauge installed in a site subject to stormwater flows. The gauge was inundated and all components had to be replaced.



Spider webs and dust may affect the ventilation of humidity and temperature sensors within the screen.



Dust – rain gauges need to be frequently inspected for dust accumulating in the bowl and cementing after heavy dew. Do not site AWS close to gravel roads.



Maintenance of site – grass and weed seeds blocking the funnel of the rain gauge will affect data quality.

AWS should be chosen for their ease of maintenance.

Many of the cheaper AWS lack robustness and require more frequent maintenance to replace electronics and/or sensors; they often cannot be serviced in the field and need to be returned to the manufacturer for periodic calibration or replacement. However, even the highest quality AWS do degrade over time and still need to be serviced and maintained regularly. In time, even the highest quality sensors will need to be recalibrated and/or replaced. Most good quality sensors simply need to be recalibrated rather than be replaced.

It is important to consider the lifetime costs of an AWS rather than just its initial purchase cost. Lifetime costs will include initial purchase (hardware and software), installation, annual maintenance, sensor replacement frequency and sensor, software update and data loss costs. Generally, the lower the initial cost, the higher the ongoing costs and the number of periods when little or no useful data is recorded.

More maintenance will be required if the weather station is in an aggressive environment (e.g. dusty or moist), and this will dictate the maintenance frequency. For example, AWS located in the feedlot will require more frequent maintenance due to higher dust loads than an AWS sited outside the feed pen area.

Maintenance should also be timed to ensure that the AWS is at its peak operating performance at critical times throughout the year such as prior to summer heat loads. If the weather station is located close to dust-generating areas, the primary maintenance problem will be dust accumulation on and in sensors. Poor maintenance can translate into poor management decisions affecting cattle production and welfare, data loss and increased repair costs with time.

As a guide, an AWS should be checked and serviced at a maximum of 12 months, with 3 to 6 months recommended in aggressive environments. For high quality data, sensor calibration should be checked every two years.

Basic routine and simple maintenance that can be carried out on an AWS by feedlot employees includes

- Regular checking and clearing the rain gauge collector of dust and debris. Bird droppings and accumulated dust during dry periods and with no flushing are a particular problem.
- Check the bearing in the wind speed anemometer sensor housing by listening for any noises as the cups rotate. The cup rotation can also be halted by hand to check for any friction evident at low wind speed. The only way to check the calibration in the field is with a newly calibrated anemometer.
- Check the bearing in the wind direction sensor housing by listening for any noises as the vane rotates.
- Remove any cobwebs from the wind speed anemometer cups and wind direction vanes.
- Check the solar radiation sensor for dust and debris and wipe clean the top of the sensor as required.
- Wipe off excess dust from the relative humidity and air temperature radiation housing.

- Keep grass short around the rain gauge to ensure that grass seeds or vegetative material do not block the gauge.
- Check for loose nuts, bolts, studs or cable connections and tighten or repair as required.
- Protect the sensor cables with flexible conduit to provide protection from damage. Typical issues include bird or animals such as foxes, mice and cattle that chew or inadvertently cause physical damage.

Sensors should be checked, serviced and calibrated on a regular basis – most likely by the manufacturer or experienced consultant. Simple calibration checks can be made using thermometers (ambient air temperature), sling psychrometers (relative humidity), hand held anemometers (wind speed), a sight compass (wind direction) and other calibrated sensors to benchmark readings. Pocket weather devices or weather meters are relatively inexpensive and are ideal for in-situ checking of AWS sensors by employees. For example, the Kestrel-type devices can measure and record wind speed, temperature, RH and barometric pressure.

Sensors should only be returned to the manufacturer when the deviation from the calibration reading is unacceptable.

The AWS manufacturer can provide advice regarding the inspection and maintenance of their units.

Data management

The capture, storage, back-up and output of recorded data should be considered when selecting an AWS. The data management system used should be

- practical – the system should be flexible enough to allow additional sensors to be added without having to re-process the AWS records into a new format.
- user friendly – the system should be simple and the user should be able to directly read the output from the sensors and recorded data without proprietary or specialist programs to decode or manipulate the data.
- flexible – the data should be easily transferred between software applications e.g. from an ASCII text file straight into a Microsoft Excel spreadsheet. This also allows easy exchange of data between regulatory agencies, consultants and other users for review and processing with minimum reformatting.
- independent of the manufacturer – the data management should not be dependent upon a manufacturer's proprietary software. Proprietary software may reduce the ability to exchange data and the flexibility to manipulate data if required. This also impedes competition between manufacturers.

The use of standard software and standard formatting allows easy management of data and increases useability and functionality. The BOM has standard data formats and the data collected by the AWS should be configured to comply with one of these formats. The standard outputs include *one second format* (for maintenance and real time read-outs), *one minute format* (data logging, display), *ten or fifteen minute format* (data logging), *hourly format* (data logging) and daily maximum and minimum or totals format.



All cables to and from the AWS need to be protected from damage by machinery and animals. Cockatoos and rodents chewing on exposed cables lead to loss of data and expensive repairs.



Well protected cabling on an AWS.

Archiving and retrieval

AWSs generate large volumes of data. The archival and retrieval of AWS data must be considered.

Development conditions may require data to be kept for a defined period but it is best to ensure that all AWS data be kept permanently.

This will require balancing the need to store high temporal resolution data against the large volumes generated.

When deciding on a data storage system, consideration should be given to the ease of quality control and retrieval of the data. This applies as equally to data stored on hard copy as to data held in electronic form.

The Bureau of Meteorology's National Climate Centre maintains the Bureau's data archives and, under certain conditions, stores data from other agencies. Before any data can be accepted into the Bureau's climatological database, the foregoing issues must be addressed.

The Bureau's Data Management Section (and the Climate and Consultancy Services Sections in each state) can provide advice regarding the requirements for data to be archived in the Bureau's climatological database. Generally, the AWS installation and operation should follow the procedures outlined in this document.

Quick tips

- Feedlots should install a AWS to at least monitor HLI and AHLU because there can be considerable variation between the on-site micro climate and local weather forecasts. A preconfigured AWS offers a standard suite of pre-wired sensors but no additional sensors can be added later.
- A custom AWS offers a wider selection of sensors and data transfer peripherals providing greater flexibility but at a higher cost.
- The AWS should be sited so the variables measured are representative of the area of interest and located as close as possible to the area of interest.
- Carefully consider the proposed site for an AWS and potential changes in the long term exposure of the site. New structures, such as buildings, shade, silos or water tanks or planting trees or shrubs near an AWS may affect the representativeness of the data recorded and/or the remote communication system.
- Refer to the Katestone Environmental website for the current method of calculating HLI and AHLU.
- Radio communication links between the AWS and the feedlot office have higher capital costs but small usage costs.
- Regular and proper maintenance of the AWS is essential to obtain accurate data.
- Basic routine and simple maintenance such as cleaning rain gauges, cobwebs and dust from solar panels on an AWS can be carried out by feedlot staff.

Further reading

- Lott, S.C. (2004). Appendix B 'Weather monitoring in feedlots' in Final Report FLOT.322 'Cooling water for lot-fed cattle.' North Sydney, Meat & Livestock Australia Ltd.
- Standards Australia (1987a). Ambient Air - Guide for the siting of sampling units. (AS 2922-1987). Sydney, NSW, Standards Australia.
- Standards Australia (1987b). Ambient Air - Guide for measurement of horizontal wind for air quality application. (AS 2923-1987). Sydney, NSW, Standards Australia.
- Sparke, E.J., Young, B. A., Gaughan, J.B., Holt, M. and Goodwin, P.J., 2001, Heat load in feedlot cattle. Final Report FLOT.307, 308, 309. North Sydney, Meat & Livestock Australia Ltd.
- Young, B.A. and Hall, A. B. 1993, Heat load in cattle in the Australian environment. Australian Beef. R. Coombes. Melbourne, VIC, Morescope Publishing.
- Mader, T.L., Davis, M.S. and Brown-Brandl, T., 2006, Environmental factors influencing heat stress in feedlot cattle. *Journal of Animal Science* 84(3): 712-719.
- Gaughan, J.B., Goopy, J. and Spark, J., 2002, Excessive Heat Load Index for feedlot cattle. Final Report FLOT.316. North Sydney, Meat & Livestock Australia Ltd.
- Bureau of Meteorology 1997 Observation Specification No. 2013.1 – Guidelines for the Siting and Exposure of Meteorological Instruments and Observing Facilities. Bureau of Meteorology – Department of the Environment, Sports and Territories.
- Bureau of Meteorology (2005) *Automatic weather stations for agricultural and other applications*.
- Katestone Environmental, 2013, Cattle Heat Load Forecasting, www.katestone.com.au
- Killip C., Smith L. and Haigh T., 2013, Weather Station Review. Report B.FLT.0386 Part A. North Sydney, Meat & Livestock Australia Ltd.



FEEDLOT DESIGN AND CONSTRUCTION

44. Covered housing systems

AUTHORS: Rod Davis, Peter Watts and Ross Stafford

Introduction

Animal welfare, environmental and practical management of a feedlot all become greater issues in areas with more extreme conditions such as high rainfall or low temperatures. For example in hot, high rainfall areas, the feed gets wet and animals are heat stressed; in cold, wet and windy areas, the issues are cold stress with manure management and cleanliness of cattle (e.g. dags).

In more extreme environments, covered housing is usually adopted to control climate and minimise the effect of adverse weather conditions, and improve cleanliness and the welfare of cattle. Environmental management issues such as minimising odour and/or effluent runoff are additional secondary advantages.

The covered housing system adopted will depend upon the level of protection required and the issues being addressed, such as more ventilation against hot conditions or less ventilation against cold winds.

The main disadvantage of covered housing is the initial capital cost of constructing sheds and the ongoing costs associated with maintaining pen bedding and managing manure. The higher stocking density possible results in an increased accumulation of manure, and this also stays wet due to the shaded environment. Some form of absorbent bedding is required to hold moisture and provide an acceptable surface over the concrete floor for cattle to lie on. A slatted floor will allow urine and manure to pass through to a drainage system below. Slats should have a non-slip surface for cattle.

Design objectives

Covered housing systems should be design and constructed to

- provide a housing environment for cattle where animal welfare and protection from the environment are maximised
- provide a housing environment that maximises production performance of cattle and is functional from perspectives of feed management, livestock handling and manure management
- promote safe access for cattle to and from the feeding pens
- be structurally sound
- promote good natural ventilation
- optimise the management and removal of manure and spent bedding from the pens
- minimise ongoing maintenance costs
- provide a safe working environment for people.

Mandatory requirements

Compliance with

- Australian Animal Standards and Guidelines for Cattle (DAFF, 2013)
- National Guidelines for Beef Cattle Feedlots in Australia (MLA, 2012a)

- National Beef Cattle Feedlot Environmental Code of Practice (MLA, 2012b)
- NFAS standards (AUS-MEAT, 2011).

The building elements such as concrete footings, floor slabs and steel structures should comply with the structural provisions of the Building Code of Australia (BCA) and local building regulations and be designed in accordance with the relevant Australian standards.

Design choices

New construction or redevelopment of a covered housing facility must incorporate factors such as

- site selection and location
- shed configuration and orientation
- shed design e.g. cross section, layout
- ventilation
- insulation
- water reticulation and placement
- feed distribution
- lighting
- waste collection and management
- pen layout and design
- durability and maintenance.

Site selection and location

Selecting an appropriate site for covered housing within the overall layout of the feedlot will optimise the efficiency of operations, as covered housing facilities are permanently located.

Most site selection criteria for uncovered feedlots can be applied to covered housing systems e.g. manure storage, livestock handling, feed processing and distribution, access, topography, water storage and supply, drainage and geotechnical aspects. However, some criteria such as pen area, stocking density and topography are quite different. Site considerations are discussed in *Section 2 – Feedlot site layout*.

Shed configuration

The housing configuration depends on the issue being addressed e.g. exclusion of rainfall or cold winds.

The roof may partially (Figures 1 and 2) or fully cover the feeding pens (Figures 3 and 4). In a partially covered design, the roof would cover the feed bunk only or the bunk plus about one third of the pen area. The sides of the structure may be closed, partially closed or open. As a minimum, the feed bunk area should be covered. Fully covered pens cost more but reduce effluent control requirements as there is no pen runoff. Partially covered pens cost less, but require effluent control systems.



Fully covered double row housing system

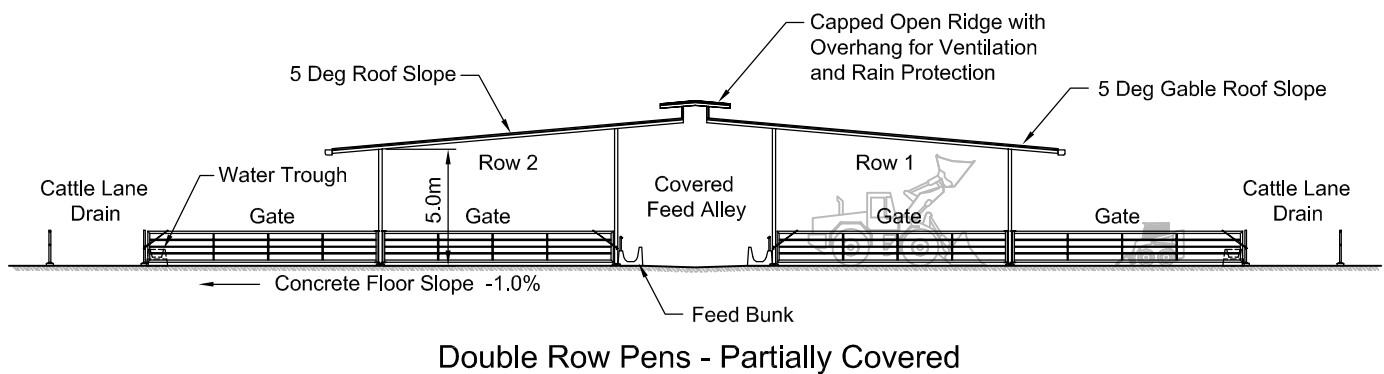

Figure 1. Typical end elevation – partially covered double row shed

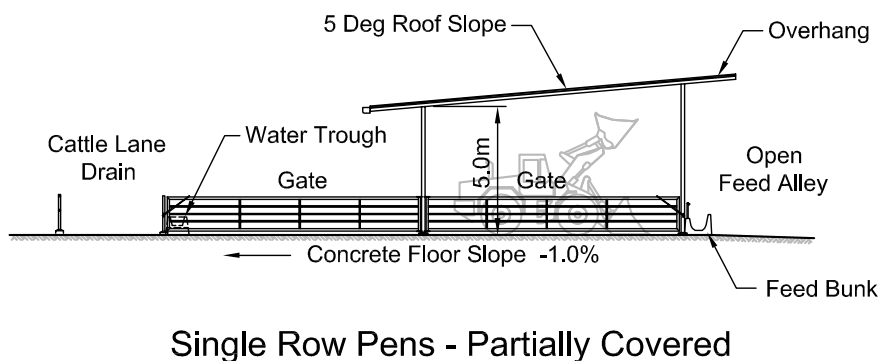

Figure 2. Typical end elevation – partially covered single row shed



Gable roof with centre ridge vent – no end or side walls and a high ceiling height promote good ventilation. The small concrete end walls enable pen cleaning equipment to pick up spent bedding.

Orientation

The orientation of the shed depends on the environmental issue being addressed. An east-west orientation of open-sided sheds will result in less direct sunlight penetrating underneath the roof or awning during daylight hours. A north-south orientation will allow sunlight into the pens during the morning and afternoon to promote the drying of bedding material.

If protection from cold, wet and windy conditions is required, the open side of the shed should be away from prevailing wind direction and preferably north facing.

Shed spacing

Multiple sheds should be spaced apart a distance of three to five times the eave height for adequate natural ventilation and for fire safety considerations (Figure 5).

Shed design

The main purpose of a shed design is to protect cattle from cold wind, rain and/or extremely high or low temperature. Uninsulated, open, naturally ventilated housing is recommended over fully enclosed environmentally controlled systems.

Environmentally controlled systems need to be heavily insulated and supplemented with additional cooling or heating methods if required. The shed will also require a controlled mechanical

ventilation system that maintains a satisfactory air quality within the structure. Apart from the cost element, environmentally controlled systems are less practical from a feed delivery, animal movement and manure management perspective for beef cattle.

The shed design may be a single row of pens under cover (Figure 3) or a duplicate row of pens on either side of a central feed alley (Figure 4). Sheds should be designed with high eaves, open sides and open ridge caps to promote ventilation. If cold winds are to be excluded, wall sheeting will be required to partially or fully close in the appropriate sides. Mechanical ventilation may be required to ensure adequate air circulation and ventilation. Ridge caps must allow sufficient overhang to prevent wind-driven rain passing through the gap. Sheds must allow easy access for machinery to deliver feed and clean pens.

The depth of the shed increases the level of wind protection for cattle.



Partially covered single row housing system

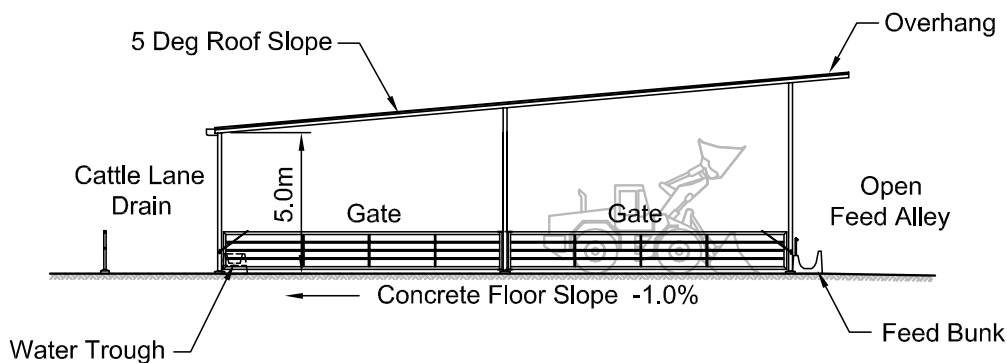

Figure 3. Typical end elevation – fully covered single row shed

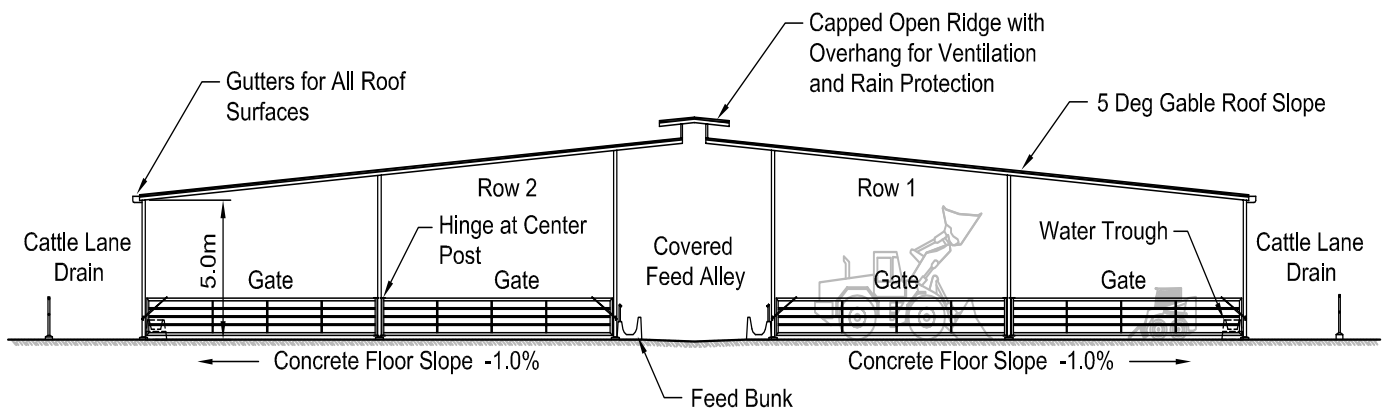

Figure 4. Typical end elevation – fully covered double row shed

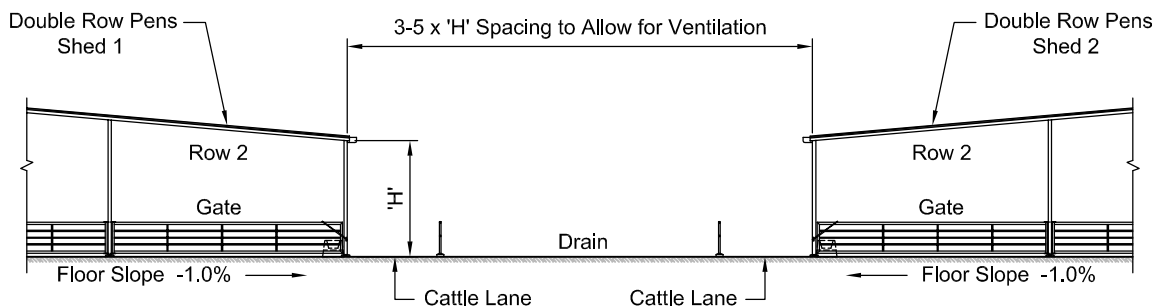

Figure 5. Typical end elevation – fully covered single row shed



Single row gabled roof system with uncovered feed bunk



Gable, trussed roof with sheeted end wall

Eave height

The type and working height of machinery that will be used, combined with a suitable clearance (600 mm minimum) to overhead structural elements such as beams and roof sheets, will determine the minimum eave height. Typically, the minimum eave height will be about 3.5 m.

Ventilation

Proper ventilation of covered housing systems is of paramount importance for people working in the facility as well as for animal health and performance. Proper ventilation consists of exchanging air inside the structure with fresh air from outside uniformly throughout the structure. The required rate of air exchange depends on a number of variables including the conditions of the outside air (temperature and moisture level), cattle population and stocking density.

High moisture, manure emissions (particularly ammonia), pathogens and dust concentrations in poorly ventilated or unventilated housing provide an adverse environment for cattle and employees. For example, ongoing levels of high humidity can be a contributing factor to lung infection and respiratory disease in cattle.

Air intake and exhaust openings should be provided (Figure 4) when localised winds do not provide adequate ventilation. Sidewall openings can provide air intake. Air exhaust vents should be located in the peak or apex of a gabled shed and should extend the length of the roof line (Figure 4). The amount of rain that can enter the shed through this vent should be minimised by adequate capping along the length of the roof line.

Mechanical ventilation such as fans or blowers should not be required if the shed is designed and located properly. If mechanical ventilation is required, fans should exhaust air from the structure and be mounted such that pen cleaning machinery is not obstructed.

Lighting

Artificial lighting should not be required in open, naturally ventilated housing. In fully enclosed sheds, skylights should be considered or the installation of artificial lighting.

Support columns

Where possible, clear span structures are preferred. Columns should not be placed inside pens other than in line with fences. No columns should be placed on the alley side of feed aprons or troughs. Columns should be encased in concrete to a height of approximately one metre (1m) to prevent corrosion around their bases and damage from pen cleaning equipment.

The support column spacing will be determined by the pen shape and size.

Roofing

For single row shed design, a mono-slope roof is adequate. Mono-slopes are most identifiable by their sloped roof or truss. The pitch of the roof has an effect on ventilation, water carrying capacity of the roof area and lifespan. Typically with a steeper roof, more debris is washed off the surface during rain events, improving its effective lifespan.

Typical roof pitches are in the order of 2° to 18° but a minimum roof slope of 5° (1V:12H) is recommended. As the pitch of a roof line increases, the overhang on the high side also needs to increase so that rain does not enter the shed; similarly, less overhang is required on the low side. Figure 3 illustrates a mono-slope roof shed.

For sheds with double row layouts and a central feed alley, a gable building with a central roof vent will be required (Figure 4). Roof pitches should be steep and high enough to promote good natural ventilation and rainfall runoff with a minimum roof slope of 5° (1V:12Hd).

All roof runoff should be collected in gutters and diverted away from the controlled drainage area of the feedlot. As the runoff is not contaminated it may be directed to storage ponds for later use.

Roofing is most commonly metal sheeting of various profiles. A wider profile (e.g. trim deck) has a larger water carrying capacity than a closer or corrugated profile.

Bedding storage

A supply of bedding will need to be stored under cover in or near the building/s to reduce hauling costs. Storage space depends on the number of cattle, stocking density, bedding density and frequency of replenishment. Bulk density will be primarily influenced by moisture content.

Table 1. Bulk densities of bedding materials

Bedding material	Bulk density kg/m ³
Sawdust	250–400
Whole, unground rice hulls	110
Sand	1200
Cereal straw	100–180
Wood chips	350–500

Pen layout and design

A good pen layout promotes quiet and safe cattle movement, good access to feed and water, efficient removal of manure and spent bedding and free drainage. The following factors should be considered when designing the pens for covered housing systems.

Stocking density

The stocking density describes how much area is allowed for each animal in the pen. Refer to *Section 9 - Overall pen layout* for further information on stocking density with the stocking density selected on the size of animals to be fed and the type of housing intended. Densities in the range between 2.5 m² and 6.0 m² per head are recommended for fully covered pens, while 5.0 m² to 9.0 m² per head is adequate for partially covered pens. The higher stocking density and associated heavier moisture (in manure) accumulation rate requires some form of absorbent bedding.



Roof water collection system



Double row housing feed bunk

Bunk space per head

The feed pen must ensure cattle free access to feed. The feed apron or trough should run along the full length of the front of the pen, while the water trough should be located at the rear of the pen. A minimum of 180 mm of feed trough space should be allocated for each animal in the pen. See Section 19 – Feeding systems for further detail on feed bunks.

Pen slope

A gradual slope from the feed apron or trough to the rear of the pen is necessary to drain any moisture that is not absorbed by the bedding. Slopes should be between 0.5% and 1.5% for covered pen surfaces and between 1% and 2% for uncovered pen surfaces. A sufficient grade on the pen will also help shed water during the construction phase.

Pen capacity

The pen capacity should be aligned with the expected consignment numbers or multiples thereof of cattle entering or leaving the feedlot. Often this will match the number of cattle that can be transported on a single deck of a standard livestock transport vehicle (see Section 22 – Reveal and dispatch).

Dimensions

The dimensions of a feed pen depend on the holding capacity of the pen, stocking density and the amount of feed trough space required. Figure 6 shows how stocking density (SD), trough length (TL) and pen capacity relate to the dimensions of a typical feeding pen. Where shed structures require columns within the pen area, pen dimensions may also be determined by the spacing of the shed frames to ensure that fences are in line with columns.

A pen depth twice the width allows gates to be installed in the fenceline which can be swung across the face of the pen to temporarily pen the cattle either against the rear of the pen or feed bunk, to allow pen cleaning to occur without removing the cattle from the pen. In this arrangement, the entire row of pens can be cleaned along one side simultaneously. The cattle can then be moved to the opposite side of each pen by swinging the second gate across the face of the other half of the pen, enabling the row of pens to be cleaned.



Single row housing with delivery of feed by gantry system running on fixed rails and connected to conveyor belt.

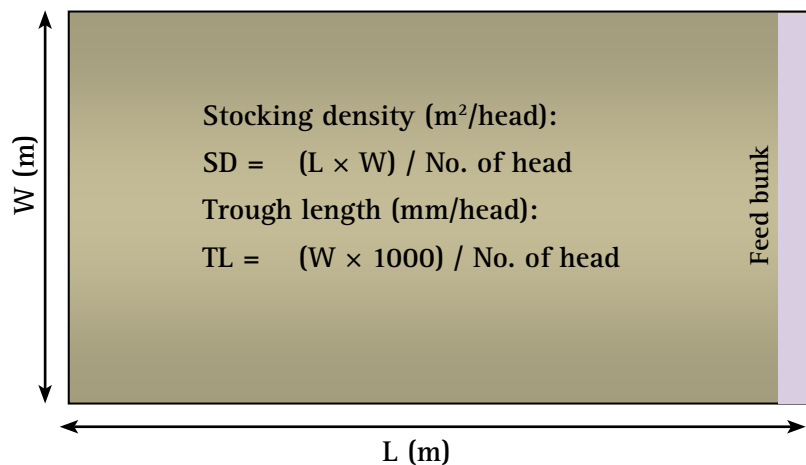

Figure 6. Dimensions of a single pen

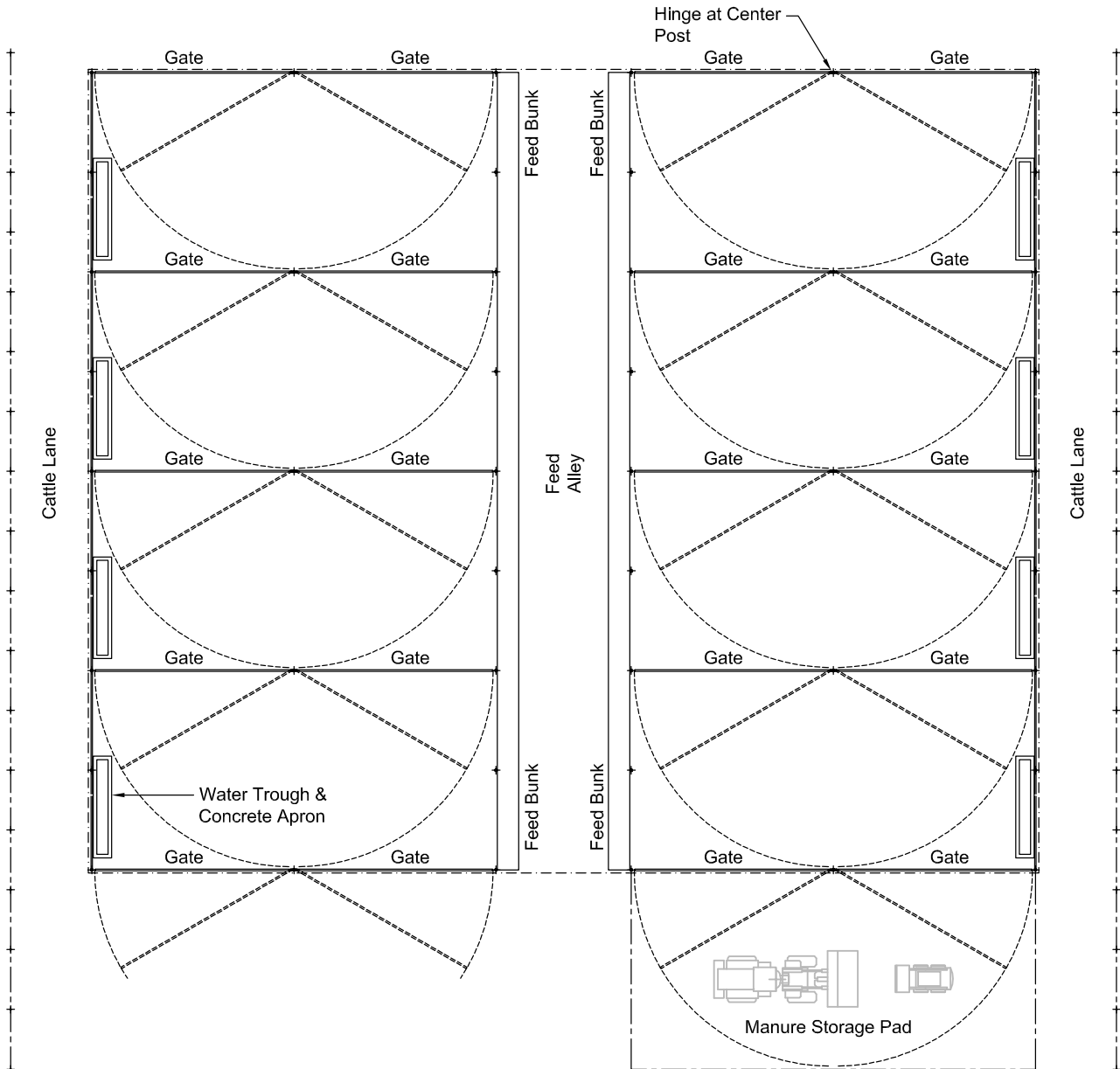

Figure 7. Plan view of a double row of pens with a central feeding alley

Gates and fencing

Gates and fencing provide a way of safely moving cattle around the feedlot in a controlled way, in all weather conditions and with minimal disruption to other feedlot operations. The design criteria for gates and fencing in a covered housing feedlot are similar to an uncovered feedlot. These considerations for gates and fencing are discussed in *Section 15 – Fences, gates and lanes*. The following additional factors should be considered when designing gates and fencing for covered housing systems.

Location

Cattle must be able to easily move into and out of the pens when being handled. Cattle lanes for access to the feeding pens should run along the bottom end (opposite the feed apron or bunk) of



Cattle access lane outside housing shed



Half-covered cattle lane running length of shed – roof is guttered to prevent runoff directly into cattle lane.

the pens. Laneways may be positioned inside (covered) or outside the shed. Cattle can be moved into feeding pens through gates on the back fence of pens, which open into and across the laneway. Where possible, cattle lanes should not cross any service roads as disruption to feeding and cleaning operations can occur when moving cattle. If the spacing of the sheds is adequate, cattle lanes can be shared by a row of pens on either side.

Width

Cattle lanes should be between 4 m and 5 m wide to allow free movement of cattle and machinery (if required). See *Section 15 – Fences, gates and lanes* for further information on cattle lanes.

Surface

If the cattle lanes are under the roof of the shed, they are best concreted so that cattle can be moved around the shed in any weather conditions. The surface should be stamped with a grooved pattern to prevent cattle slipping. See *Section 24 – Buildings* for further information on non-slip concrete surfaces. If the cattle lanes are not under the cover of the roof, they can be constructed of sound base material.

Slope

Cattle lanes should have a longitudinal slope of approximately 0.5 to 1% to assist drainage.

Materials

Materials are identical to those used in open-air pens. See *Section 15 – Fences, gates and lanes*.

Water troughs

Cattle must have free access to water. For fully covered pens, the water trough should be located at the rear of the pen with its length parallel with the back fenceline, rather than in the dividing fenceline between pens where it would prohibit pen to pen cleaning (Figure 7). Use Position F as shown in *Section 20*.

For partially covered pens, the water trough should not be located at the rear of the pen with its length parallel with the back fenceline as this will restrict drainage out of the pen. Use Positions A or D, not Position F, as shown in *Section 20*.

Water trough design is similar to open air pens. See *Section 20 – Water trough design and sewer systems* for further detail on water troughs.

Flooring

The flooring should provide a comfortable and safe surface for cattle to move and rest on, while maintaining good pen hygiene through easy pen cleaning and good drainage.

Surface

Concrete surfaces are strongly recommended for all covered housing systems. A smooth surface under the bedding area will make cleaning easier, but with non-slip finishing for people traffic areas and where bedding is not applied. *Section 24 – Buildings* provides more information on non-slip concrete surfacing techniques.



Parallel slatted flooring

If underground drainage is installed under the covered pen surfaces, bedding material will not be required as parallel slats will allow urine and manure to pass through the floor surface into the drainage area below. The slats should be covered in a hard plastic or hardened rubber material to ensure adequate softness for cattle and a non-slip surface.

Pen cleaning and bedding management

Bedding

The main purpose of bedding is to provide soft flooring, improve animal comfort and to absorb manure moisture. Bedding is only required in sections of the pen which are covered.

Bedding materials may be categorised as organic or inorganic. Organic materials include straw, hulls (rice/peanut) and sawdust and dry compost (Table 2). Dry bedding should be placed in the pen to a depth of approximately 200 mm and should be removed when it is unable to absorb any further moisture or manure. It is then taken to a manure storage area or directly off site.

An alternative is to install slats with a protective coating over an underground drainage system.

Pen cleaning

Pens will need to be cleaned every two to three weeks depending on the stocking density and type of bedding material used. For covered pens, cleaning involves the removal of spent bedding material along with manure and other solid wastes. An appropriate flooring/bedding system should allow material to be removed mechanically. Uncovered pens that have concrete floors may be washed clean by rainfall, although hosing may be used if necessary.

The ability to clean pens practically and efficiently should be considered in the housing design and pen layout.

If a push-through system is used, a manure/spent bedding stockpile area may be needed at the end of the pen row (Figure 7).

Where parallel slats are installed over an underground drainage system, feeding pens can be cleaned regularly and the drainage system flushed as required or on demand.

Drainage and effluent collection

Runoff from contaminated areas must be directed to the effluent management system. For fully covered housing systems, this will include cattle lanes, manure stockpile areas, livestock handling facilities and feed processing areas, including silage and liquid feedstuffs storage areas. For partially covered housing systems, runoff from the open air pens will also need to be contained within the controlled drainage area.

Drainage slopes for cattle lanes will be similar to those in uncovered feedlots (see *Section 10 - Pen and drainage systems*).

Sedimentation structures will be required only for partially covered pens and will be similar to those in uncovered feedlots (see *Section 11 - Sedimentation removal systems*). Design and construction of holding ponds will be identical to those in open air feedlots (see *Section 12 - Holding pond design*).



Slatted flooring



Sawdust bedding to absorb urine and improve animal comfort

Clean runoff (from roofs and grassed areas) should be excluded from the effluent management system where possible to minimise the required system capacity, with roof runoff able to be stored for reuse

Table 2. Suitability of bedding type for Australian feedlots

Type	Absorbency	Durability	Porosity	Recyclability	Key factors that influence the suitability and uptake of bedding materials
Woodchip (screened chip)	*Avg.	Good	Avg.	Good	More durable than straw and sawdust. Porosity within a woodchip bedded area typically lasts longer than a straw or sawdust bedded area.
Woodchip (Post peeling)	Avg.	Avg.	Avg.	Poor	Larger woodchip pieces can be recycled (i.e. screened from spent bedding). Easier to handle, transport, distribute and remove from feedlot pens than straw. Sharp woodchip pieces assist in removing/wearing dags off cattle.
Corn stubble /straw	Good	Avg.	Good	Poor	Good absorbency and provides softer, more comfortable lying surface for cattle than woodchip. Longer straw particles create a stronger, more durable bedded area that allows better drainage than chopped straw.
Sawdust	Good	Poor	Poor	Poor	Good absorbency and provides softer, more comfortable lying surface for cattle than woodchip. Poor durability once wet/saturated. Longevity reduced through interaction with rainfall.
Rice hull	Poor	Poor	Good	Poor	Rice hulls have good porosity and thermal insulation properties. However, their fluffy nature reduces transport efficiency and makes them difficult to handle.
Almond hull	Avg.	Poor	Avg.	Poor	Almond hulls have average absorbency and porosity, but they may be considered palatable by cattle. Availability and uptake limited to processing locations in north western Victoria and NSW Riverina.
Composted manure	Good	Poor	Poor	Poor	Very absorptive but not considered suitable as a bedding material in Australian feedlots.
Sand	Poor	Avg.	Poor	Avg.	Low porosity reduces its effectiveness and high bulk density makes it expensive to transport. Hard to recycle (unless washed) and can be abrasive on soft hooves.
Recycled rubber chip	Poor	Poor	Avg.	Avg.	No data found on use in cattle feedlots. Potential concerns of heavy metal contaminants from the recycled tyres.
Parallel slats	Poor	Good	Poor	Avg.	Suitable over underground drainage system. Limits moisture and accumulation of spent bedding. Requires underground flushing mechanism to remove urine and manure deposits. Provides enhanced welfare outcomes as feeding pens can be clean(ed) all year round.

Solid waste management

Solid wastes are most easily handled when they are dry. Skid steer loaders are suitable for cleaning pens or sedimentation structures and can load solids into trucks, which then transport the material to storage areas.

Solid waste management systems must have enough capacity to store solids produced from the feedlot as they dry and are further processed for reuse. Reuse or removal (further value-adding or sale) of stockpiled solid wastes will reduce the required capacity of storage systems.

If odour was a reason for adopting covered housing, solid waste material must be kept as dry as possible to limit excessive odour and emissions. The stockpile area may need to be under cover in high rainfall areas.

All storage areas must be located within the controlled drainage area and provide adequate drainage to allow stockpiled solids to drain and dry in the stockpile. Drainage from the storage area must be directed into the effluent management system (see *Section 10 – Pen and drainage systems*).

Quick tips

- Partially covered pens cost less but require effluent control systems.
- The full advantages of a covered housing system are not realised unless the pen area is completely covered.
- Sheds should be designed with high eaves, open sides and open ridge caps along the apex to promote ventilation.
- Roof pitches should be steep enough to promote ventilation. A minimum roof pitch of 5° (1V:12H) is recommended.
- All roof runoff should be collected in gutters and diverted away from the effluent management system.
- A pen depth twice the width allows gates to be installed in the dividing fenceline that can be swung across the pen to temporarily hold cattle for pen cleaning or maintenance.
- Roof support columns should be placed in line with fences.

Further reading

AUS-MEAT, 2011, NFAS Rules & Standards (April 2011), AUS-MEAT Limited, Brisbane, Qld.

Boyles, S., Fisher, J., Fike, G., DiCostanzo, A. and Lamb, C., Facilities and Cattle Handling, Lesson 5 - Stocker Backgrounder Nutrition and Management, University of Minnesota.

DAFF, 2013, Australian Animal Standards and Guidelines for Cattle, Department of Agriculture, Forestry and Fisheries, Australian Government, Canberra, ACT.

Department of Primary Industries Victoria, 2010, Guidelines for Victorian Dairy Feedpads and Freestalls, State of Victoria.

Herbert, S., Hashemi, M., Chickering-Sears, C. and Weis S., (n.d.), Beef Cattle Housing & Equipment, CDLE Pub. 09-48 UMass Extension Crops, Dairy, Livestock, Equine Mass. Dept. of Environmental Protection, s319 Program, USDA-SARE.

MLA, 2006, The South-East Asian Feedlot manual – Module 2 – Feedlot Design, Project W.LIV.0366, Meat & Livestock Australia Ltd, North Sydney, New South Wales.

MLA, 2012a, National Guidelines for Beef Cattle Feedlots in Australia. Meat & Livestock Australia, Sydney, NSW.

MLA, 2012b National Beef Cattle Feedlot Environmental Code of Practice. Meat & Livestock Australia, Sydney, NSW.

MLA, 2009. Management of Bedding during the Livestock Export Process, Final Report W.LIV.0254,. Meat & Livestock Australia, Sydney, NSW.

MLA, 2012, “Is it fit to load?” guide, Meat & Livestock Australia, Sydney, NSW.

Redding, G.J. and Foster, M.P., 1988, Functional Design Handbook for Australian Farm Buildings, Agricultural Engineering Section, Department of Civil and Agricultural Engineering, University of Melbourne.

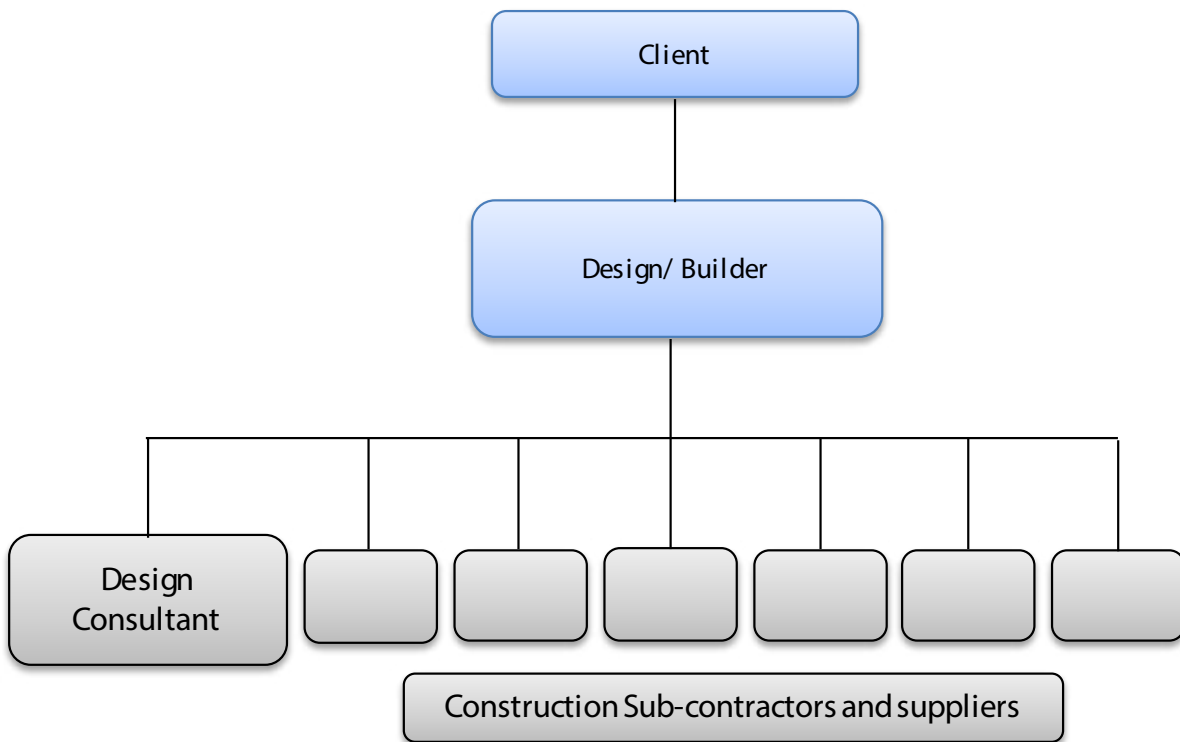

FEEDLOT DESIGN AND CONSTRUCTION

45. Feedlot construction delivery

AUTHORS: Rod Davis and Ross Stafford

Introduction

This section provides a framework to aid lot feeders with the planning, designing and construction of new or upgraded feedlot infrastructure.

The process of delivering a major or minor construction project at a feedlot involves a number of phases and can be complex, as there are usually numerous parties involved with relatively little direct acquisition of individual plant and equipment.

Each phase requires specific tasks to be performed and deliverables to be produced. Some of these, such as plans and specifications, will be needed before obtaining the necessary regulatory approvals to move forward. These tasks, approvals and deliverables combine to create an organised set of process controls.

The phases in the process are outlined in the following table along with the potential parties which may be involved in each phase.

Phases	Tasks	Potential parties involved
Delivery method	Decide the framework for taking the project from concept through to completion. Relationships between the parties (by way of contract), responsibilities and risks of each party are determined at this stage.	Lot feeder, project manager, design consultant, construction contractor, construction subcontractors, suppliers.
Project definition	Scoping, feasibility, schematic design.	Lot feeder, design consultant
Initial project design	Prepare detailed layout and design calculations for the aspects of the project that require regulatory approval.	Lot feeder, design consultant
Project approval	Obtain regulatory approval for the project to proceed.	Lot feeder, design consultant
Detailed design, drawings and technical specifications	Detailed design drawings, Bill of Quantities, technical construction specifications prepared.	Design consultant
Project tendering	The process for procuring construction services.	Lot feeder, design consultant, project manager, tenderers
Project management	Managing the construction process.	Lot feeder, design consultant, project manager or construction contractor.
Construction	Construction activities, project completion, project handover.	Lot feeder, project manager, construction contractor, construction subcontractors, suppliers.
Post construction	Defects period, warranties, post-construction activities (e.g. survey), financial closure.	Lot feeder, project manager, construction contractor, construction subcontractors

One of the first decisions that a lot feeder faces after deciding to undertake a construction project is how to manage the project from concept through to completion.

To ensure maximum efficiency of all elements involved in any construction project, it is important to bring organisation and structure together in the planning, design, estimation and project management phases. The lot feeder must decide if and when to engage a consultant (e.g. designers, project managers) and when to engage the construction contractor.

Each project has its own set of circumstances. These include the project type, scope, complexity, budget and schedule, as well as financing objectives, available resources and the level of lot feeder

involvement and risk. Lot feeders should not underestimate the work involved in managing construction projects and the time that will be taken away from day to day management of the feedlot.

The method of delivery forms the framework for organising the management of the design and construction elements of the project.

The selection of a method of project delivery will determine what parties will be involved in the project, such as the lot feeder, design consultant, project manager, construction contractor and subcontractors, and defines the relationships between each of them.

These relationships, which are usually bound by specific contractual terms, can have wide-reaching effects on the project budget, schedule, quality and the amount of lot feeder involvement required for the project. Within each project delivery method, parties have varying roles and contractual responsibilities.

The different project delivery methods are distinguished by the way the contracts between the lot feeder, consultants (e.g. designers, project manager) and the construction contractors are formed and the technical relationships, responsibilities and the allocation of risk that evolves between each party inside those contracts.

Each project has a delivery method that is optimum for its unique environment and the business conditions in which it must be delivered. Each project delivery method has its advantages and disadvantages. Lot feeders alone or in conjunction with consultants (e.g. design consultant, project managers) must carefully analyse those conditions before selecting the specific method by which a project is to be delivered. Not doing so may lead to contractual disputes, project delays and project cost overruns.

Project delivery methods have evolved to deal with the many ways in which contracting parties wish to allocate their risk, from the traditional stipulated price/general contract, to the development of alternative financing and procurement methods.

Objectives

Selection of a delivery method that is right for each project starts with a clear understanding of the project objectives and constraints. The objectives of the delivery method are to

- select which parties will be involved with the project
- define the roles of various parties
- consider the fair allocation of risks and obligations between the parties
- ensure maximum efficiency for all elements involved in the project
- provide best value for construction costs
- ensure compliance with all WH&S obligations
- ensure the project is completed within time and budget and all contractual obligations are met.

Mandatory requirements

Compliance with

- relevant Commonwealth, state and local authority codes, regulations and relevant Australian standards as applicable to conditions of contract, tendering, project and risk management.
- legal obligations that must be complied with to provide for the health and safety of workers within work health and safety regulations and legislation (Work Health and Safety Act 2011/ Work Health and Safety Regulations 2011).

Delivery methods

Because of financial, organisational and time constraints, various project delivery methods have evolved. Most delivery methods used today are variations of three primary methods.

The three primary methods have their own contract structure and set of characteristics and are:

- Design-Bid-Build
- Design-Build
- Project Management

Design-Bid-Build (the traditional method)

The traditional method is characterised by a linear process where one task follows the completion of another, with virtually no overlap.

A design consultant is selected, and will be responsible for the project's design including detailed drawings, specifications and preparation of the tender documents based on the lot feeder's needs. The design consultant would also prepare a Bill of Quantities or Schedule of Rates. A Bill of Quantities or Schedule of Rates itemises all work for the project including materials, parts, and labour. This document is important as it allows a prospective tenderer to accurately price the work. The design consultant is responsible to the lot feeder for the design of the project.

A tender process follows where tenders are solicited from construction contractors, who then tender for the project works as per the tender documents provided (see *Section 47 – Project tendering*). The project is then awarded to a construction contractor and the design consultant may, to varying degrees, also undertake the supervision, contract administration and certification of the work performed under the construction contract as the lot feeder's representative. The lot feeder is responsible for the details of design and liable to the construction contractor for the quality of the construction contract documents.

The consultant's contract is most often a fixed-price contract with a date-certain construction period. Through the consulting agreement, the lot feeder gains the benefit of the design consultant's experience and expertise. Once the design has been completed and the work offered for tender, the lot feeder will contract the construction contractor, who is wholly responsible for the construction of the project in accordance with the consultant's design. The construction contractor under this delivery method is responsible to the lot feeder and accepts the responsibility and risks for the construction means and methods and for the performance of the various subcontractors that are retained.

This project delivery method is commonly referred to as a Design-Bid-Build project since each of these phases is undertaken separately (Figure 1). Throughout each component of the project, each of the parties will subcontract with various other consultants, suppliers, service providers, in order to fulfil their obligations. The design consultant may subcontract portions of its scope of work to other consultants. For example, environmental, structural, and/or geotechnical engineering services may be required to complete the design tasks for which the consultant was retained. In addition, the construction contractor will retain subcontractors and suppliers of various specialisations who will supply labour and materials to the project e.g. concrete, fencing.

The traditional method is distinguished by the fact there is no construction contractor input during the design phase. The lot feeder must rely on the consultant alone for a constructability review, if there is any at all.

The traditional method creates independent relationships between the consultant and the construction contractor, with each directly responsible to the lot feeder. These relationships create a system of checks and balances that serve to protect the lot feeder from inferior design and construction. Since the consultant acts on behalf of the lot feeder, he protects the interest of the lot feeder in obtaining a project that complies with the project scope, specifications and contract documents. He also has the responsibility of being fair and impartial toward the construction contractor.

Characteristics

- Selection of the construction contractor is typically based on price, experience and qualifications
- Lot feeder and design consultant are responsible for completeness and accuracy of construction documents
- Firm project pricing can only be established after the lot feeder has incurred the majority of the cost for a complete design
- Lot feeder is financially responsible for conflicts among project team members (design consultant and construction contractor) and cost overruns
- Risks are somewhat evenly distributed between lot feeder and construction contractor

This delivery method is best suited for less complicated projects that are budget sensitive but not schedule sensitive, not subject to change, and where the lot feeder can completely control the design.

A busy economy may add to problems with this method. The best construction contractors will not 'gamble' to get work when there are other lot feeders lined up to negotiate contracts. Also, the best subcontractors align themselves with the best contractors. If subcontractors are busy, a construction contractor bid may only partially estimate the work involved. The tender bid may be padded with an extremely high profit margin to cover the possibility that they may have underestimated the actual work. This causes the lot feeder to seek alternative construction contractors who are not as busy and therefore willing to give a better price, but this can often be at a reduced quality of workmanship.



Setting out of works for a new feedlot site

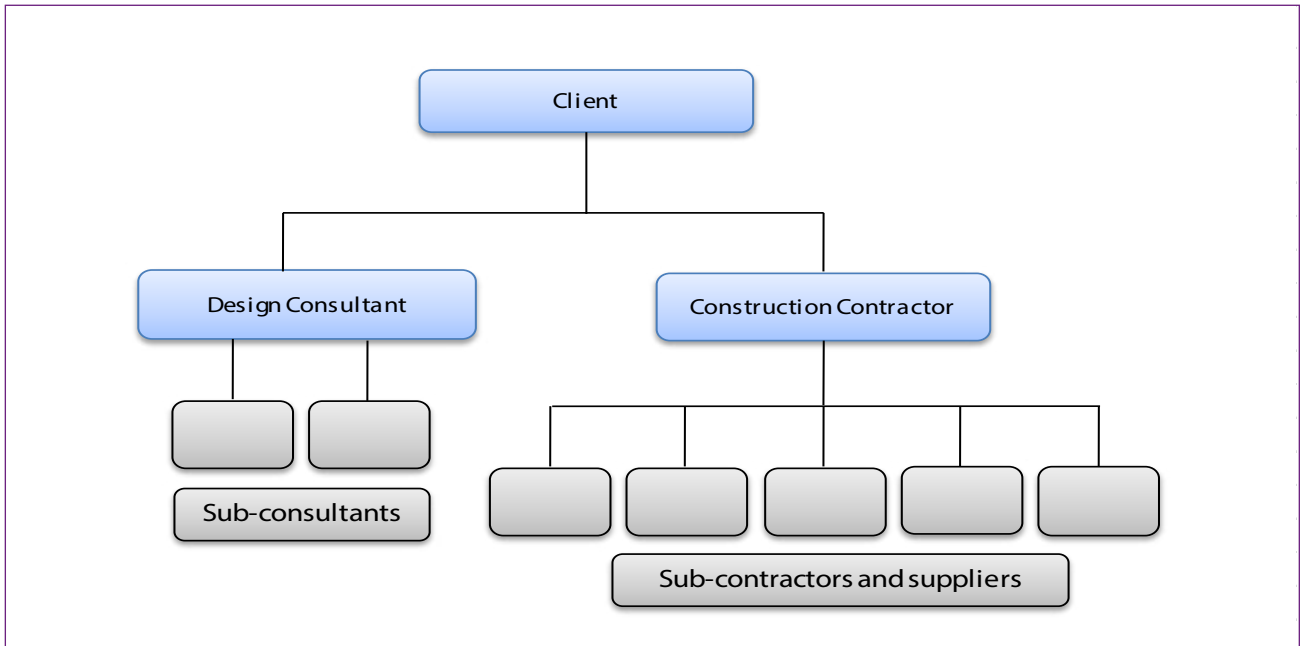

Figure 1. Structure of a Design-Bid-Build delivery method

Advantages	Disadvantages
Familiar delivery method	Can promote adversarial relationships between all parties increasing the probability of disputes
Competitive bidding is used to achieve the lowest price for the scope of works	Typical project duration is longer than all other delivery methods due to linear process
Simpler process to manage	No construction input during design and this may cause issues with cost savings and alternative methods
Fully defined project scope for both design and construction	Price not established until bids are received; may require redesign and rebid if bids exceed budget
Both design team and contractor accountable to lot feeder	Cost estimates can change during the design process
Creates the most bidding opportunities for construction contractors and subcontractors	Not optimal for projects that are sequential, schedule or change sensitive
Pricing is developed competitively, and can result in the 'best price'	Change orders and claims may increase final project cost
Design consultant assists less experienced lot feeder	

Design-Build or Design-Construct

Design-Build is a project delivery method in which the lot feeder procures both design and construction services in the same contract from a single, legal entity (or consortium). The entity is referred to as the design-builder. The design-builder is retained by the lot feeder to deliver a complete project, inclusive of design services. There are a number of variations on the Design-Build delivery method, but all involve three major components (Figure 2).

Firstly, the lot feeder develops (with or without the aid of a design consultant) a project brief. The project brief will define the lot feeder's project requirements and will typically include the functional, performance, quality and design life requirements. The

project requirements will also include any constraints on the design, such as land acquisition, approvals and the like.

Next, the lot feeder (with or without the aid of a consultant) calls for tenders and evaluates tenders of those offering proposals. Finally, with evaluation complete, the lot feeder must engage in a contract with the accepted tenderer on a fixed price basis for both design and construction services. The contracted Design-Builder carries out the design using its own designer.

The Design-Builder is liable for all design and construction costs and normally must provide a firm, fixed price and delivery schedule in its tender. The Design-Builder may award a proportion of the project to subcontractors.

From the lot feeder's perspective, the project's chain of responsibility has been considerably simplified. The construction contractor has early constructability input to the design process which is an advantage. The Design-Builder literally controls this project delivery process. As a result, Design-Build is the delivery method which has the greatest ability to compress a project delivery period and as a result is often used for 'fast-track' projects.

Characteristics:

- Design-Builder team selection is based on qualifications, experience and individual team members
- Collaborative team approach
- Lot feeder responsible for variations in project scope.

This type of delivery method is best suited for new construction projects that are highly time sensitive, projects with smaller user groups or reduced need for user reviews and mid-course design changes.

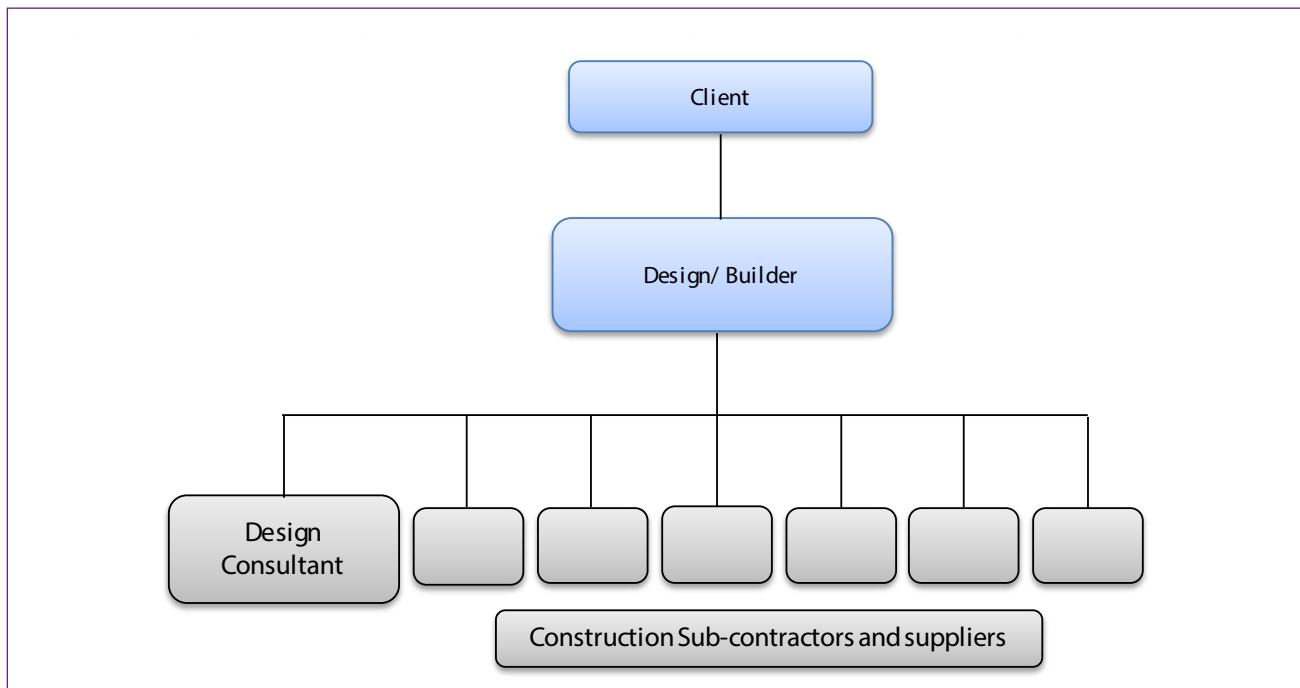

Figure 2. Structure of a Design-Construct delivery method

Advantages	Disadvantages
Fixed cost	Difficult for lot feeder to determine whether the best price and quality has been achieved for the work
Reduced claims/change-orders. Decreased opportunities for claims compared to separate design and construct responsibilities.	Initial costs are likely to be higher than traditional delivery methods due to increased contractor risk, reduced competition in pricing of contractor overhead, fee and subcontract costs
Guaranteed contract value can be established early in the process	Changes during the project can be difficult and expensive to make once construction begins, due to phased construction and cost driven, inflexible budget
Fastest project completion when compared to other delivery methods (design and construction activities can overlap)	Lot feeder must have a clear idea and definition of scope and concept before selection of Design-Builder.
Lot feeder looks to one entity for responsibility of design and construction and project performance	Lot feeder has no input on selection of proposed design team
Price tends to match quality	Over-emphasis on price may compromise quality
The lot feeder benefits from early construction input during design, budget and planning phases (value-engineering, innovation, constructability review)	Increased speed and fewer reviews increase potential for mistakes, missed items etc.
No variations for errors and omissions	No check and balance between contractor and designer
Most of the project is competitively bid	Lot feeder left to fend for himself versus the Design-Builder, creating potential for reduced quality and increased potential for conflict between lot feeder and Design-Builder
Lot feeder's contract administration and site representative risks and costs are reduced, since the Design-Builder is responsible for all coordination efforts	Once the contract is issued, lot feeder relinquishes control of the selection of the contractors used in the detailed design and construction process

Project management

The Project Management method of project delivery allows the lot feeder to engage the services of a professional project manager to manage the construction process but accepts some risk and reward on the cost outcomes (Figure 2). The Project Manager represents the lot feeder in overseeing the activities of the contractor(s) performing the construction on site.

First, a design consultant is selected, who is responsible for the project's design including detailed drawings and specifications and preparation of the tender documents based on the lot feeder's needs. The consultant would also prepare a Bill of Quantities or Schedule of Rates. A Bill of Quantities or Schedule of Rates itemises all work for the project including materials, parts, and labour. The design consultant team may report directly to the lot feeder and project manager.

The greatest benefits are obtained when the project manager is employed during the project planning and design process. In this capacity, project management assistance is provided to the lot feeder prior to construction, offering schedule, budget and constructability advice. This may result in advantageous changes to the project.

Depending on the circumstances and the lot feeder's ability to assume risk, the project manager might be assigned as 'Agent for' the lot feeder, with clearly defined areas of authority for committing the lot feeder financially, authorising payments, proactively negotiating and approving changes and resolving disputes.

In some cases the project manager might be asked to manage the project 'at risk', meaning that at some point in the project, the project manager would be required to agree to a not-to-exceed price for the work (Guaranteed Maximum Price – GMP), thus again providing a level of financial protection for the lot feeder. That is, the project manager holds the risk of construction performance and guarantees completion of the project for a negotiated price which is usually established when the design is somewhere between 50% and 90% developed. The final construction price is the sum of the project manager's fee, overhead and contingencies and the subcontractors' proposals. Any unused contingency at the end of the project reverts to the lot feeder.

The Project Management method is a fast track method. This enables the project manager to tender and subcontract portions of the work with an approved design and commence construction while the design and documentation of unrelated portions are being finalised.

The project manager does not employ the actual construction subcontractors, only approves their work and payments. The subcontractors are actually under direct contract with the lot feeder and not the project manager. Contracts are awarded to subcontractors based on their submitted tenders (see *Section 47 – Project tendering*).

The Project Management method is useful in volatile economic and industrial climates by helping to reduce the time and cost of project delivery. The lot feeder can modify specifications of later portions of work according to changing project requirements.

The largest setback to this method is construction responsibility after the project's completion. Since the subcontractors are paid directly by the lot feeder, they are each individually responsible to the lot feeder. This removes a single source of responsibility for construction defects during the warranty period. If a problem arises, the lot feeder must find the subcontractor and obtain a warranty correction. Typically, the lot feeder lacks the leverage a construction contractor would have in obtaining this warranty work from subcontractors.

Characteristics

- Fewer changes required once construction begins
- Best suited for large new or renovation projects that are schedule-sensitive, difficult to define or subject to potential changes; also for projects requiring a high level of construction management due to multiple phases, technical complexity or multi-disciplinary coordination.

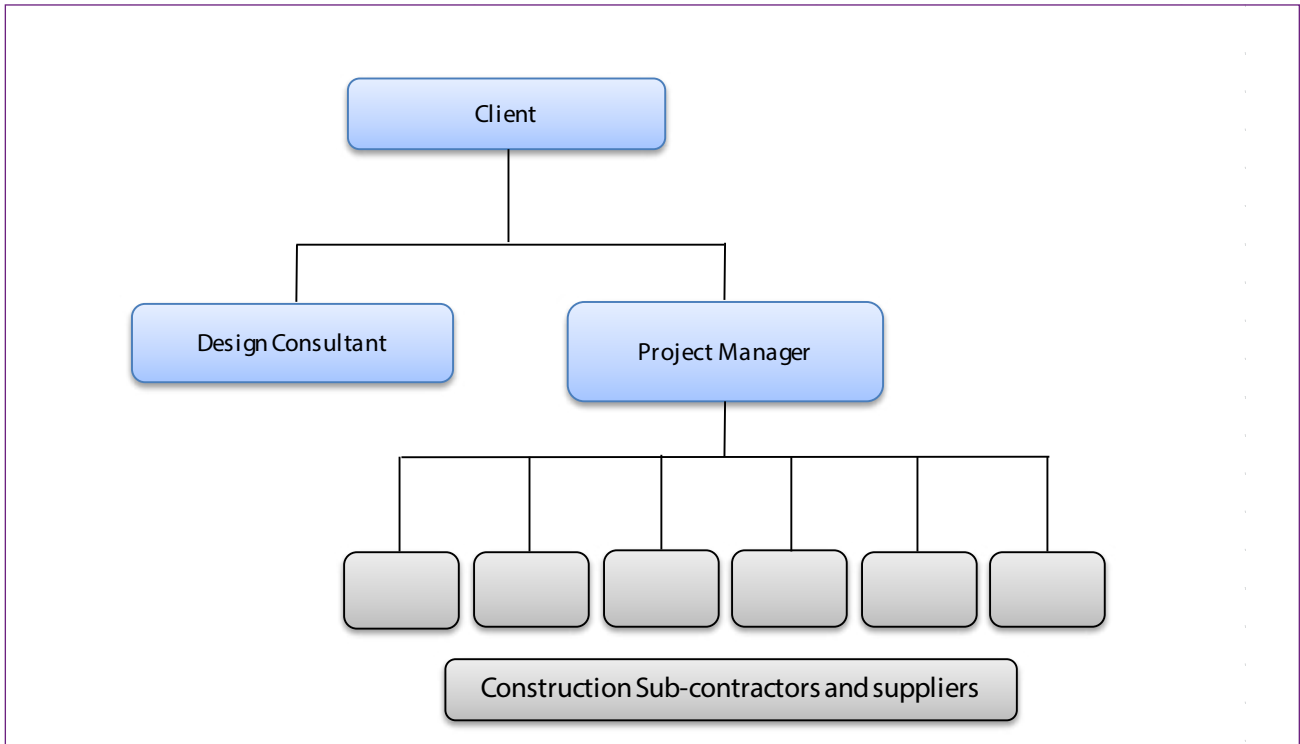

Figure 3. Structure of a Project Management delivery method

Advantages	Disadvantages
Selection of project manager based on qualifications, experience of individual team members	Difficult for lot feeder to evaluate the GMP or determine whether the best price has been achieved for the work
Project manager can provide design phase assistance for budget, project planning, and value-engineering analysis	Costs more than traditional bid due to reduced competition in pricing of contractor overhead, fee and subcontract costs
Continuous budget and schedule control/feedback possible	Costs often increase due to 'details' not in the GMP
Faster schedule than traditional bid; fast track construction possible	Project manager may inflate the budget to cover potential cost overruns
Theoretically, more teamwork between design consultant and project manager	Conflict between subcontractors may still be a problem even though they are coordinated by a project manager
Provides more ability to handle change in design and scope	Lot feeder must deal with post construction warranty issues
Theoretically, reduced changes and claims once in construction	
Lot feeder may be less experienced in project management and time constrained	

Quick tips

- The project delivery method must be selected very early in the life of a project.
- Identify stakeholders and resource constraints, and seek specialist guidance
- Match project/lot feeder needs/characteristics to delivery method for characteristics/risks/benefits
- A project delivery method should be selected that will best suit the project and maximise the benefits obtained from the expertise involved
- It is important to understand that the responsibilities and risks performed during the phases of a project differ amongst the various parties, depending upon the method implemented
- Have a contract system in place for each of the elements involved in the chosen project delivery method

Further reading

Standards Australia 2010, *General Conditions of Contract for Consultants*, (AS 4122 – 2010), Standards Australia, Sydney, NSW.

Standards Australia 1993, *Subcontract conditions*, (AS 2545 – 1993), Standards Australia, Sydney, NSW.

Standards Australia 1994, *User's manual for lump sum contract*, (SAA HB57 – 1994), Standards Australia, Sydney, NSW.

Standards Australia 1992, *General conditions of contract*, (AS 2124 – 1992) – Annexure Part A, Standards Australia, Sydney, NSW.

Standards Australia 1992, *General conditions of contract*, (AS 2124 – 1992) – Annexure Part B, Standards Australia, Sydney, NSW.

Standards Australia 1994, *Code of tendering*, (AS 4120 – 1994), Standards Australia, Sydney, NSW.

Standards Australia 2005, *Project Management – General Conditions*, (AS 4915 – 2002/Amdt 1-2005), Standards Australia, Sydney NSW.

Standards Australia 2005, *General conditions of contract*, (AS 4000 – 1997/Amdt 3-2005), Standards Australia, Sydney, NSW.

Standards Australia 2002, *Construction Management – General Conditions*, (AS 4916 – 2002), Standards Australia, Sydney, NSW.

Standards Australia 2000, *General Conditions of contract for design and construct*, (AS 4902 – 2000), Standards Australia, Sydney, NSW.

Standards Australia 2002, *Minor works contract conditions (Superintendent administered)*, (AS 4905 – 2002), Standards Australia, Sydney, NSW.

Standards Australia/Standards New Zealand ISO (2009). *Risk management - Principles and guidelines*. (ISO 31000:2009). Sydney, NSW, Standards Australia.

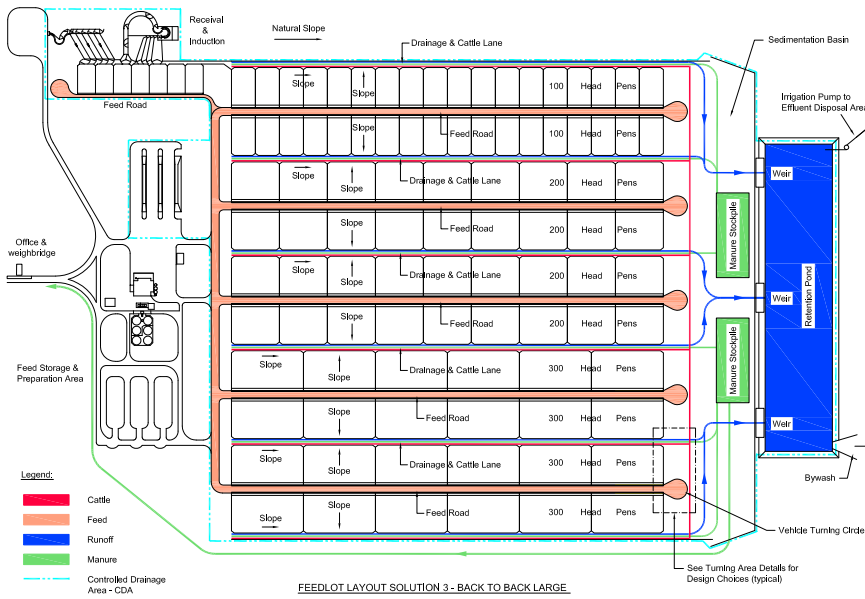

FEEDLOT DESIGN AND CONSTRUCTION

46. Design drawings and technical specifications

AUTHORS: Rod Davis and Ross Stafford

Introduction

Design documentation is prepared to a level that allows the works to be constructed accurately. The design documentation includes design drawings, bill of quantities and technical specifications.

Design drawings are developed to a level of detail necessary to prepare a clear, coordinated visual depiction of all aspects of the works. Major project elements including overall layout, earthworks equipment, mechanical, electrical, structural, and water supply systems are designed and depicted through coordinated scale drawings and detailed elevations and plans. The lot feeder may engage consultants to ensure well-coordinated drawings and bill of quantities are prepared.

Technical specifications are prepared to provide consistency and to instruct construction contractors on how the works are to be carried out, the quality of the workmanship and methods of quality assurance for the construction. Technical specifications describe the project design and construction practices, technical standards, specifications and principles to be followed during construction.

Technical specifications may specify a performance goal (a performance specification) or procedures used to meet the performance goal (design specification). A performance specification permits flexibility and change. For example, a performance specification for a feed processing system may specify that the capacity be a nominated tonnes per hour at a particular standard of quality.

In general, the scope and detail of technical specifications will depend on the nature and complexity of the project. Technical specifications should form part of all construction projects.

The level of adherence to the design drawings and technical specifications ultimately determines the quality of the project and influences the performance of the constructed works.

Objectives

The objectives of the design drawings and technical specifications are to

- provide a detailed record of the design of the project
- set standards for the technical aspects required in the construction
- set standards for the execution of the construction
- set standards for documenting the design, tendering and construction process.

Mandatory requirements

All work performed pursuant to specifications shall comply with the requirements of the relevant local Acts, Regulations, Standards and Codes of Practice of all authorities having jurisdiction over the work.

Technical data

The design drawings and technical specifications should include

- Design drawings – these set out design information and procedures which are required to be used on the works.
- Bill of Quantities – this itemises the quantity of materials to enable a tenderer to accurately cost the work for which they are bidding.
- Material specifications – such as diameter, type and grade of material for pipes (e.g. polyethylene pipes or UPVC), joining methods (e.g. electro-fused or compression fittings etc), or 28-day compressive strength of concrete.
- Requirements for Material Testing e.g. testing required for earthworks (i.e. minimum required compaction and moisture range to be achieved), frequency of testing (e.g. one soil density test per 1,000 m³ of bulk earthworks) or the number of tests per 1,000 m² of area for hydraulic conductivity tests in sedimentation ponds.
- Construction and installation methods.
- Development approval conditions that have to be complied with throughout the construction.

Design documents

Design documents relate to the design, construction and commissioning of the project works. Typically, the documents should include

- design drawings
- construction specifications

Design drawings

Design drawings for construction contain all the information necessary for the construction contractor to bid on and build a particular project. Typically, the preparation of design drawings provides a detailed record of the design and structural requirements of the works. A contract or tender document often references design drawings.

Design drawings should show details on layout, measurements, plan, cross-sectional and vertical profiles. This information is prepared as scale drawings of the works to be constructed.

Design drawings should be presented in such a way that

- the project can easily be understood
- they visually communicate the concept to the lot feeder and the construction contractor
- they are legible
- they include all information from previous revisions and updates.

The design drawings should include the following aspects

- site layout and the location of the works to be constructed
- plan views

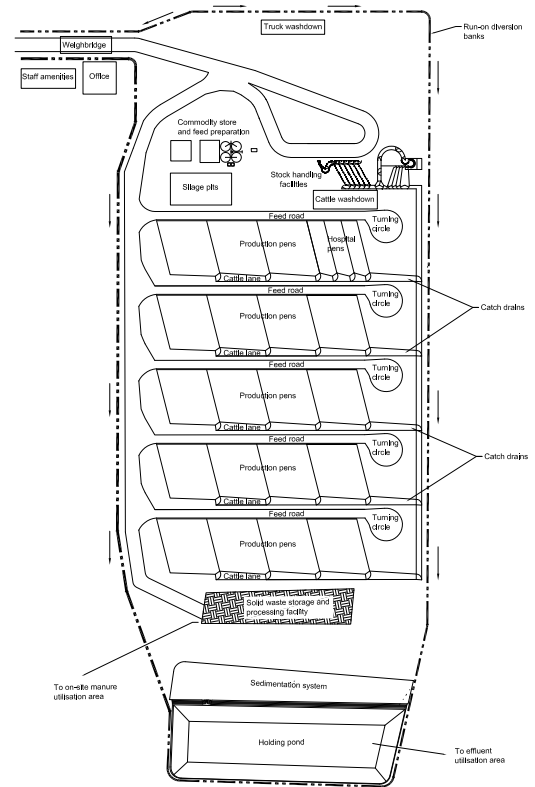

Plan of controlled drainage area for a feedlot

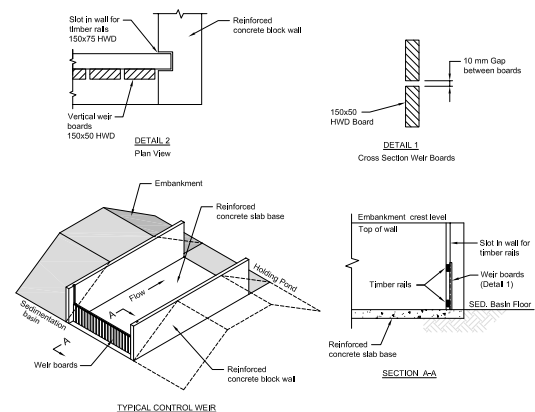

Plan of typical vertical timber weir

- detailed designs and cross-sectional profiles of the works
- dimensions and units gradients
- titles and scales that meet the required standards and units
- adequate labelling
- elevations that are referenced to metres Australian Height Datum (m AHD)
- be dated and signed by the designer.

The lot feeder should ensure that all parties responsible for the creation, processing or supply of drawings and diagrams standardise the layout and content of these drawings. This will preclude the need to incorporate specific instructions on the engineering content of drawings and diagrams in project documentation and other specifications.

To define the content of design drawings and standardise the approach and terminology used, drawing specifications may be followed. Various standards and codes of practice have been prepared to guide engineers and drafters on technical drawings and these are detailed in Table 1.

The adoption of a drawing standard into a design shall be accompanied by a statement of compliance for that standard, confirming that the drawings are fit for purpose and meet all current legislative and Australian Standards requirements. This shall be accompanied by all design calculations as required to confirm compliance.

Computational devices and computer aided drafting and design (CADD) packages have made the creation of project design information in digital form commonplace. Construction machine guidance is now a widely adopted tool in the construction industry, particularly in earthwork operations, due to its accuracy and ease of use. This is an important consideration for the transfer of engineering design data in electronic form for import into these global positioning system (GPS) guidance software and systems.

This approach is a new paradigm of project delivery and requires a move from a 2D view paper-based process to a 3D electronic-based model. Hence, it is important to facilitate construction contractor access to electronic project design files. Typically, real time kinematic (RTK) GPS-based construction equipment guidance systems require input data from a 3D model of the existing and planned surfaces topography, to allow horizontal and vertical control.

This requires that all parties are responsible for the creation, processing or supply of drawings and diagrams, document details of the software, hardware and process solutions that are used. Most importantly, this includes clarification of the interface hurdles between companies and systems.

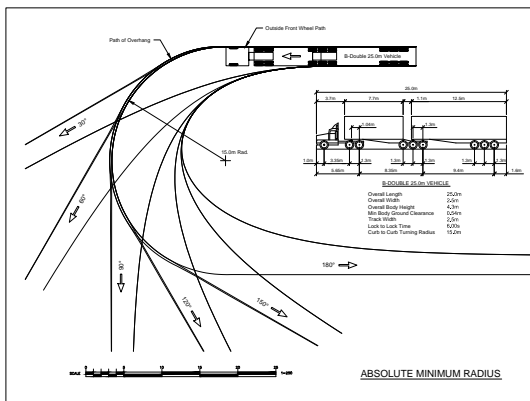

Plan of swept path for B-double truck

Table 1. Relevant Australian and International Standards and Codes of Practice

Document NO.	Document title
AS1100	Technical drawing 1100.101 Part 101: General principles 1100.201-1992 Technical drawing - Mechanical engineering drawing 1100.301 Part 301: Architectural drawing 1100.401 Part 401: Engineering survey and engineering survey design drawing 1100.501 Part 501: Structural engineering drawing
AS1101	Graphical symbols for general engineering 1101.1 Part 1: Hydraulic and pneumatic systems 1101.3 Part 3: Welding and non-destructive examination
AS1102	Graphical symbols for electrotechnical documentation 1102.101: General information and general index 1102.102: Symbol elements, qualifying symbols and other symbols having general application 1102.103: Conductors and connecting devices 1102.104: Basic passive components 1102.105: Semiconductors and electron tubes 1102.106: Production and conversion of electrical energy 1102.107: Switchgear, control gear and protective devices 1102.108: Measuring instruments, lamps and signalling devices 1102.109: Telecommunications – Switching and peripheral equipment 1102.110: Telecommunications – Transmission 1102.111: Architectural and topographical installation plans and diagrams
AS2536	Surface texture
AS ISO 128.1-2005	Technical drawings – General principles of presentation – Introduction and index
AS ISO 128.20-2005	Technical drawings – General principles of presentation – Basic conventions for lines
AS ISO 128.21-2005	Technical drawings – General principles of presentation – Preparation of lines by CAD systems
AS ISO 128.22-2005	Technical drawings – General principles of presentation – Basic conventions and applications for leader lines and reference lines
AS ISO 128.23	Technical drawings – General principles of presentation – Lines on construction drawings
AS ISO 128.24	Technical drawings – General principles of presentation – Lines on mechanical engineering drawings
BS 1553 Parts 1-3	Specification for Graphical Symbols for General Engineering
HB 3-1996	Electrical and electronic drawing practice for students
HB 20-1996	Graphical symbols for fire protection drawings
HB 24-1992	Symbols and abbreviations for building and construction
ISO 14617 Parts 1-11	Graphical symbols for diagrams



Specifications ... for soil testing



... for earthworks



... for concrete works

Technical specifications

A contract or tender document often references technical specifications about the specific requirements and construction standards for various elements of a project. This includes how the work will be done, the quality of workmanship and methods of testing. Typically, construction projects require construction of various elements and use of various materials. More than one technical specification may be required for the whole project. For example, a construction project may require individual technical specifications for

- earthworks
- erosion and sediment controls
- concrete works
- fencing
- building works
- roads
- electrical systems
- water reticulation systems.

For small projects, the material and construction specifications may be documented in the form of notes on the design drawings. For larger projects, a separate specification document is more practical.

Designers will usually have suitable standard technical specification documents. However, as a guide a specification might include

- descriptive title, number, identifier etc. of the specification
- date of last effective revision and revision designation
- a logo or trademark to indicate the document copyright, ownership and origin
- Table of Contents (TOC) if the document is long
- person or office responsible for questions on the specification, updates and deviations
- the significance, scope or importance of the specification and its intended use
- terminology, definitions and abbreviations to clarify the meanings of the specification
- references and Standards used or to be complied with
- test methods for measuring all specified characteristics
- material requirements: physical, mechanical, electrical, chemical
- targets and tolerances
- acceptance testing, including performance testing requirements and tolerances
- workmanship
- certifications required
- safety considerations and requirements
- environmental considerations and requirements
- approval authority considerations and requirements
- quality control requirements, acceptance sampling, inspections, acceptance criteria
- person or office responsible for enforcement of the specification
- completion and delivery
- provisions for rejection, reinspection, rehearing, corrective measures

A typical Table of Contents for an earthworks and concrete specification is shown below.

Earthworks specifications	Concrete work specifications
Scope of works	Extent of work
Description of the work	Code requirements
General specifications	Supervision
Interpretation of terms	Inspection
Geotechnical information	Steel reinforcement
Tolerances	Supply of concrete
– the need for tolerances	Quality of concrete
– edges and alignments	Stabilised sand
– earthworks quantities	Preparation of other than rock surfaces before placing concrete
– setting out	Concrete blinding layer
Site preparation	Formwork
– topsoil stripping	Formwork ties
– topsoil stockpiles	Preparation of formwork surfaces before placing concrete
Cuttings	Placing of concrete
– stockpiling topsoil	Pumping
– excavation	Finish of concrete surfaces
– batter tolerances	Curing of concrete
Benching	Sampling and testing
– transition from cut to fill	Rejection of concrete
Spoil	Removal of formwork
– unsuitable material	Construction joints
Embankment construction	Core holes and building-in
– suitable material	Anchor bolts
– placing fill	Joint fillers
– borrow	Joint sealers
– compaction and quality control	Tolerances for slab surfaces
– compaction and moisture requirements	Special placing conditions and special mixes
– test locations	– concreting in hot weather
Completion	– concreting in windy conditions
References	– concreting in cold weather

Technical specifications may specify a performance goal (a performance standard) or procedures used to meet the performance goal (design standard). A performance standard permits flexibility and change. For example, a performance specification for a feed processing system may specify that the capacity be a nominated tonnes per hour.

Quick tips

- Technical specifications are an integral and important component of a construction project.
- For small projects, the material and construction specifications may be documented in the form of notes on the design drawings.
- For larger projects, the preparation of a separate specification document is more practical.
- Ensure adherence to the technical specifications as this determines the quality of the project and influences the performance of the constructed facility.
- Ensure that all parties responsible for the creation, processing or supply of drawings and diagrams standardise the layout and content of all drawings.
- Ensure that electronic design data is compatible with construction contractor GPS-based machine control systems.

Further reading

Numerous Australian Standards have been developed for the building and construction industry.

Australian standards for technical drawing can be found at www.saiglobal.com

A number of the building and construction standards are referenced in regulations, including the Building Code of Australia, which means it is compulsory to undertake work in the way in which it is specified.

Australian Building Codes Board, 2013, National Construction Code (NCC) Volume 1, Volume 2 and Volume 3. Australian Building Codes Board.

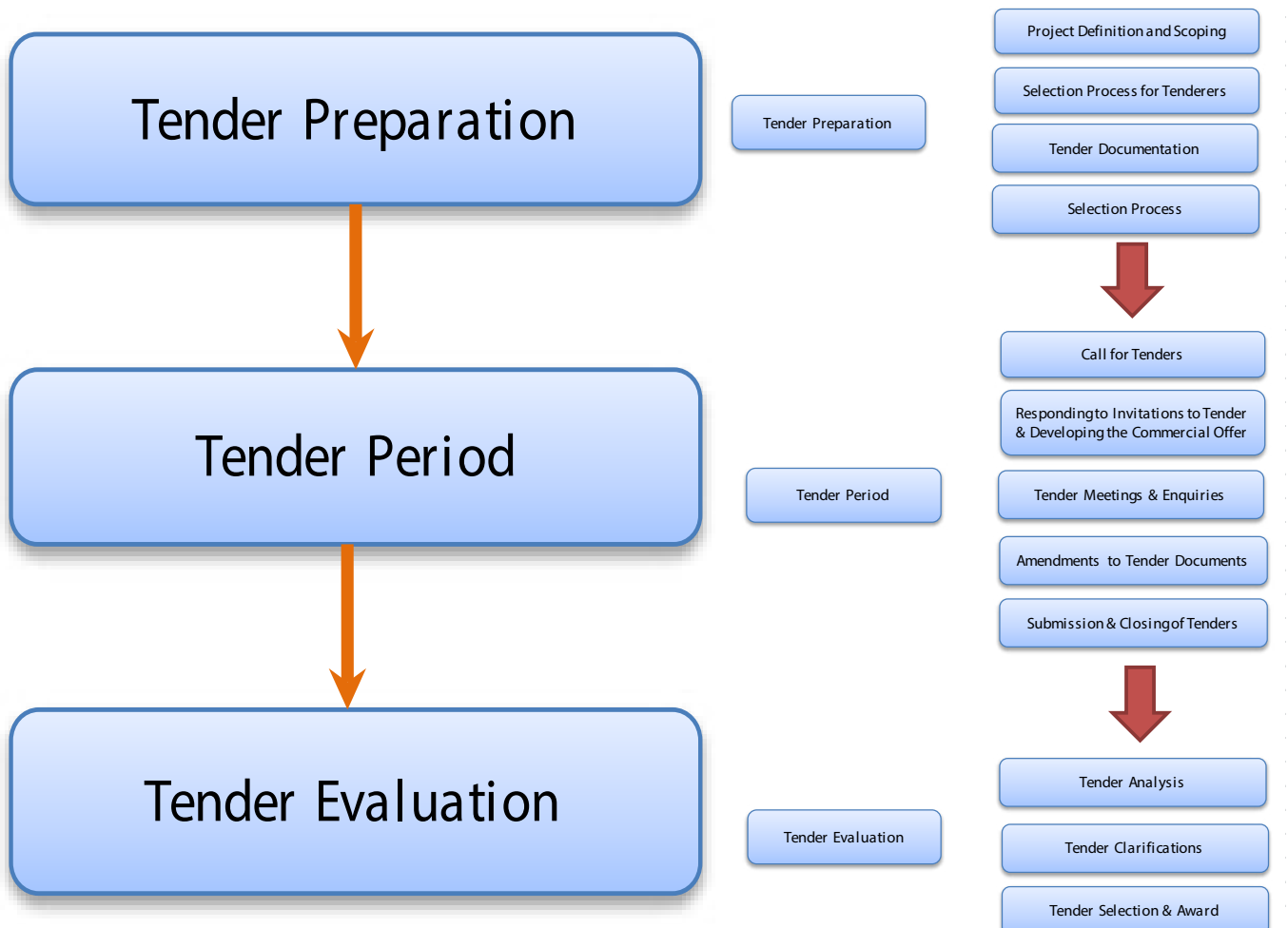

FEEDLOT DESIGN AND CONSTRUCTION

47. Project tendering

AUTHORS: Rod Davis and Ross Stafford

Introduction

When a lot feeder is seeking to have construction works carried out, some form of procurement process will be involved. There are a variety of different methods for procurement, all of which can be used for some level of construction works.

Project tendering is the process by which bids are invited from interested construction contractors to carry out specific packages of construction work. It is a common procurement method to obtain construction services. The tendering process is an important means by which a fair price and best value for undertaking the works is obtained.

Lot feeders should aim to obtain value for money whenever they procure construction services. This requires clear project definition and selection of the best delivery method for the project (See *Section 45 – Feedlot construction delivery*) before embarking on the tendering process.

The tendering process should adopt and observe the key values of fairness, clarity, simplicity and accountability, as well as establish the concept of apportionment of risk to the party best placed to assess and manage it. The principle of tendering is to ensure that true competition is achieved, and tenders received are evaluated by applying certain criteria. These criteria may be expressed in terms of financial matters, comprising a simple assessment relating to tender sums, or more complex financial evaluation, including consideration of projected costs over the life cycle of the completed project. It can also address other non-financial factors such as time, proposed methods, levels of capability; or sometimes a mixture of all these criteria. All tenderers should be able to bid on an equal basis, meaning that they must receive the same information and, most importantly, this information should be sufficient in content and accuracy to allow them to properly assess the implications of the project and bid accordingly.

The tendering process is not always easy, and every activity in the tendering process has a time and cost implication. Therefore, it makes economic sense not to overburden the tenderers with unnecessary information requirements, and to concentrate on those which are relevant to the work which is to be undertaken. Faced with competing financial pressures most construction contractors will carry out their own assessment of the projects for which they wish to tender, and will be less inclined to bid for those where the procedures involved are perceived as overly complicated or onerous. Also, since preparation costs are included in their overheads, these will ultimately be passed on in the form of higher prices.

Tendering can also be used for the procurement of plant and equipment not associated with a construction project.

Project tender objectives

The objectives of the tendering process are to

- provide an environment that encourages interest and competitive offers from suitably qualified and experienced construction contractors

- obtain a fair price and best value for undertaking construction works
- obtain a clear understanding of the rights and obligations of all parties
- allow resolution of general issues requiring clarification to all tenderers
- allow resolution of specific matters only relevant to a particular tenderer's bid
- reduce the likelihood of misunderstandings and disputes during the construction phase
- secure a construction contractor to undertake and meet the required project scope, time, cost and quality parameters.

Mandatory requirements

All project tenderers must comply with the Competition and Consumer Act 2010. The Australian Consumer Law prohibits anti-competitive practices, also referred to as restrictive trade practices, by businesses or individuals.

Ethical standards

It is mandatory that tenderers do not engage in any uncompetitive behaviour including, but not limited to, the following

- agreement between tenderers as to who shall be the successful tenderer and the payment of unsuccessful tender fees
- payment to any third party of monies, incentives or other concessions which do not relate to the provision of bona fide services relevant to the object of the tender, contingent upon the success of the tender
- acceptance or provision of secret commissions
- submission of cover tenders (i.e. tenders submitted as genuine but which have been deliberately priced and structured in order not to win the contract or commission)
- entering of any improper commercial arrangements with any other contractors, subcontractors, suppliers, agents or any other party
- seeking to influence contract decisions by improper means
- acceptance of incentives to provide contracts or services to other contractors, subcontractors or suppliers that financially disadvantage the lot feeder.

Project tendering choices

There are a variety of approaches in which a lot feeder may approach the market and conduct the tender process. These include

Call for Registration (CFR) - A Call for Registration is an approach to market used by a lot feeder to seek details about potential suppliers of a good or service.

Expression of Interest (EOI) - An Expression of Interest is used primarily to determine the market's ability or desire to meet the lot feeder's procurement need, after which the lot feeder may need to collect additional information to make procurement decisions. An

EOI is not an invitation to bid, is not binding on either party and is usually followed by a selective Request for Tender based on a more detailed specification.

Request for Information (RFI) – A Request for Information is commonly used on major procurements particularly if the lot feeder’s requirements could potentially be met through several alternate means. A RFI is not an invitation to bid, is not binding on either party and in some circumstances may be followed by a selective RFT, RFP or RFQ.

Request for Quotation (RFQ) – A Request for Quotation is used when detailed specifications of a good or service are known and competitive bids are to be evaluated, mainly on price.

Request for Proposal (RFP) – A Request for Proposal is used to directly purchase goods or services when the lot feeder clearly understands its business needs but does not have defined details of the solution. This approach is often used for the procurement of professional services.

Request for Tender (RFT) – A Request for Tender is used when a lot feeder is seeking potential suppliers for a scope of work that has been designed and specified in detail. A RFT is often used for building and construction works, plant and equipment and evaluation is based on price and a range of technical factors. This approach is outlined in detail below.

Possible solutions

Typically, the formal RFT process involves three stages which are universally applicable as outlined in Figure 1.

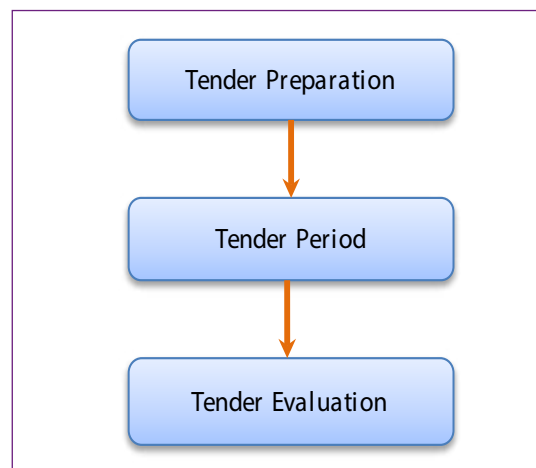

Figure 1. Stages in request for tender process

Each stage has component activities as outlined in the process flow chart in Figure 2. A brief outline of each activity follows.

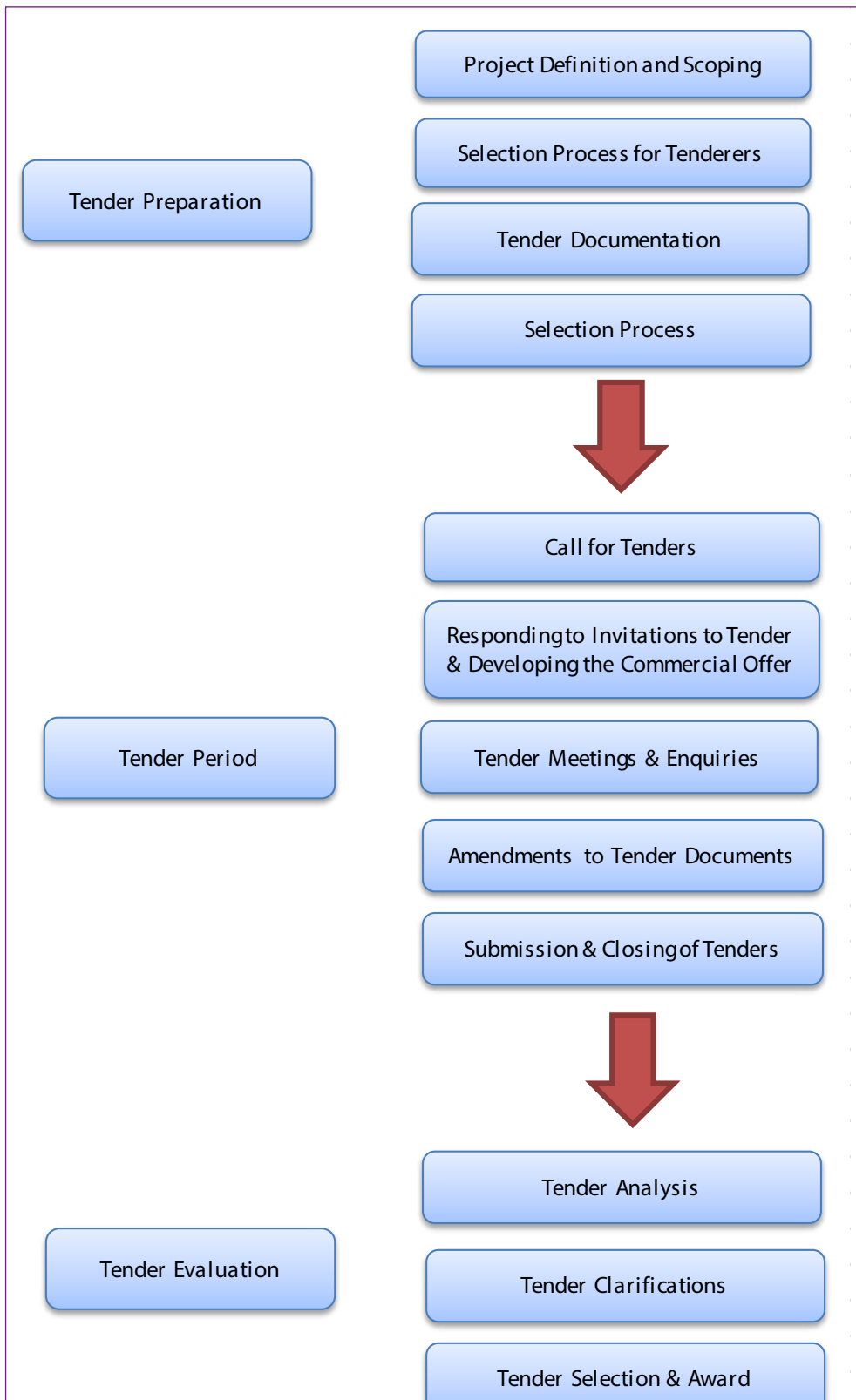

Figure 2. Process flow for tender process activities

Project definition and scoping

The commencement of the Request for Tender (RFT) is the development of the project definition and scope which will set the scene for the success of the entire process. In the best interests of the project, it is recommended that the lot feeder ensures the following

- A Project Brief is prepared that clearly defines the scope of the project for which Tender Documents are to be prepared. This document must define all project requirements (including envisaged functional goals, performance, technical criteria, completion dates or term date requirements) for the project. Any known constraints associated with the delivery of the contract should be identified up front (e.g. public access requirements, availability of land, limits to work, approval conditions). Failure to include all scoping requirements may result in expectations not being met, and disputes or increases in cost at a later date.
- A cost estimate is established based on the scope defined in the Project Brief, which should include the proposed risk allocation between the lot feeder and the tenderer. Costs need to be estimated for all resources associated with the project (including labour, materials and supplies). In this way, the proposed scope may be adjusted in line with the budget.
- A time estimate is established based on the scope defined in the Project Brief. This involves the definition, sequencing and duration estimation of individual project activities.
- A cost/benefit exercise is carried out, taking into account the initial cost estimate, time estimate and expected costs/revenues over the life of the project.
- An appropriate budget is allocated and finance arranged to develop the project.
- Appropriate time is allowed to undertake these activities.

Selection process

The four main processes for the selection of tenderers are outlined in Table 1.

Tender documentation

The content of the tender documentation will vary for particular projects according to factors such as project size, complexity and delivery method. The documents will contain the evaluation criteria, the evaluation procedures and the proposed timing of the evaluation process as outlined in Table 2.

Cost of tender documents

The cost of printing tender documents can sometimes be quite high. A document fee to cover printing costs is sometimes charged, or a refundable deposit is charged to encourage the return of complete and undamaged sets of tender documents.

The amount of any document charge or refundable deposit and the conditions for return of deposits must be clearly stated in the tender advertisement.

Table 1. The selection process

Selection process	Description	Examples
Open or public tenders	The lot feeder invites tenders by way of public advertisement without restriction on the number of tenders received.	Simple projects that are low risk and low cost.
Selected/ approved/invited tenderers	The lot feeder invites a select number of tenderers for a particular project. In some cases, the lot feeder will have an established register of approved contractors for particular types of work. In these cases, tenderers have a recognised capability to undertake the type of project planned. Tenderers are generally invited on a rotational basis. The register of contractors needs to be reviewed and updated on a regular basis.	Repetitive works regularly carried out by a lot feeder. Specialised projects.
Pre-qualified tenders	The lot feeder invites expressions of interest by way of public advertisement for pre-qualification for a specific project or specific types of projects. Evaluation is carried out against the defined selection criteria. A selected number of pre-qualified tenderers is then invited to tender.	Complex projects that are high risk and high cost.
Direct negotiation	The lot feeder negotiates with a single tenderer.	Highly specialised projects in which only one entity has the required skill and current capacity to undertake the work.

Table 2. Tender documentation

Document type	Description
Notice to tenderers	This document contains a project summary, a listing of tender documents relating to the project, key dates, validity period of the tenders submitted, contact details, number of copies of the tender required and details of tender submission location and timing.
Conditions of tendering	This document details the overall tender process including the delivery method, probity issues, communication issues, the criteria for selection and the evaluation process.
Tender form and schedules	These documents request specific information from the tenderers concerning the works. For example, tenderers are generally required to provide an overall cost, a breakdown of this cost, a program, details of key personnel, plant and equipment, subcontractors to be used and methodologies. The tender form is a formal statement of the tenderer's offer to supply services in accordance with the tender documents. A useful example of a tender form can be found in Australian Standard AS 2125 - 1992.
Conditions of contract	This document contains the general conditions of contract which sets out the contractual basis for carrying out the works. In addition, special conditions are sometimes included which are unique to the lot feeder and/or project.
Specification	Depending on the type of delivery method chosen, this document may be a project brief or a detailed technical specification of the works. These documents set out the performance and technical criteria for the project. See <i>Section 46 - Design drawings and technical specifications</i> .
Drawings	The number and standard of drawings provided is dependent on the chosen method. See <i>Section 46 - Design drawings and technical specifications</i> .
Additional information	Additional information concerning the project may include Development Approval Conditions, Environmental Impact Study (EIS) reports and other documents relevant to the development of the project.

A non-refundable charge may in some instances discourage the collection of documents by parties who have no interest in submitting a tender.

Lot feeders should consider the following issues relating to refundable tender deposits

- administrative costs of issuing receipts and securing the money
- financial accountability
- damaged documents or alterations to tender documents that make them unsuitable for use in construction or contract management at a later date.

Tender timeframes

The timeframe for tender preparation by the contractor and evaluation by the lot feeder will vary depending on factors such as project size, complexity or external pressures. The lot feeder should ensure that the time allowed for tenderers to prepare tenders and for the lot feeder to evaluate and select tenders is reasonable. Due regard should be given to the costs of tendering.

When preparing tenders, tenderers need time to request prices from their subcontractors and suppliers and to review all the detailed tender documents and specifications. Contractors who are keen to win the project will usually take longer than contractors who are not. As a guide allow four weeks minimum. A longer period would be appropriate for complex or large contracts and for tenders requiring a pre-tender meeting.

Criteria for selection

Before calling tenders, the lot feeder (or consultant) must establish project-specific qualification criteria and decide the relative importance of each. Such criteria need to cover the critical factors on which the success of the project is based. The qualification criteria must be clearly stated in the tender documentation and their order of importance may be indicated e.g. with a simple list. The actual weighting of the criteria need not be disclosed.

Typical criteria for selection include

- **Conformity** – does the tender conform to the requirements outlined in the tender documents?
- **Capability** – this would include previous experience, financial resources, technical resources, quality assurance system, workplace health and safety record, environmental compliance
- **Innovation**
- **Price** – the tendered cost may include whole-of-life as well as capital costs
- **Construction period**

Call for tenders

In the case of open or public tenders called by public advertisement, advertisements must be placed in appropriate newspapers, publications or electronic media at appropriate times so as to attract suitable applicants.

In cases where tenders are advertised, it is recommended that the advertisement includes the following

- an appropriate summary description of the work required
- details of when and where the documents may be obtained
- details of when and where tenders will close
- details of any tender documentation purchase price or deposit and if applicable, the method of obtaining a refund of that cost
- The name, address, telephone number, facsimile number and email address of the lot feeder's contact person.

With respect to procedural issues, it is recommended that the lot feeder ensures that

- A written record is kept of all persons to whom the tender documents are issued. It is also recommended that each tender set be numbered for identification and tracking purposes.
- Tender document deposit monies collected and receipts issued (if required).
- In the case of selected, pre-qualified and invited tenders, the tenderers are informed of the number of tenders being invited.
- No tender price offered orally is received.

Responding to invitations to tender and developing the commercial offer

In the case of selected or invited tenders, where a tenderer decides not to proceed with the tender, the tenderer should promptly advise the lot feeder. In the case of pre-qualified tenders, tenderers should be required to provide an undertaking to tender if selected.

Tenderers should formally acknowledge the receipt of tender documents in writing and promptly advise the lot feeder if they become aware of errors, omissions, ambiguities or discrepancies in the documents.

The tenders submitted should conform to all aspects of the requirements defined in the tender documents.

Tender meetings and enquiries

It is recommended that all information provided between the parties is treated as confidential and commercial-in-confidence. The lot feeder should ensure that

- All briefing meetings held for tenderers are minuted. Minutes are then forwarded to all tenderers and are included as part of the tender documentation.
- The lot feeder contact person responsible for dealing with enquiries from tenderers is to document all such inquiries, noting the time, the date and the issue discussed.
- Information provided to one tenderer is also promptly given to all other tenderers.
- In the case where an enquiry reveals a significant error, omission, ambiguity or discrepancy in the tender documents, the information provided to resolve the issue is promptly forwarded in writing to all tenderers.

Amendments to tender documents

A structured review of the tender documents prior to issue will minimise the requirement to amend tender documents due to errors or omissions.

Where significant issues arise that make it necessary to amend the tender documents during the tender period, the amendments are advised as an addendum, forwarded to all tenderers. Each addendum is issued in sufficient time for all tenderers to consider the amendments properly and fully before tenders close. The tender period may need to be extended, particularly if the addendum is issued late in the tender period.

Each addendum contains a returnable covering sheet so that tenderers can acknowledge its receipt in writing. A statement of confirmation that allowance has been made for each addendum is required in the submission of the tenders.

The lot feeder should ensure that each tenderer acknowledges receipt of each addendum in writing and confirms in their tenders that allowance has been made for each addendum.

Submission and closing of tenders

It is recommended that the lot feeder ensures that

- The security and confidentiality of all tenders received is achieved following the closing of tenders. Procedures for the security of documents, access to documents and the availability of price-sensitive information are to be developed in advance of the closing of tenders.
- Tenders are generally received in a secure tender box and opened in the presence of a specially qualified team (not less than two people).
- One copy of each of the tenders (the original) is separately stored in a secure location from working copies, for reference purposes.
- Typically, the timing of the closing of tenders is
 - not earlier than 2.00 pm.
 - not on a Monday or day following a public holiday.
- Each tenderer is informed in writing that its tender has been received.
- In the event that the lot feeder is prepared to consider late tenders and non-conforming offers, the conditions in the tender documentation should describe how the lot feeder will treat late tenders and non-conforming or alternative offers.

Opening and recording tenders

Tenders should be opened and recorded in a way that maintains the security of the tenderer's intellectual property and that offers no advantage to one tenderer over another. It is good practice to open and summarise tenders as soon as possible after the closing time. The tenders should be opened, checked and recorded by at least two people.

Non-conforming tenders

Tenders which fully comply with tender requirements should be given preference. The lot feeder may consider non-conforming tenders where the tenderer can demonstrate that

- their bid will be more cost effective without jeopardising the desired outcomes and levels of service; and
- the rights and interests of both parties are protected; or
- superior levels of service can be achieved whilst conforming with (a) and (b) above; or
- new cost effective technologies, procedures or techniques are offered which can meet the requirements of (a) and (b) above.

Tenderers who seek to reduce costs by compromising workplace health and safety, service or other factors which would reduce the rights or interest of the lot feeder should be deemed non-conforming and be excluded.

Tender analysis

The importance of assembling an experienced and competent tender evaluation team is critical to the success of the tender process.

Above all, a consistent approach to the evaluation of all tenders is required.

After receipt of tenders, submissions are comparatively assessed against the Criteria for Selection defined in the tender documents. Tenders are likely to contain significant differences, particularly in areas of design, time, cost, risk allocation, durability and operation. Tenders may also differ in terms of certainty of delivery and clarity of content.

A tender that does not comply with the tender documents should be rejected. If a tender is rejected, the reasons for such action are to be clearly documented and communicated to the tenderer.

Tender clarifications

The evaluation team may seek clarification of any issues from applicants, verbally or in writing, but may not solicit new information. The tender clarifications need to be carefully managed to ensure that confidentiality is maintained and tenderers are treated equitably and ethically.

Tender selection and award

The lot feeder should ensure that unsuccessful tenderers are advised in writing that their tenders have been unsuccessful.

In the finalisation of the contract documentation, the lot feeder and successful tenderer shall ensure that the contract incorporates the tender submission of the successful tenderer and any qualifications during the tender process. It is noted that this phase of the process is to settle all outstanding technical, commercial and/or legal issues necessary for finalisation of the contract. It is not an opportunity for either party to vary the final contract price or to materially alter the proposal.

Quick tips

- The tendering process ultimately determines who will undertake the construction works and the process by which a fair price and best value for undertaking the works is obtained.
- Prepare a project brief that clearly defines the scope of the project for which tender documents are to be prepared.
- Select a suitable process for selection of tenderers depending on the nature of the project.
- Prepare adequate tender documentation containing evaluation criteria, evaluation procedures and the proposed timing of the evaluation process.
- Clarify any issues in tenders with the tenderer.
- Allow sufficient time for the tenderer to make a tender submission and the lot feeder to fully assess the tenders received.
- Advise all unsuccessful tenderers in writing.
- Prepare a legally binding contract with the successful tenderer.

Further reading

Standards Australia, 1994, AS4120-1994 Code of tendering, Standards Australia, Canberra, ACT.

Standards Australia, 1997, AS 4000-1997 General conditions of contract, Standards Australia, Canberra, ACT.

Standards Australia, 1995, AS 4300-1995 General conditions of contract for design and construct, Standards Australia, Canberra, ACT.



FEEDLOT DESIGN AND CONSTRUCTION

48. Project management

AUTHORS: Rod Davis and Ross Stafford

Introduction

The function of project management is a relatively recent development as a specialist role in its own right. Consulting engineers have traditionally undertaken the project management function as part of their professional service to lot feeders. Lot feeders also have traditionally undertaken many of the brief development, communication and management activities now undertaken by a project manager.

In general terms, project management means the process of managing a construction project through all the stages (i.e. from the initial concept to the final completion including, overall planning, coordination, the appointment of consultants, deciding on project delivery method, preparation of design and specifications, tendering and the construction work and project close-out). This may be done in a variety of ways as outlined in *Section 45 – Feedlot construction delivery*.

The project management delivery method is aimed at meeting a lot feeder's requirement to produce a functionally and financially viable project. The functions performed by a project manager typically include the design, or procurement of the design on behalf of the lot feeder; the construction or procurement of the construction on behalf of the lot feeder; and, in particular instances, other activities including site selection, site acquisition, permit approvals, advertising of the project, project administration and/or other activities which might otherwise need to be performed by the lot feeder.

The essential feature of project management is that services offered are management services rather than the construction works. However, the on-site construction works will also need to be managed – usually by the construction contractor. Typically, the services provided by the construction contractor are restricted to construction activities rather than design activities or site acquisition, but they also include engaging subcontractors on behalf of the lot feeder.

Project management objectives

The objectives of project management are to

- undertake the necessary activities to support successful project delivery
- implement various operations through proper coordination and control of planning, design, estimating, contracting and construction of the entire process.

Mandatory requirements

Compliance with

- relevant Commonwealth, state and local authority codes, regulations and relevant Australian standards as applicable to conditions of contract, tendering, project and risk management.
- legal obligations to provide for the health and safety of workers within work health and safety regulations and legislation (Work Health and Safety Act 2011/Work Health and Safety Regulations 2011).
- licences, consent, permits, approvals and requirements of organisations having jurisdiction over the construction work.

Possible solutions

On large or complex construction projects, an independent project manager can be an advantage, particularly where non-standard delivery methods such as construction management are employed, to ensure the lot feeder's interests are maintained. Alternatively, the lot feeder may wish to manage the project but must be aware of the risks and obligations of this role.

The following describes the project management activities necessary in most reasonably sized construction projects. The decision as to who undertakes these activities, the need for a specialist project manager and the particular activities assigned to them are decisions to be made for each project.

Scope

The scope of the project must be clearly defined. The typical services that the project manager can provide include

- overseeing the development of the project brief, ensuring it covers the purpose of the project
- ensuring that all relevant stakeholders have provided appropriate input into the development of the project brief
- ensuring that the stakeholder/s sign off on the project brief
- ensuring that all works required to complete the project are listed, with a clear understanding of who undertakes the work, including any items to be procured by the lot feeder
- collation of project requirements including the brief, budget, time frames and standards for the project team
- identifying any constraints or conditions that will impact on the project delivery.

Procurement

The typical services the project manager provides include

- Selection, in consultation with lot feeder, of the appropriate project delivery method (e.g. traditional lump sum, design/construct)
- Management of the selection of engineering and other consultants as required
- Ensuring that all required disciplines and specialist advisers are included in the project team
- Ensuring that the appropriate contracts are executed between lot feeder and consultants
- Processing the contract progress payments to the construction contractor and/or consultants
- Advising on requirements and timing of materials and services to be provided by the lot feeder or other parties, and ensuring that they are built into project programs
- Ensuring that feasibility study reports, preliminary drawings and design drawings are completed, coordinated, checked and signed off at appropriate times
- Management of the tender call, tender recommendation and contractor engagement process; ensuring that contract documents are prepared and signed

- Coordination and management of the various contractors and suppliers so the work proceeds in a timely and efficient manner where all contractors are given access to the site when reasonably required
- Advising on-site inspection requirements from consultants and ensuring appropriate site meetings and inspections are undertaken, and that appropriate instructions are given to the construction contractor
- Ensuring that variations and contract instructions are made on a timely basis
- Management of project completion and handover process
- Management of dispute resolution, contract defaults and liquidations.

Cost

Project costs must be managed. The typical services that the project manager provides include

- Reviewing and managing of project budget and cost estimates
- Ensuring that cost issues are flagged early and discussed with all stakeholders
- Management of variations and extension of time expenditure
- Processing contract payments to contractors
- Managing strategies to maintain the project budget when cost pressures arise.

Contract management and administration

A construction project, irrespective of the delivery method, requires good contract administration to manage formation of contracts, contractual agreements, cost control, payments and variations, final accounts, commissioning, handover, defects rectification, claims and disputes and final financial close of the project. Poor management in any of these aspects leads to unnecessary claims and disputes and eventually higher construction costs.

The purpose of contract management and administration is to

- Manage the delivery of a capital project and associated work in accordance with the executed contract documents
- Ensure the construction contractor fulfils their responsibilities, duties and outcomes in accordance with documented requirements, the contract itself, and statutory requirements
- Ensure that the construction contractor is properly and promptly paid for works suitably carried out
- Ensure that subcontractors to the construction contractor are paid properly and promptly for works suitably carried out
- Avoid and resolve construction disputes
- Ensure that defects are suitably rectified
- Ensure that the correct procedures are followed for variations or a change in orders
- Ensure that charges for non-contracted construction services are authorised and promptly paid.

Contract administration is a specialised skill, and it is common practice for a lot feeder to appoint or delegate the responsibility for contract administration to a person who is then the lot feeder's representative.

All parties should be aware of their technical, legal and financial obligations and responsibilities as failure to do so may involve disruptive and costly compensation claims.

Quality control

Quality control is essential to provide and deliver an agreeable project outcome. Typically, the construction contractor is responsible for checking each subcontractor's conformance to design drawings, design documents, material specifications and/or erection/installation requirements.

Should non-conformances be found, the construction manager must notify the subcontractor(s) involved that corrective work is required and follow up until all work is completed satisfactorily. However, a project manager may be allocated this role.

Basic concepts of quality control from a project manager's perspective are

- Ensuring that the lot feeder's quality standards are articulated and understood by consultants
- Managing the quality standards required from consultants and contractors.

Risk

The lot feeder and project manager should identify all project risks and prepare plans to minimise them.

Schedule

A clearly defined project schedule is critical to the success of a construction project. This includes a clear recognition of the tasks of work, the proper order of their appearance on the job, correct duration of work, complete resources allocation to tasks and a clear purchasing and delivery register. Key project management activities comprise

- Planning and establishing the project program and identifying key strategic activities
- Monitoring and updating the program as required, flagging the timely provision of materials and services from other parties
- Management of the project team
- Advising on strategies to maintain the project program when delays are evident.

Communication

A key ingredient in all successful construction projects is clear, efficient and effective communication between all participants. Good communication does not automatically occur on construction projects but must be nurtured from project inception through handover. The lot feeder, construction contractor and consultants must set the stage for effective project communication during initial contract negotiations and teamwork discussions.

Basic concepts of coordination and cooperation, as summarised below, can foster continuing effective communication throughout the project.

- Establishing and managing the consultative mechanisms including project meeting regimes and reporting processes.
- Establishing and managing the approval mechanisms for various signoff requirements and identifying those with appropriate authority.
- Advising on and managing government and statutory approvals.
- Convening reporting meetings with stakeholders as appropriate.
- Preparation of regular progress reports on project issues, including costs relative to budget and progress relative to program.
- Ensuring that all team members understand their roles and responsibilities and ensuring their ongoing commitment to the project.

Workplace health and safety

Health and safety of all participants in the project is a crucial area to manage. Building and construction activities by their inherent nature are high risk. The construction contractor, subcontractors and their workers face risks from hazards that must be managed to prevent injuries, illness and deaths.

Various state and Commonwealth regulations outline how workplace health and safety risks from certain hazards must be managed, and the responsibilities and duties for managing health and safety on the project site. Typically, the regulations cover

- entity responsible for workplace health and safety
- construction safety plans
- work method statements for high risk construction activities
- general and site-specific induction of personnel
- housekeeping practices
- safety of plant provided for common use
- excavations (including trenches)
- working at heights (including work on roofs, from ladders and trestle ladder platforms and work to erect or dismantle scaffolding)
- protecting the public and workers from falling objects
- amenities.

It is mandatory to have policies and procedures in place for a construction project to minimise the risk of death, injury or illness for those people working on or visiting the site.

Practical completion and handover

The handover of a project to the lot feeder at the end of construction is a very important stage of the project management process and key to the operational success of the project.

The contract will define the stage at which the project is at practical completion and handover is to occur. A well organised, efficient and effective transfer of information from project works to the lot feeder is essential at this stage.

The handover of a project usually involves the issue of a Certificate of Practical Completion. Typically, the Certificate of Practical Completion should not be issued, and the project should not be handed over, until the following activities (if contracted) have been undertaken or fulfilled.

- Connection and commissioning of all plant and equipment, systems and all testing data and reports made available, and the operation and maintenance manuals supplied.
- Licences, certifications and registrations required by relevant workplace standards, building acts or any other legislation provided.
- Defect liability period (DLP) maintenance management processes put in place and confirmed by the lot feeder.
- Training sessions successfully held to the satisfaction of operational managers in each field of expertise.
- As-constructed or as-removed information has been supplied. As-constructed information is required to allow a smooth transition from project to actual use or occupation. As-constructed information includes schedules of equipment, technical data and manufacturer's technical literature including operation and performance information on individual plant and equipment, copies of certifications and warranties, all test results, maintenance schedules and complete as-built drawings in digital (ACAD) format and list of suppliers.

Once the Certificate of Practical Completion has been accepted, the post construction phase commences. It is not uncommon for construction projects to remain active for several months while equipment continues to be purchased or work is accomplished under other contracts to complete the work on the project.

Post construction

The lot feeder, project manager and/or construction contractor monitor the project during the defects liability period. The project manager or lot feeder is responsible for managing construction contractor callbacks following contract completion. As defects in the work are discovered, the construction contractor is notified. The project manager investigates the issue, notifies the contractor if corrective action is required and works with the lot feeder and construction contractor to coordinate access and scheduling for the work.

As the defects liability period nears completion, the project manager confirms that all the defects work requests have been completed. Typically, a post occupancy inspection is held with the lot feeder, project manager and construction contractor prior to the end of the defects liability period.

As-constructed information is supplied and held as reference for future development. Final completion occurs when all required as-constructed documentation is provided, defects work completed and all payments made to the construction contractor.

Quick tips

- Every construction project requires a process of managing all its stages. Project management is sometimes overlooked or put low on the priority list when setting up a project.
- The lot feeder may wish to project manage the project. However, the lot feeder must be aware of the risks and obligations of this role.
- On large or complex construction projects, an independent project manager can be an advantage.
- Contract administration is a key element of project management that needs to be performed either by the lot feeder or the project manager.
- Safety must be the one constant that is built in all planning, design, bidding, and implementation of each project.

Further reading

Standards Australia, 2002, AS 4915-2002 Project Management – General Conditions, Standards Australia, Canberra, ACT.

Standards Australia, 2002, AS 4916-2002 Construction Management – General Conditions, Standards Australia, Canberra, ACT.